

**Ersatzteilliste  
Spare Parts List  
Liste des pièces de rechange**

# **KSM 900 B**

**1.896-101.0 KSM 900 B**

GRUPPE: 1.0 VERKLEIDUNG  
GROUP: 1.0 COVER  
GRUPPE: 1.0 CARROSSAGE

**A1**

**KSM 900 B**

**GRUPPE: 1.0 VERKLEIDUNG**  
**GROUP: 1.0 COVER**  
**GRUPPE: 1.0 CARROSSAGE**

GRUPPE: 1.0 VERKLEIDUNG  
GROUP: 1.0 COVER  
GRUPPE: 1.0 CARROSSAGE

# B1

# KSM 900 B

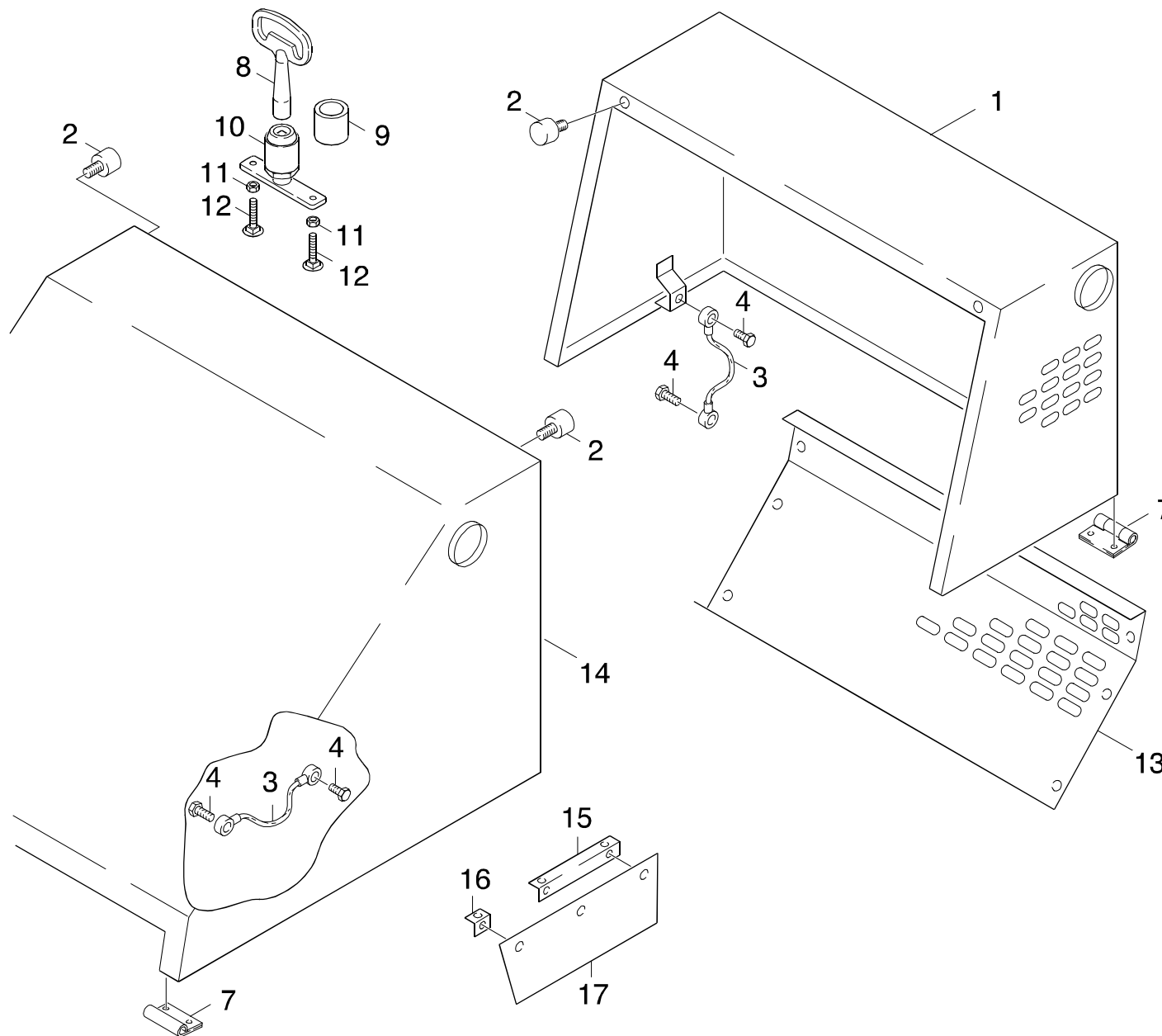

Symbolbeschreibung siehe M16 / symbol description see M16 / désignation de système voir M16 /

GRUPPE: 1.0 VERKLEIDUNG  
GROUP: 1.0 COVER  
GROUPE: 1.0 CARROSSAGE

C1

KSM 900 B

POS. ITM. POS.	BENNENNUNG DESCRIPTION DESIGNATION	TEILE-NR. PART-NO. NO.PIECE	STCK QTY. NBR.
1	HAUBE HINTEN / COVER / CAPOT	6.952-001.0	1
2	ANSCHLAGPUFFER / AXLE BUFFER / TAMPON	6.437-373.0	4
3	SEIL / ROPE / CABLE	6.431-072.0	4
4	6KT-SCHR. M 6X 25 / HEXAGONAL HEAD SCREW / VIS HEXAGONAL	7.304-386.0	8
7	SCHARNIER / HINGE / CHARNIERE	6.372-056.0	4
8	SCHLUESSEL / KEY / CLE	6.815-133.0	1
9	BUCHSE / BUSH / DOUILLE	6.347-075.0	1
10	VORREIBER / SASH FASTENER / TOURNIQUET	6.375-186.0	1
11	6KT-MUTTER M 6 / HEXAGON NUT / ECROU HEXAGONAL	7.311-003.0	2
12	FL.RD.SCHR. M 6X 25 / SAUCER-HEAD SCREW / BOULON A TETE BOMBEE	7.303-183.0	2
13	ABDECKBLECH / COVER PLATE / TOLE DE PROTECTION	6.952-002.0	1
14	HAUBE VORNE / COVER / CAPOT	6.952-003.0	1
15	KLEMMLEISTE / STRIP TERMINAL / BORNE PLATE	6.952-004.0	1
16	KLEMMSTUECK / CLAMP / PLAQUE DE SERRAGE	6.952-005.0	1
17	GUMMISCHUERZE / RUBBER APRON / TABLIER CAOUTCHOUC	6.370-088.0	1

"=> xxxxxx" = bis Werknummer / up to serial No. / jusqu' au No. de fabr. / "xxxxxx =>" = ab Werknummer / from serial No. / a partir du No. de fabr. /

GRUPPE: 2.0 FAHRGESTELL /SB/LR  
GROUP: 2.0 CHASSIS  
GRUPPE: 2.0 CHASSIS

**A2**

**KSM 900 B**

**GRUPPE: 2.0 FAHRGESTELL /SB/LR**  
**GROUP: 2.0 CHASSIS**  
**GRUPPE: 2.0 CHASSIS**

Ersatzteile unter [www.gluesing.net](http://www.gluesing.net)

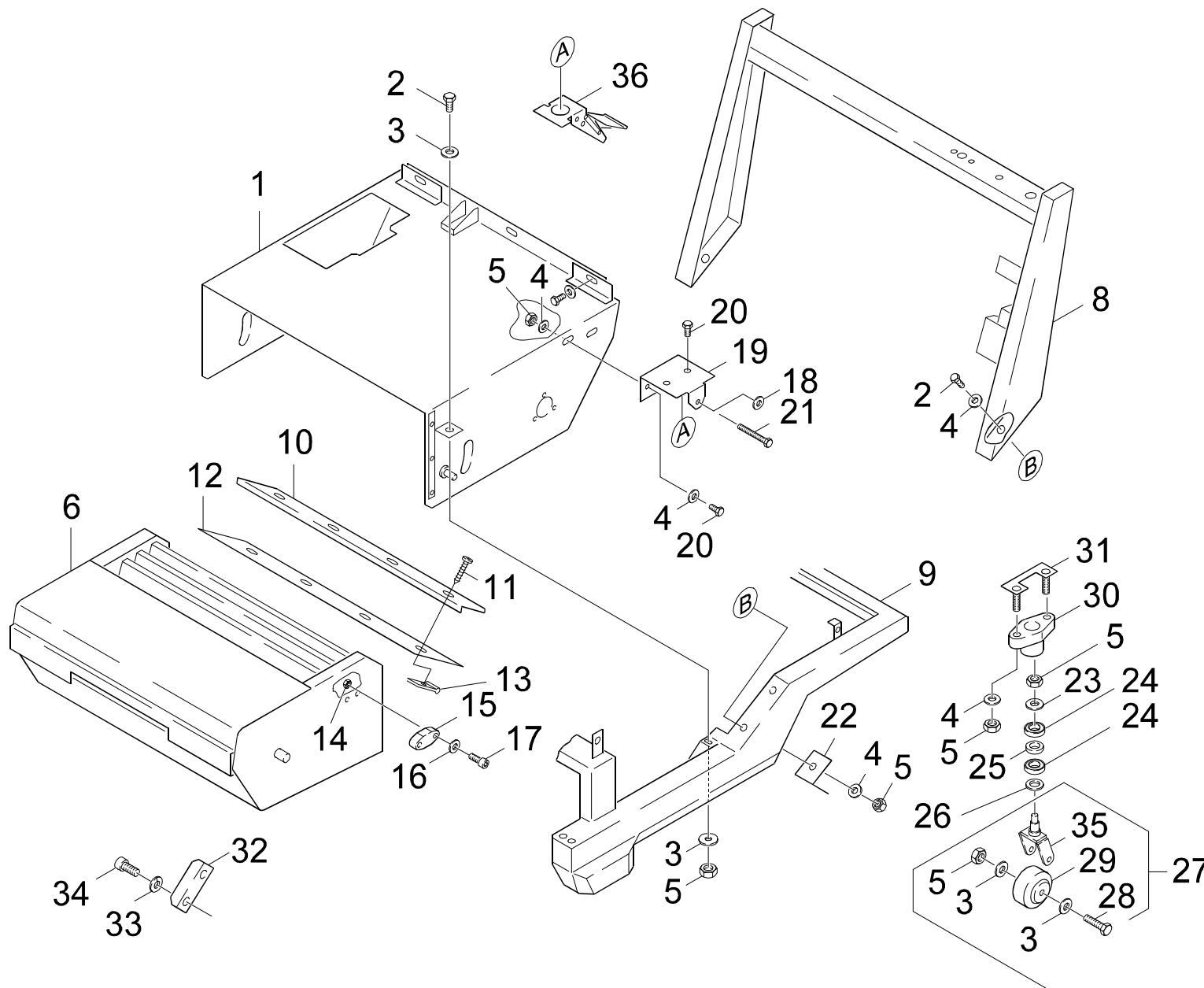

Symbolbeschreibung siehe M16 / symbol description see M16 / désignation de système voir M16 /

GRUPPE: 2.0 FAHRGESTELL /SB/LR  
GROUP: 2.0 CHASSIS  
GROUPE: 2.0 CHASSIS

C2

KSM 900 B

POS. ITM. POS.	BENNENNUNG DESCRIPTION DESIGNATION	TEILE-NR. PART-NO. NO.PIECE	STCK QTY. NBR.
1	MOTORPLATTE / MOTOR PLATE / PLAQUE (MOTEUR)	6.952-006.0	1
2	6KT-SCHR. M 8X 25 / HEXAGONAL HEAD SCREW / VIS HEXAGONAL	7.304-399.0	6
3	SCHEIBE 8 / WASHER / RONDELLE	7.312-289.0	6
4	SCHEIBE 8 / WASHER / RONDELLE	7.312-004.0	16
5	6KT-MUTTER M 8 / HEXAGON NUT / ECROU HEXAGONAL	7.311-427.0	18
6	SCHMUTZBEHAELTER / DIRT BOX / BAC A SAFETE	6.393-772.0	1
8	RAHMEN / FRAME / CADRE	6.952-007.0	1
9	FAHRGESTELL / CHASSIS / CHASSIS	6.952-008.0	1
10	KLEMMBLECH / PLATE / TOLE	6.952-013.0	1
11	BL.SCHR. ST4,8X19 / SHEET METAL SCREW / VIS A TOLE	7.303-078.0	5
12	DICHTLEISTE / SEALING STRIP / BAGUETTE D'ETANCHEITE	6.362-693.0	1
13	BLECHMUTTER B 4,8 / NUT / ECROU	6.310-022.0	5
14	6KT-MUTTER M 6 / HEXAGON NUT / ECROU HEXAGONAL	7.311-425.0	5
15	FUEHRUNGSSTUECK / GUIDE PART / PARTIE DE GUIDAGE	6.905-030.0	2
16	SCHEIBE 6 / WASHER / RONDELLE	7.312-003.0	4
17	SCHRAUBE M 6X 20 / SCREW / VIS	7.306-092.0	4
18	SCHEIBE / WASHER / RONDELLE	6.952-010.0	1
19	BUEGEL / STRAP / ETRIER	6.952-009.0	1
20	6KT-SCHR. M 8X 20 / HEXAGONAL HEAD SCREW / VIS HEXAGONAL	7.304-397.0	8
21	6KT-SCHR. M 8X 75 / HEXAGONAL HEAD SCREW / VIS HEXAGONAL	7.304-403.0	2
22	WINKEL / ANGLE / ANGLE	6.952-011.0	1
23	SCHEIBE / WASHER / RONDELLE	6.952-012.0	1
24	KUGELLAGER 6002-2RS / BALL BEARING / ROULEMENT A BILLE	7.401-115.0	4
25	RING / RING / BAGUE	6.346-032.0	2
26	S-RING 32X 1,2 / SPRING CLIP / CIRCLIP	7.343-231.0	2
27	LENKROLLE KPL. / CASTOR / ROUE PIVOTANTE	6.435-150.0	2
28	6KT-SCHR. M 8X 60 / HEXAGONAL HEAD SCREW / VIS HEXAGONAL	7.304-401.0	2
29	ROLLE / ROLLER / ROULETTE	6.952-014.0	2
30	FLANSCH / FLANGE / BRIDE	6.370-094.0	2
31	PLATTE KPL. / PLATE / PLAQUE	6.370-095.0	2
32	LEISTE / STRIP / BAGUETTE	6.370-087.0	2
33	FEDERRING 6 / SPRING WASHER / RONDELLE GROWER	7.313-050.0	4
34	SCHRAUBE M 6X 16 / SCREW / VIS	7.306-090.0	4
35	RADHALTER / WHEEL CARRIER / PORTE-ROUE	6.435-259.0	2
36	FESTSTELLBREMSE / PARKING BRAKE / FREIN D'ARRET	6.467-009.0	2

"=> xxxxxx" = bis Werknummer / up to serial No. / jusqu' au No. de fabr. / "xxxxxx =>" = ab Werknummer / from serial No. / a partir du No. de fabr. /

GRUPPE: 3.0 MOTOR  
GROUP: 3.0 MOTOR  
GRUPPE: 3.0 MOTEUR

**A3**

**KSM 900 B**

**GRUPPE: 3.0 MOTOR**  
**GROUP: 3.0 MOTOR**  
**GRUPPE: 3.0 MOTEUR**

Ersatzteile unter [www.gluesing.net](http://www.gluesing.net)



GRUPPE: 3.0 MOTOR  
GROUP: 3.0 MOTOR  
GRUPPE: 3.0 MOTEUR

B3

KSM 900 B

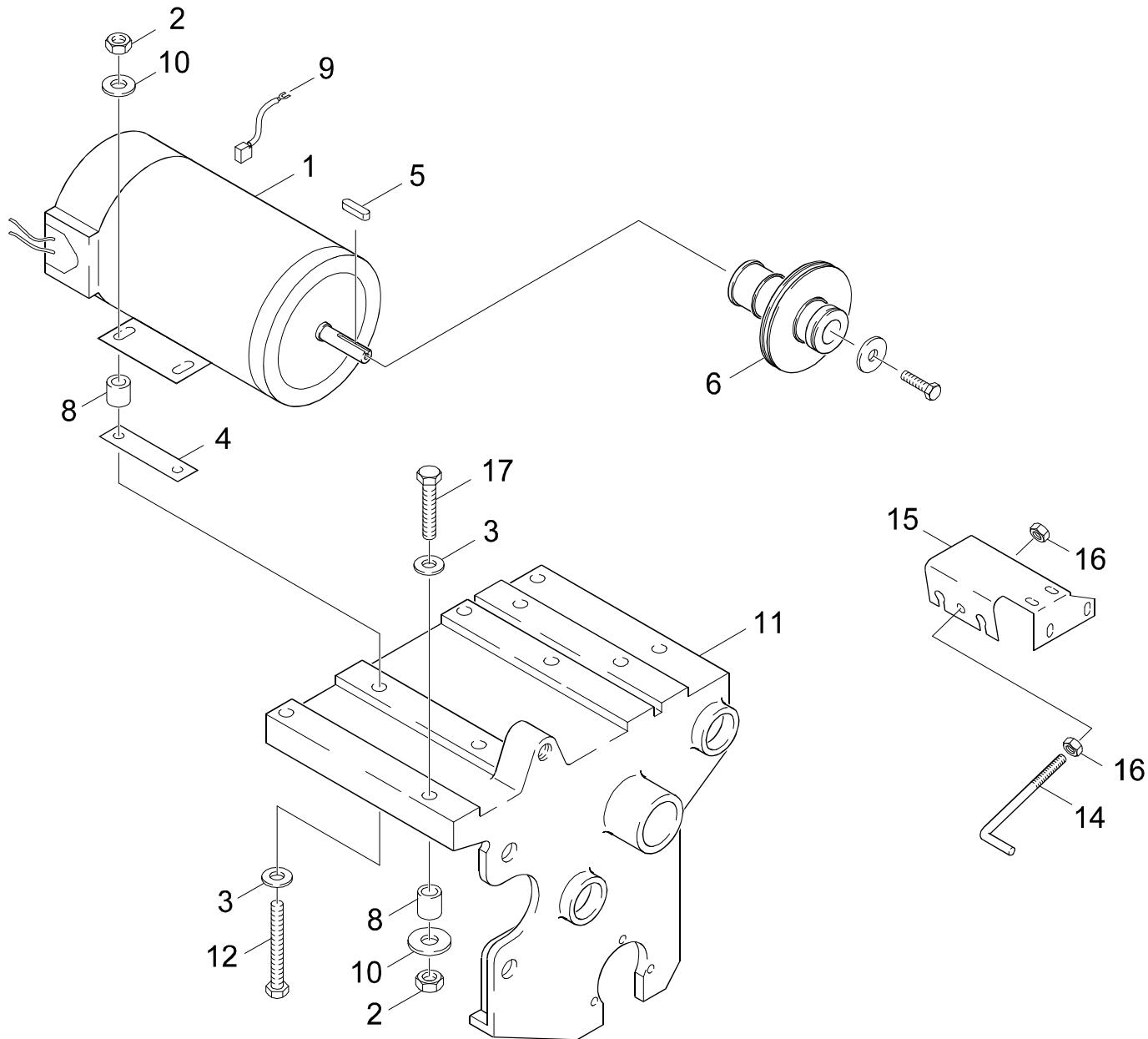

Symbolbeschreibung siehe M16 / symbol description see M16 / désignation de système voir M16 /

GRUPPE: 3.0 MOTOR  
GROUP: 3.0 MOTOR  
GROUPE: 3.0 MOTEUR

C3

KSM 900 B

POS. ITM. POS.	BENNENUNG DESCRIPTION DESIGNATION	TEILE-NR. PART-NO. NO.PIECE	STCK QTY. NBR.
1	E-MOTOR 0,75 KW / ELECTRIC MOTOR / MOTEUR ELECTRIQUE	6.611-494.0	1
2	6KT-MUTTER M 8 / HEXAGON NUT / ECROU HEXAGONAL	7.311-427.0	8
3	SCHEIBE 8 / WASHER / RONDELLE	7.312-004.0	8
4	PLATTE / PLATE / PLAQUE	6.952-112.0	2
5	PASSFEDER / SPRING / RESSORT D'ADJUSTAGE	6.952-113.0	1
6	RIEMENSCHLEIBE / PULLEY / POULIE	6.952-114.0	1
7	6KT-SCHR. M 8X 50 / HEXAGONAL HEAD SCREW / VIS HEXAGONAL	7.304-461.0	4
8	ABSTANDSHUELSE / DISTANCE SLEEVE / DOUILLE D'ECARTEMENT	6.952-111.0	4
9	KOHLEBUERSTE / CARBON BRUSH / CHARBON	6.905-031.0	4
10	SCHEIBE 8 / WASHER / RONDELLE	7.312-277.0	4
11	LAGERBOCK / BEARING BLOCK / SELLE D'APPUI	6.952-037.0	1
12	6KT-SCHR. M 8X 60 / HEXAGONAL HEAD SCREW / VIS HEXAGONAL	7.304-401.0	4
14	STANGE / BAR / TIGE	6.952-016.0	1
15	HALTER / BRACKET / FIXATION	6.952-110.0	1
16	6KT-MUTTER M 8 / HEXAGON NUT / ECROU HEXAGONAL	7.311-004.0	2

"=> xxxxxx" = bis Werknummer / up to serial No. / jusqu' au No. de fabr. / "xxxxxx =>" = ab Werknummer / from serial No. / a partir du No. de fabr. /

GRUPPE: 4.0 BEDIENUNGSELEMENT  
GROUP: 4.0 OPERATING ELEMENT  
GRUPPE: 4.0 ELEMENT D'EMPLOI

**A4**

**KSM 900 B**

**GRUPPE: 4.0 BEDIENUNGSELEMENT**  
**GROUP: 4.0 OPERATING ELEMENT**  
**GRUPPE: 4.0 ELEMENT D'EMPLOI**

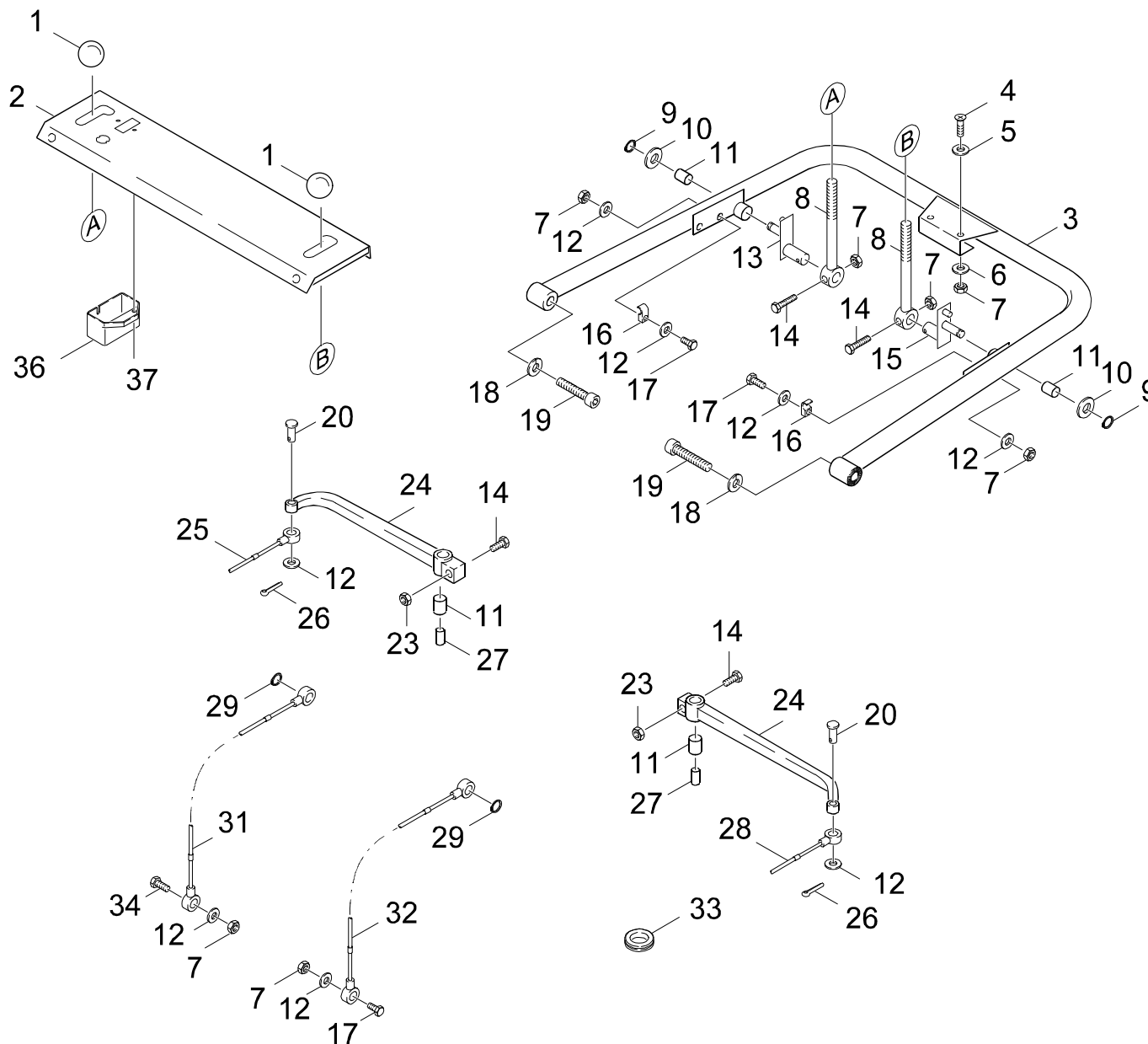

Symbolbeschreibung siehe M16 / symbol description see M16 / désignation de système voir M16 /

GRUPPE: 4.0 BEDIENUNGSELEMENT  
 GROUP: 4.0 OPERATING ELEMENT  
 GROUPE: 4.0 ELEMENT D'EMPLOI

C4

KSM 900 B

POS. ITM. POS.	BENNENUNG DESCRIPTION DESIGNATION	TEILE-NR. PART-NO. NO.PIECE	STCK QTY. NBR.
1	KUGELKNOPF M8 / BALL BUTTON / BOUTON SPHERIQUE	6.321-002.0	2
2	ARMATURENTAFEL / ARMATURE BOARD / PLAQUE	6.952-022.0	1
3	HOLM / BEAM / CHAPEAU COMPLET	6.952-023.0	1
4	SENKSCHR. M 6X 45 / FLAT HEADED SCREW / VIS A TETE CONIQUE	7.305-271.0	2
5	HOHLSCHEIBE / HOLLOW DISC / DISQUE (DOUBLE EN.)	6.952-025.0	15
6	SCHEIBE 6 / WASHER / RONDELLE	7.312-276.0	6
7	6KT-MUTTER M 6 / HEXAGON NUT / ECROU HEXAGONAL	7.311-425.0	8
8	HEBEL / LEVER / LEVIER	6.952-024.0	2
9	S-RING 12X1 / SPRING CLIP / CIRCLIP	7.343-003.0	2
10	PASSCHEI. 12X18X0,3 / WASHER / RONDELLE	7.343-222.0	12
11	DU-BUCHSE MB 1220 / BUSH / DOUILLE	6.952-026.0	4
12	SCHEIBE 6 / WASHER / RONDELLE	7.312-003.0	13
13	HEBEL-RECHTS / LEVER (RIGHT) / LEVIER (A GAUCHE)	6.952-028.0	1
14	6KT-SCHR. M 6X 35 / HEXAGONAL HEAD SCREW / VIS HEXAGONAL	7.304-388.0	4
15	HEBEL-LINKS / LEVER (LEFT) / LEVIER (A DROITE)	6.952-027.0	1
16	KABELSCHELLE / CABLE CLIP / COLLIER DE CABLE	6.647-089.0	2
17	6KT-SCHR. M 6X 25 / HEXAGONAL HEAD SCREW / VIS HEXAGONAL	7.304-386.0	3
18	FEDERRING 10 / SPRING WASHER / RONDELLE GROWER	7.313-052.0	2
19	ZYL.SCHR. M10X 40 / CHEESE HEAD SCREW / VIS A TETE CYLINDR.	7.306-065.0	2
20	BOLZEN B 6,0X 22 / BOLT / BOULON	7.316-221.0	2
23	6KT-MUTTER M 6 / HEXAGON NUT / ECROU HEXAGONAL	7.311-003.0	2
24	HEBEL / LEVER / LEVIER	6.952-029.0	2
25	BOWDENZUG / BOWDEN WIRE / CABLE SOUS GAINE	6.431-068.0	1
26	SPLINT 1,6X 10 / COTTER / GOUPILLE FENDUE	7.316-410.0	2
27	BUCHSE / BUSH / DOUILLE	6.952-030.0	2
28	BOWDENZUG / BOWDEN WIRE / CABLE SOUS GAINE	6.431-069.0	1
29	SICHERUNGSSCHEIBE / LOCK WASHER / RONDELLE D'ARRET	6.343-173.0	2
31	BOWDENZUG / BOWDEN WIRE / CABLE SOUS GAINE	6.431-070.0	1
32	BOWDENZUG / BOWDEN WIRE / CABLE SOUS GAINE	6.431-071.0	1
33	DURCHFUEHR.TUELLE / BUSH / DOUILLE DE TRAVERSEE	6.647-014.0	1
34	SCHRAUBE M 6X 20 / SCREW / VIS	7.306-092.0	1
36	KAPPE / CAP / CAPUCHON	6.387-764.0	1
37	CLIPMUTTER / CLIP NUT / ECROU (CLIP)	6.310-074.0	2

"=> xxxxxx" = bis Werknummer / up to serial No. / jusqu' au No. de fabr. / "xxxxxx =>" = ab Werknummer / from serial No. / a partir du No. de fabr. /

GRUPPE: 5.0 DIFFERENTIALACHSE  
GROUP: 5.0 DIFFERENTIAL AXLE  
GRUPPE: 5.0 ESSIEU DE DIFFERENTIEL

**A5**

**KSM 900 B**

**GRUPPE: 5.0 DIFFERENTIALACHSE**  
**GROUP: 5.0 DIFFERENTIAL AXLE**  
**GRUPPE: 5.0 ESSIEU DE DIFFERENTIEL**

GRUPPE: 5.0 DIFFERENTIALACHSE  
GROUP: 5.0 DIFFERENTIAL AXLE  
GRUPPE: 5.0 ESSIEU DE DIFFERENTIEL

B5

KSM 900 B

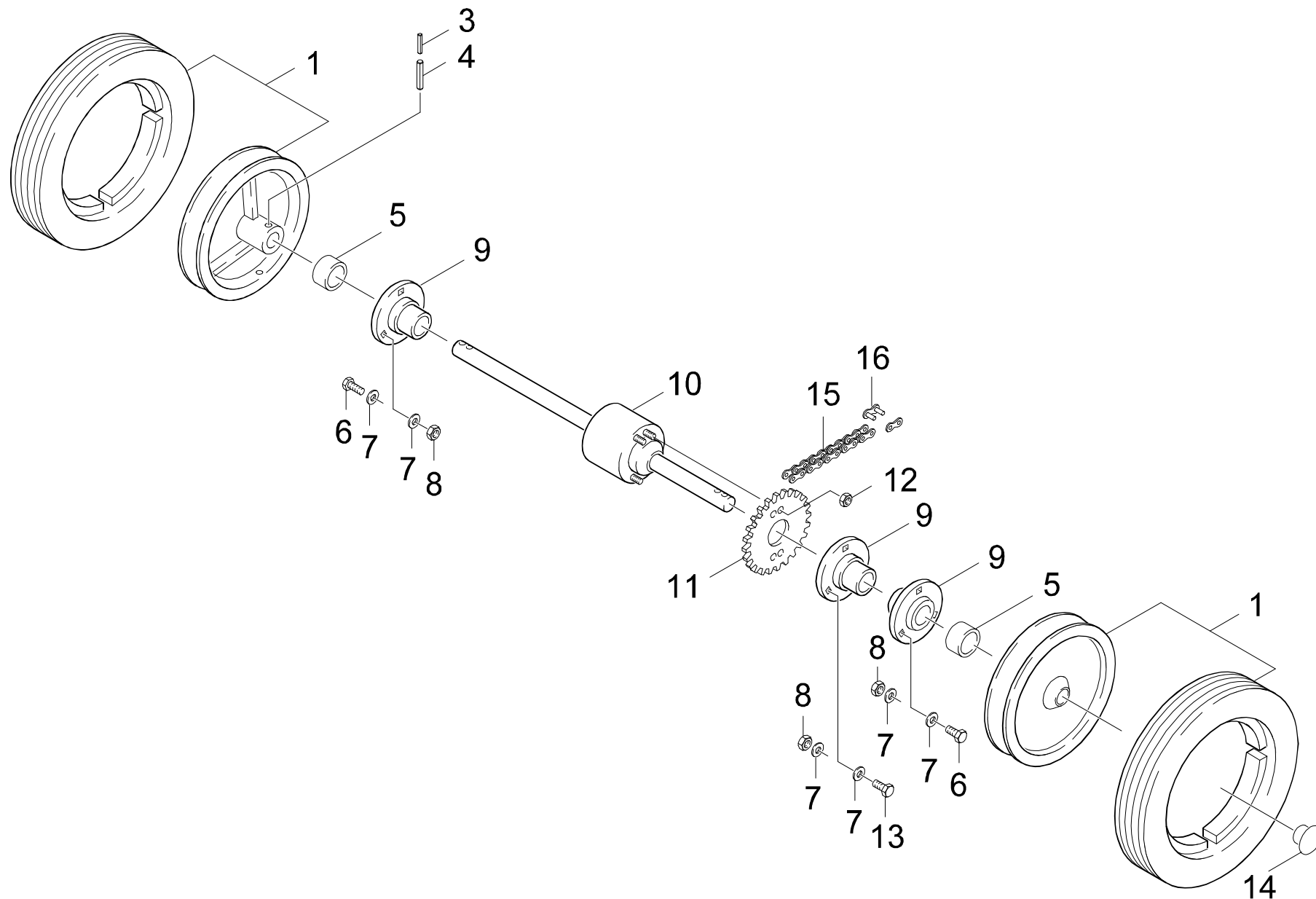

Symbolbeschreibung siehe M16 / symbol description see M16 / désignation de système voir M16 /

GRUPPE: 5.0 DIFFERENTIALACHSE  
GROUP: 5.0 DIFFERENTIAL AXLE  
GROUPE: 5.0 ESSIEU DE DIFFERENTIEL

C5

KSM 900 B

POS. ITM. POS.	BENNENNUNG DESCRIPTION DESIGNATION	TEILE-NR. PART-NO. NO.PIECE	STCK QTY. NBR.
1	RAD KPL. / WHEEL / ROUE	6.435-151.0	2
3	SPANNSTIFT 3,5X40 / PIN / GOUPILLE DE SERRAGE	7.314-938.0	2
4	SPANNSTIFT 6,0X40 / PIN / GOUPILLE DE SERRAGE	7.314-956.0	2
5	BUCHSE / BUSH / DOUILLE	6.347-038.0	2
6	6KT-SCHR. M 8X 25 / HEXAGONAL HEAD SCREW / VIS HEXAGONAL	7.304-399.0	6
7	SCHEIBE 8 / WASHER / RONDELLE	7.312-004.0	18
8	6KT-MUTTER M 8 / HEXAGON NUT / ECROU HEXAGONAL	7.311-427.0	9
9	FLANSLAGER / FLANGED BEARING / FLASQUE-BRIDE	6.401-213.0	3
10	DIFFERENTIALACHSE / DIFFERENTIAL AXLE / ESSIEU DE DIFFERENTIEL	6.952-031.0	1
11	KETTENRAD / CHAIN WHEEL / ROUE DENTEE	6.432-071.0	1
12	6KT-MUTTER 5/16"-18 / HEXAGON NUT / ECROU HEXAGONAL	6.310-075.0	4
13	6KT-SCHR. M 8X 30 / HEXAGONAL HEAD SCREW / VIS HEXAGONAL	7.304-400.0	3
14	VERSCHLUSSTOPFEN / DRAIN PLUG / BOUCHON	6.952-032.0	2
15	ROLLENKETTE / ROLLER CHAIN / CHAINE A ROULEAUX	6.432-051.0	1
16	GLIED E-06B-1 / CHAIN LINK / ELEMENT DE CHAINE	7.432-003.0	1

"=> xxxxxx" = bis Werknummer / up to serial No. / jusqu' au No. de fabr. / "xxxxxx =>" = ab Werknummer / from serial No. / a partir du No. de fabr. /



GRUPPE: 6.0 FAHRANTRIEB TEIL 1  
GROUP: 6.0 TRACTION MOTOR  
GRUPPE: 6.0 ENTRAINEMENT

**A6**

**KSM 900 B**

**GRUPPE: 6.0 FAHRANTRIEB TEIL 1**  
**GROUP: 6.0 TRACTION MOTOR**  
**GRUPPE: 6.0 ENTRAINEMENT**

GRUPPE: 6.0 FAHRANTRIEB TEIL 1  
GROUP: 6.0 TRACTION MOTOR  
GRUPPE: 6.0 ENTRAINEMENT

# B6

# KSM 900 B

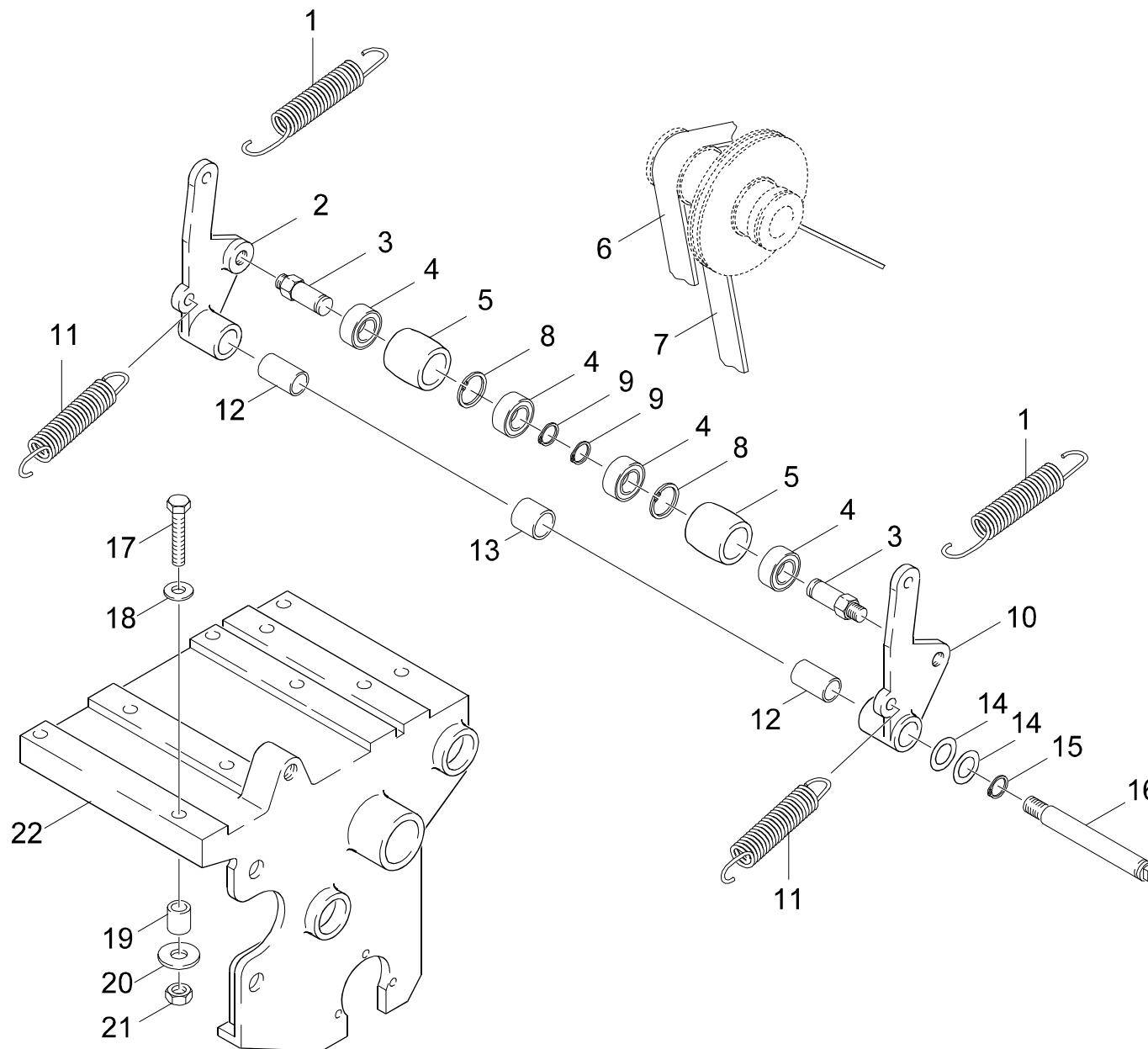

Symbolbeschreibung siehe M16 / symbol description see M16 / désignation de système voir M16 /

GRUPPE: 6.0 FAHRANTRIEB TEIL 1  
GROUP: 6.0 TRACTION MOTOR  
GROUPE: 6.0 ENTRAINEMENT

C6

KSM 900 B

POS. ITM. POS.	BENNENUNG DESCRIPTION DESIGNATION	TEILE-NR. PART-NO. NO.PIECE	STCK QTY. NBR.
1	ZUGFEDER / EXTENSION SPRING / RESSORT DE TRACTION	6.330-041.0	2
2	HEBEL-LINKS / LEVER (LEFT) / LEVIER (A DROITE)	6.952-033.0	1
3	WELLE / SHAFT / ARBRE	6.903-476.0	2
4	KUGELLAGER 6002-2RS / BALL BEARING / ROULEMENT A BILLE	7.401-115.0	4
5	ROLLE / ROLLER / ROULETTE	6.435-180.0	2
6	FLACHRIEMEN 810X20 / FLAT BELT / COURROIE PLATE	6.348-190.0	1
7	FLACHRIEMEN 590X20 / FLAT BELT / COURROIE PLATE	6.348-189.0	1
8	S-RING 32X 1,2 / SPRING CLIP / CIRCLIP	7.343-231.0	2
9	S-RING 15X1 / SPRING CLIP / CIRCLIP	7.343-004.0	2
10	HEBEL-RECHTS / LEVER (RIGHT) / LEVIER (A GAUCHE)	6.952-034.0	1
11	ZUGFEDER / EXTENSION SPRING / RESSORT DE TRACTION	6.330-042.0	2
12	DU-BUCHSE MB 2030 / BUSH / DOUILLE	6.952-035.0	2
13	BUCHSE / BUSH / DOUILLE	6.952-036.0	1
14	PASSCHEI. 20X28X0,5 / WASHER / RONDELLE	7.343-214.0	8
15	S-RING 20X1,2 / SPRING CLIP / CIRCLIP	7.343-007.0	1
16	BOLZEN / BOLT / BOULON	6.952-038.0	1
17	6KT-SCHR. M 8X 50 / HEXAGONAL HEAD SCREW / VIS HEXAGONAL	7.304-461.0	4
18	SCHEIBE 8 / WASHER / RONDELLE	7.312-004.0	4
19	ABSTANDSHUELSE / DISTANCE SLEEVE / DOUILLE D'ECARTEMENT	6.952-111.0	4
20	SCHEIBE 8 / WASHER / RONDELLE	7.312-277.0	4
21	6KT-MUTTER M 8 / HEXAGON NUT / ECROU HEXAGONAL	7.311-427.0	4
22	LAGERBOCK / BEARING BLOCK / SELLE D'APPUI	6.952-037.0	1

"=> xxxxxx" = bis Werknummer / up to serial No. / jusqu' au No. de fabr. / "xxxxxx =>" = ab Werknummer / from serial No. / a partir du No. de fabr. /

GRUPPE: 7.0 FAHRANTRIEB TEIL 2  
GROUP: 7.0 TRACTION MOTOR  
GRUPPE: 7.0 ENTRAINEMENT

**A7**

**KSM 900 B**

**GRUPPE: 7.0 FAHRANTRIEB TEIL 2**  
**GROUP: 7.0 TRACTION MOTOR**  
**GRUPPE: 7.0 ENTRAINEMENT**

GRUPPE: 7.0 FAHRANTRIEB TEIL 2  
GROUP: 7.0 TRACTION MOTOR  
GRUPPE: 7.0 ENTRAINEMENT

B7

KSM 900 B

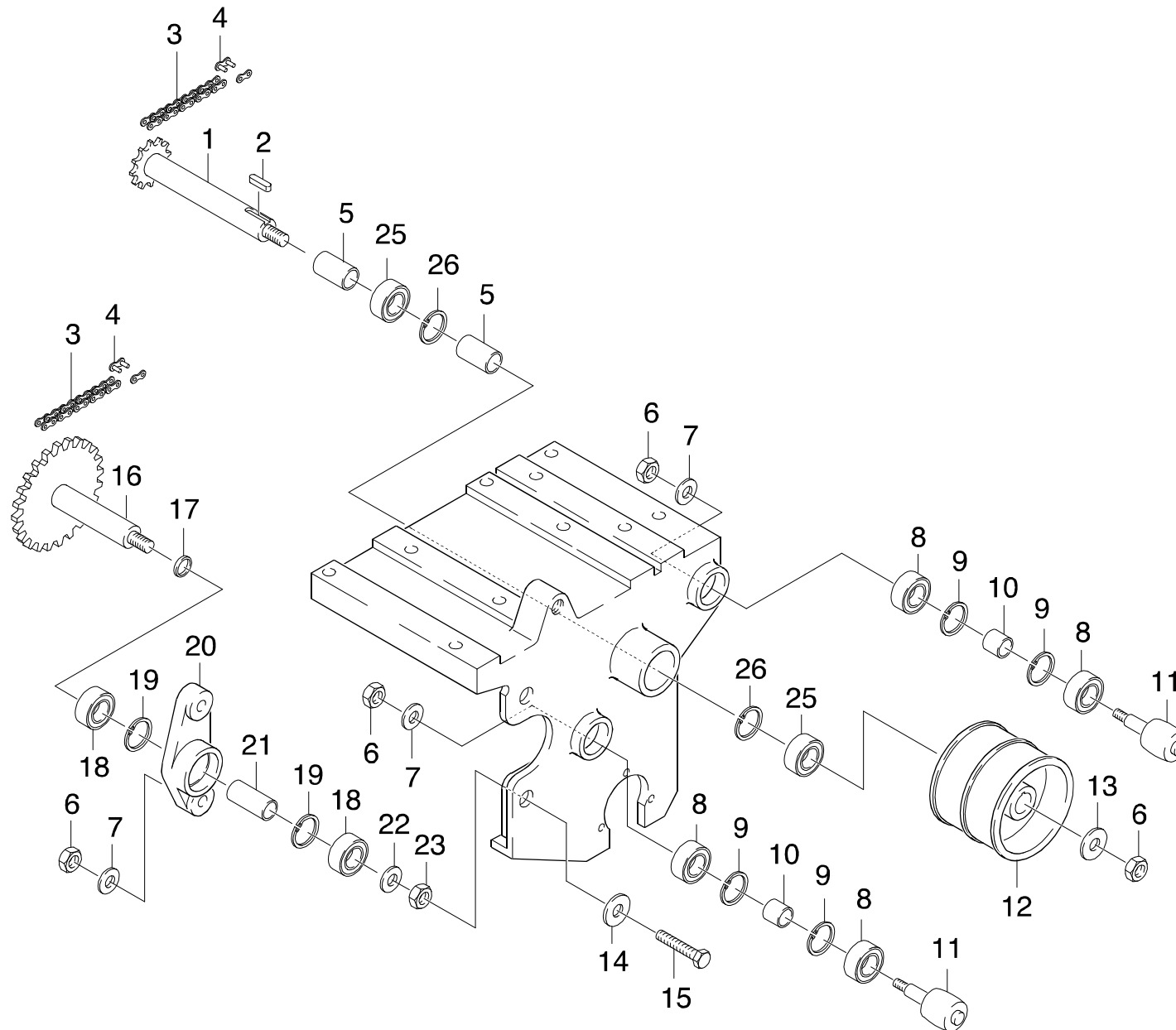

Symbolbeschreibung siehe M16 / symbol description see M16 / désignation de système voir M16 /

GRUPPE: 7.0 FAHRANTRIEB TEIL 2  
GROUP: 7.0 TRACTION MOTOR  
GRUPPE: 7.0 ENTRAINEMENT

C7

KSM 900 B

POS. ITM. POS.	BENNENUNG DESCRIPTION DESIGNATION	TEILE-NR. PART-NO. NO.PIECE	STCK QTY. NBR.
1	WELLE KPL. / SHAFT / ARBRE	6.903-477.0	1
2	PASSFEDER 6X 6X 25 / SPRING / RESSORT D'ADJUSTAGE	7.318-030.0	1
3	ROLLENKETTE / ROLLER CHAIN / CHAINE A ROULEAUX	6.432-051.0	2
4	GLIED E-06B-1 / CHAIN LINK / ELEMENT DE CHAINE	7.432-003.0	2
5	BUCHSE / BUSH / DOUILLE	6.952-039.0	2
6	6KT-MUTTER M10 / HEXAGON NUT / ECROU HEXAGONAL	7.311-423.0	5
7	SCHEIBE 10 / WASHER / RONDELLE	7.312-005.0	4
8	KUGELLAGER 6002-2RS / BALL BEARING / ROULEMENT A BILLE	7.401-115.0	4
9	S-RING 32X 1,2 / SPRING CLIP / CIRCLIP	7.343-231.0	4
10	BUCHSE / BUSH / DOUILLE	6.952-040.0	2
11	ROLLE / ROLLER / ROULETTE	6.952-041.0	2
12	RIEMENSCHLEIBE / PULLEY / POULIE	6.952-042.0	1
13	SCHEIBE 10 / WASHER / RONDELLE	7.312-285.0	1
14	SCHEIBE 11X38X 5 / WASHER / RONDELLE	6.312-045.0	2
15	6KT-SCHR. M10X 45 / HEXAGONAL HEAD SCREW / VIS HEXAGONAL	7.304-426.0	2
16	WELLE KPL. / SHAFT / ARBRE	6.903-478.0	1
17	DISTANZRING / SPACER RING / BAGUE D'ECARTEMENT	6.952-043.0	1
18	KUGELLAGER 6003-2RS / BALL BEARING / ROULEMENT A BILLE	7.401-105.0	2
19	S-RING 35X1,5 / SPRING CLIP / CIRCLIP	7.343-167.0	2
20	LAGERFLANSCH / FLANGE / BRIDE	6.952-044.0	1
21	BUCHSE / BUSH / DOUILLE	6.952-045.0	1
22	SCHEIBE 8 / WASHER / RONDELLE	7.312-277.0	1
23	6KT-MUTTER M 8 / HEXAGON NUT / ECROU HEXAGONAL	7.311-427.0	1
25	KUGELLAGER 6004-2RS / BALL BEARING / ROULEMENT A BILLE	7.401-133.0	2
26	S-RING 42X1,75 / SPRING CLIP / CIRCLIP	7.343-114.0	2

"=> xxxxxx" = bis Werknummer / up to serial No. / jusqu' au No. de fabr. / "xxxxxx =>" = ab Werknummer / from serial No. / a partir du No. de fabr. /

GRUPPE: 8.0 KEHRWALZE ANTRIEB-R  
GROUP: 8.0 REVERSING ROLLING MILL  
GRUPPE: 8.0 TAMBOUR

**A8**

**KSM 900 B**

**GRUPPE: 8.0 KEHRWALZE ANTRIEB-R**  
**GROUP: 8.0 REVERSING ROLLING MILL**  
**GRUPPE: 8.0 TAMBOUR**

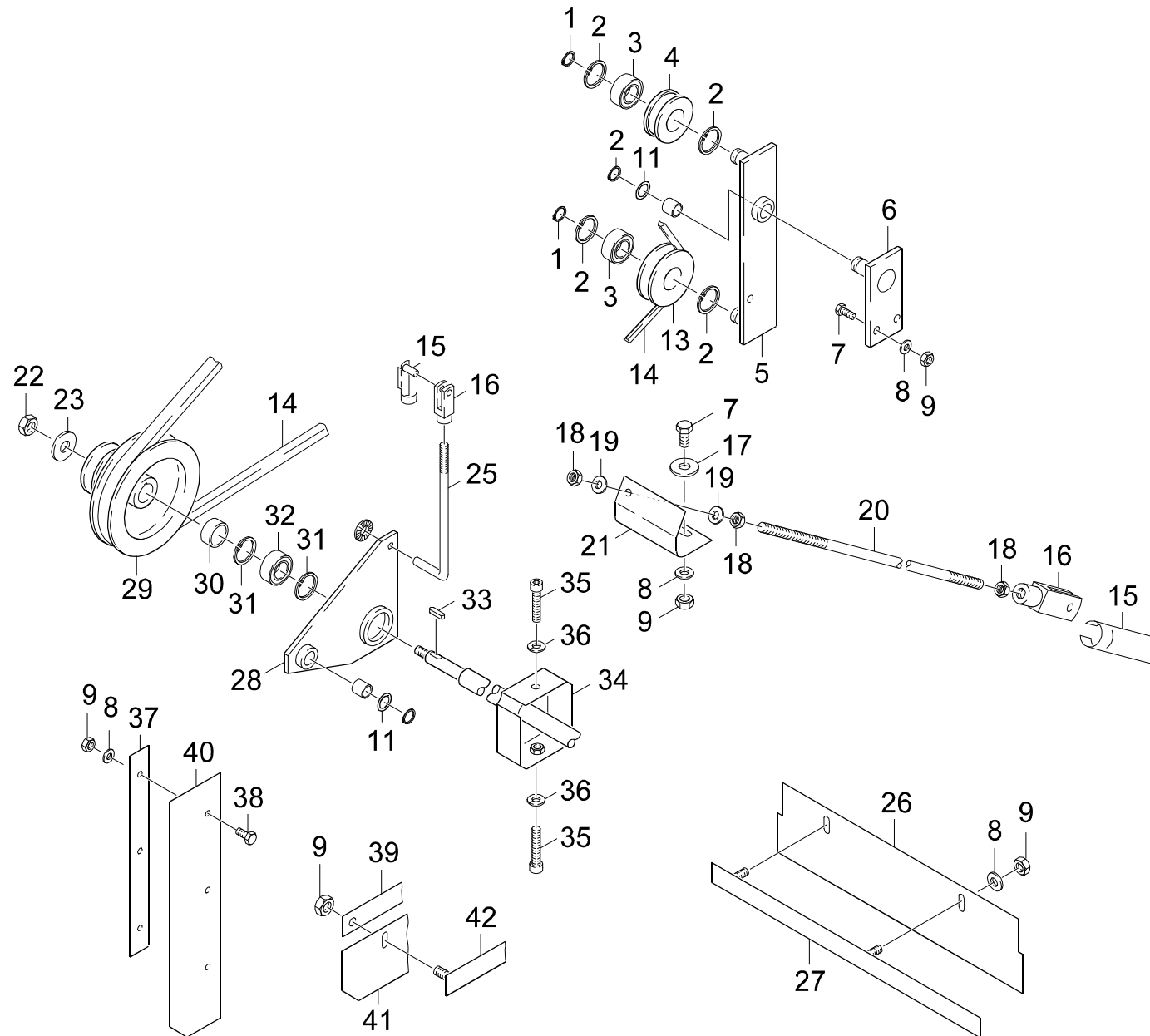

Symbolbeschreibung siehe M16 / symbol description see M16 / désignation de système voir M16 /



GRUPPE: 8.0 KEHRWALZE ANTRIEB-R  
 GROUP: 8.0 REVERSING ROLLING MILL  
 GROUPE: 8.0 TAMBOUR

C8

KSM 900 B

POS. ITM. POS.	BENNENNUNG DESCRIPTION DESIGNATION	TEILE-NR. PART-NO. NO.PIECE	STCK QTY. NBR.	POS. ITM. POS.	BENNENNUNG DESCRIPTION DESIGNATION	TEILE-NR. PART-NO. NO.PIECE	STCK QTY. NBR.
1	S-RING 12X1 / SPRING CLIP / CIRCLIP	7.343-003.0	2	38	6KT-SCHR. M 6X 25 / HEXAGONAL HEAD SCREW / VIS HEXAGONAL	7.304-386.0	3
2	S-RING 28X1,2 / SPRING CLIP / CIRCLIP	7.343-151.0	4	39	KLEMMLEISTE / STRIP TERMINAL / BORNE PLATE	6.952-056.0	1
3	KUGELLAGER 6001-2RS / BALL BEARING / ROULEMENT A BILLE	7.401-111.0	2	40	DICHTLEISTE / SEALING STRIP / BAGUETTE D'ETANCHEITE	6.362-695.0	1
4	SPANNROLLE / ADJUSTER / GALET TENDEUR	6.952-092.0	1	41	DICHTLEISTE / SEALING STRIP / BAGUETTE D'ETANCHEITE	6.362-696.0	1
5	HALTER / BRACKET / FIXATION	6.952-047.0	1	42	KLEMMLEISTE / STRIP TERMINAL / BORNE PLATE	6.643-357.0	1
6	PLATTE / PLATE / PLAQUE	6.952-048.0	1				
7	6KT-SCHR. M 6X 18 / HEXAGONAL HEAD SCREW / VIS HEXAGONAL	7.304-384.0	4				
8	SCHEIBE 6 / WASHER / RONDELLE	7.312-003.0	10				
9	6KT-MUTTER M 6 / HEXAGON NUT / ECROU HEXAGONAL	7.311-425.0	12				
11	PASSCHEI. 15X21X0,5 / WASHER / RONDELLE	7.343-217.0	2				
13	KEILRIEMENSCHIEBE / PULLEY / POULIE EN V	6.952-049.0	1				
14	KEILRIEMEN 8X1020 / LARGE V-BELT / COURROIE TRAPEZOID.	7.348-073.0	1				
15	BOLZEN / BOLT / BOULON	6.316-056.0	2				
16	GABELKOPF / FORK HEAD / CHAPE	6.952-051.0	2				
17	SCHEIBE 6 / WASHER / RONDELLE	7.312-276.0	2				
18	6KT-MUTTER M 6 / HEXAGON NUT / ECROU HEXAGONAL	7.311-003.0	3				
19	FEDERRING B 6 / SPRING WASHER / RONDELLE GROWER	7.313-003.0	2				
20	GEWINDESTANGE / ROD / TIGE FILETEE	6.952-050.0	1				
21	WINKEL / ANGLE / ANGLE	6.952-058.0	1				
22	6KT-MUTTER M10 / HEXAGON NUT / ECROU HEXAGONAL	7.311-423.0	1				
23	SCHEIBE 10 / WASHER / RONDELLE	7.312-285.0	1				
25	GEWINDESTANGE / ROD / TIGE FILETEE	6.952-052.0	1				
26	DICHTLEISTE / SEALING STRIP / BAGUETTE D'ETANCHEITE	6.362-694.0	1				
27	STREBE KPL. / STAY / ENTRETOISE	6.370-096.0	1				
28	BESENSCHWINGE-RECHT / BROOM ARM / BRAS DE BALAI	6.952-054.0	1				
29	KEILRIEMENSCHIEBE / PULLEY / POULIE EN V	6.952-053.0	1				
30	ABSTANDSHUELSE / DISTANCE SLEEVE / DOUILLE D'ECARTEMENT	6.952-055.0	1				
31	S-RING 35X1,5 / SPRING CLIP / CIRCLIP	7.343-167.0	2				
32	KUGELLAGER 6202-2RS / BALL BEARING / ROULEMENT A BILLE	7.401-128.0	1				
33	PASSFEDER 5X 5X 20 / SPRING / RESSORT D'ADJUSTAGE	7.318-070.0	1				
34	BUERSTE / BRUSH / BROSSE	6.903-354.0	1				
35	ZYL.SCHR. M10X 35 / CHEESE HEAD SCREW / VIS A TETE CYLINDR.	7.306-074.0	2				
36	FEDERRING B 10 / SPRING WASHER / RONDELLE GROWER	7.313-005.0	2				
37	KLEMMLEISTE / STRIP TERMINAL / BORNE PLATE	6.952-057.0	1				

"=> xxxxxx" = bis Werknummer / up to serial No. / jusqu' au No. de fabr. / "xxxxxx =>" = ab Werknummer / from serial No. / a partir du No. de fabr. /

GRUPPE: 9.0 KEHRWALZE ANTRIEB-L  
GROUP: 9.0 REVERSING ROLLING MILL  
GRUPPE: 9.0 TAMBOUR

**A9**

**KSM 900 B**

**GRUPPE: 9.0 KEHRWALZE ANTRIEB-L**  
**GROUP: 9.0 REVERSING ROLLING MILL**  
**GRUPPE: 9.0 TAMBOUR**

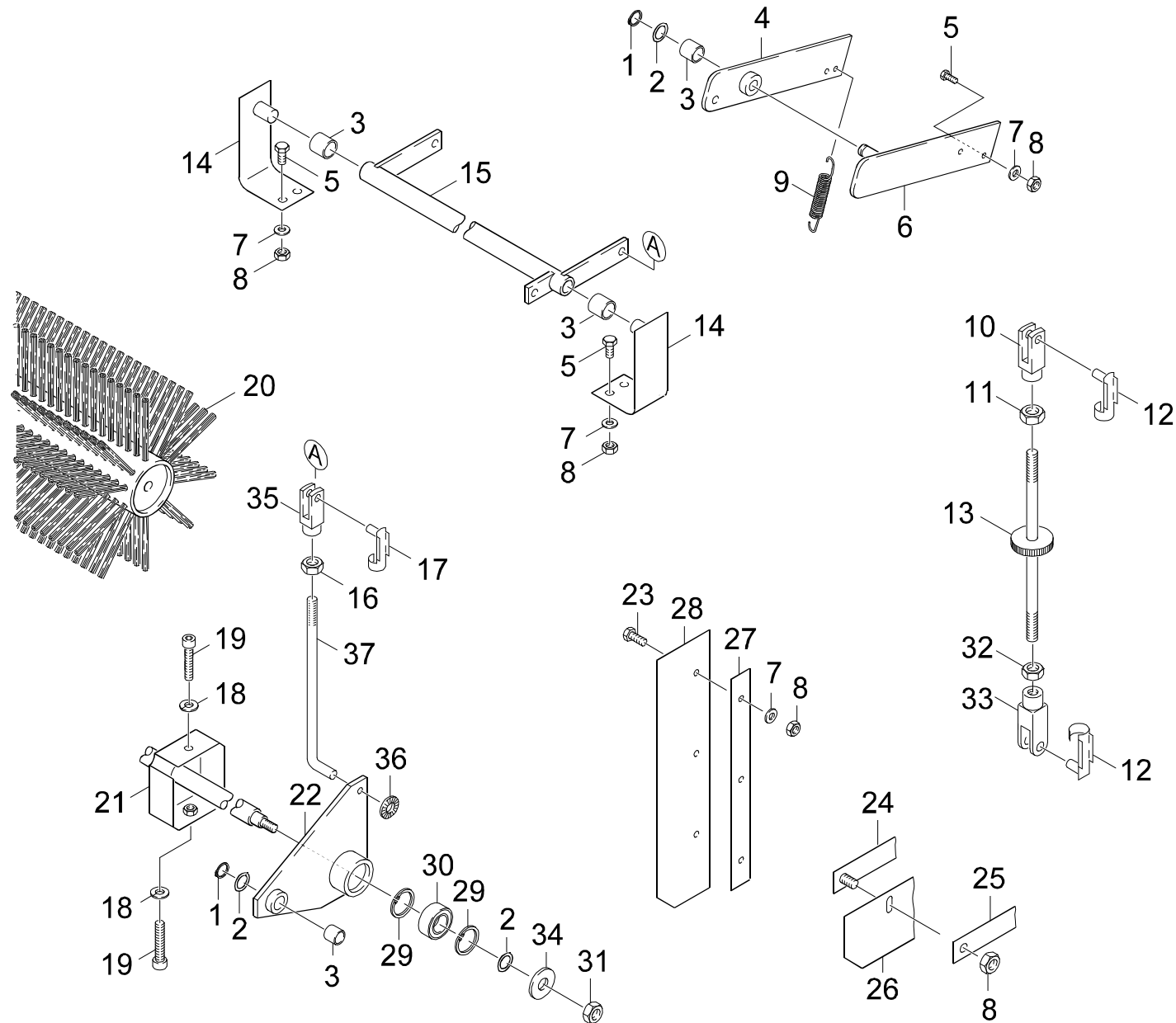

Symbolbeschreibung siehe M16 / symbol description see M16 / désignation de système voir M16 /

GRUPPE: 9.0 KEHRWALZE ANTRIEB-L  
 GROUP: 9.0 REVERSING ROLLING MILL  
 GROUPE: 9.0 TAMBOUR

C9

KSM 900 B

POS. ITM. POS.	BENNENNUNG DESCRIPTION DESIGNATION	TEILE-NR. PART-NO. NO.PIECE	STCK QTY. NBR.	POS. ITM. POS.	BENNENNUNG DESCRIPTION DESIGNATION	TEILE-NR. PART-NO. NO.PIECE	STCK QTY. NBR.
1	S-RING 15X1 / SPRING CLIP / CIRCLIP	7.343-004.0	2	31	6KT-MUTTER M10 / HEXAGON NUT / ECROU HEXAGONAL	7.311-423.0	1
2	PASSCHEI. 15X21X0,5 / WASHER / RONDELLE	7.343-217.0	3	32	6KT-MUTTER M 8 / HEXAGON NUT / ECROU HEXAGONAL	7.311-004.0	1
3	DU-BUCHSE 15X17X15 / BUSH / DOUILLE	6.952-059.0	4	33	GABELKOPF G 8X32 / FORK HEAD / CHAPE	7.462-013.0	1
4	HEBEL / LEVER / LEVIER	6.952-060.0	1	34	SCHEIBE 10 / WASHER / RONDELLE	7.312-005.0	1
5	6KT-SCHR. M 6X 18 / HEXAGONAL HEAD SCREW / VIS HEXAGONAL	7.304-384.0	6	35	GABELKOPF G 6X24 / FORK HEAD / CHAPE	7.462-012.0	1
6	HALTER / BRACKET / FIXATION	6.952-061.0	1	36	SICHERUNGSSCHEIBE / LOCK WASHER / RONDELLE D'ARRET	6.343-173.0	1
7	SCHEIBE 6 / WASHER / RONDELLE	7.312-003.0	9	37	GEWINDESTANGE / ROD / TIGE FILETEE	6.952-065.0	1
8	6KT-MUTTER M 6 / HEXAGON NUT / ECROU HEXAGONAL	7.311-425.0	11				
9	ZUGFEDER / EXTENSION SPRING / RESSORT DE TRACTION	6.330-041.0	1				
10	GABELKOPF G 8X32-LH / FORK HEAD / CHAPE	7.462-014.0	1				
11	6KT-MUTTER M 8-LH / HEXAGON NUT / ECROU HEXAGONAL	7.311-075.0	1				
12	BOLZEN / BOLT / BOULON	6.316-054.0	2				
13	STELLSTANGE / BAR / TIGE	6.952-062.0	1				
14	WINKEL / ANGLE / ANGLE	6.952-063.0	2				
15	SCHALTWELLE / SHAFT / ARBRE	6.952-064.0	1				
16	6KT-MUTTER M 6 / HEXAGON NUT / ECROU HEXAGONAL	7.311-003.0	1				
17	BOLZEN / BOLT / BOULON	6.316-056.0	1				
18	FEDERRING B 10 / SPRING WASHER / RONDELLE GROWER	7.313-005.0	2				
19	ZYL.SCHR. M10X 35 / CHEESE HEAD SCREW / VIS A TETE CYLINDR.	7.306-074.0	2				
20	BUERSTE / BRUSH / BROSSE <b>PERLON/PERLON/PERLON</b>	6.903-345.0	1				
20	BUERSTE / BRUSH / BROSSE <b>POLYESTER/POLYESTER/POLYESTER</b>	6.903-346.0	1				
20	BUERSTE / BRUSH / BROSSE <b>NATUR/NATURE/NATURE</b>	6.903-354.0	1				
21	BESENWELLE / OPERATING LEVER / LEVIER DE MANOEUVRE	6.952-066.0	1				
22	BESENSCHWINGE / BROOM ARM / BRAS DE BALAI	6.952-067.0	1				
23	6KT-SCHR. M 6X 25 / HEXAGONAL HEAD SCREW / VIS HEXAGONAL	7.304-386.0	3				
24	KLEMMLEISTE / STRIP TERMINAL / BORNE PLATE	6.643-357.0	1				
25	KLEMMLEISTE / STRIP TERMINAL / BORNE PLATE	6.952-056.0	1				
26	DICHTLEISTE / SEALING STRIP / BAGUETTE D'ETANCHEITE	6.362-696.0	1				
27	KLEMMLEISTE / STRIP TERMINAL / BORNE PLATE	6.952-057.0	1				
28	DICHTLEISTE / SEALING STRIP / BAGUETTE D'ETANCHEITE	6.362-695.0	1				
29	S-RING 35X1,5 / SPRING CLIP / CIRCLIP	7.343-167.0	2				
30	KUGELLAGER 6202-2RS / BALL BEARING / ROULEMENT A BILLE	7.401-128.0	1				

"=> xxxxxx" = bis Werknummer / up to serial No. / jusqu' au No. de fabr. / "xxxxxx =>" = ab Werknummer / from serial No. / a partir du No. de fabr. /

GRUPPE: 10.0FILTERANLAGE  
GROUP: 10.0FILTER INSTALLATION  
GRUPPE: 10.0INSTALLATION DE FILTRE

**A10**

**KSM 900 B**

**GRUPPE: 10.0FILTERANLAGE**  
**GROUP: 10.0FILTER INSTALLATION**  
**GRUPPE: 10.0INSTALLATION DE FILTRE**

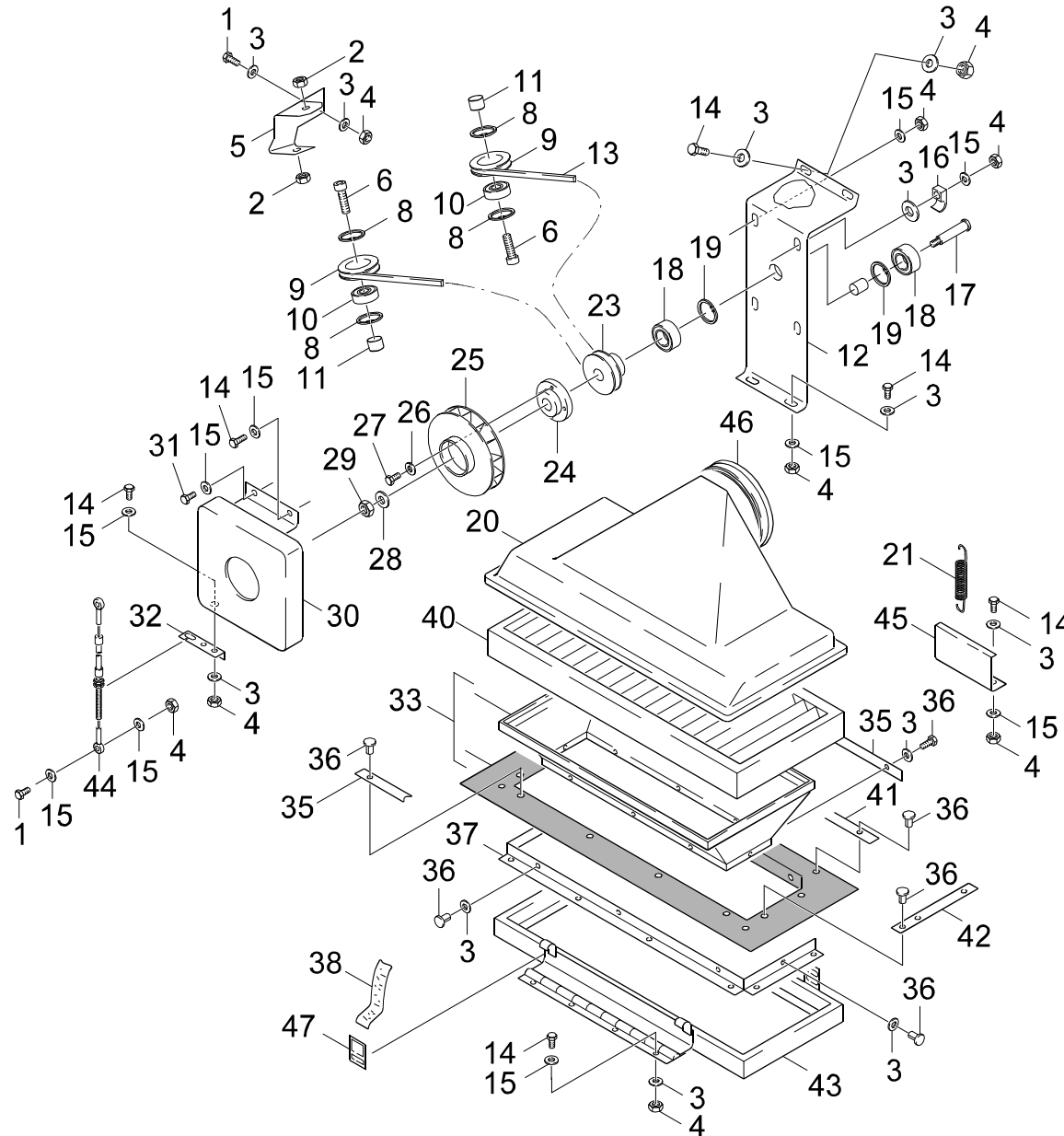

Symbolbeschreibung siehe M16 / symbol description see M16 / désignation de système voir M16 /

GRUPPE: 10.0FILTERANLAGE  
 GROUP: 10.0FILTER INSTALLATION  
 GROUPE: 10.0INSTALLATION DE FILTRE

# C10

# KSM 900 B

POS. ITM. POS.	BENNENNUNG DESCRIPTION DESIGNATION	TEILE-NR. PART-NO. NO.PIECE	STCK QTY. NBR.	POS. ITM. POS.	BENNENNUNG DESCRIPTION DESIGNATION	TEILE-NR. PART-NO. NO.PIECE	STCK QTY. NBR.
1	SCHRAUBE M 6X 20 / SCREW / VIS	7.306-092.0	3	38	SPANNBAND / BANNER / BANDEROLE	6.370-089.0	2
2	6KT-MUTTER M10 / HEXAGON NUT / ECROU HEXAGONAL	7.311-423.0	2	40	PLATTENFILTER / FILTER PANEL / FITRE	6.904-063.0	1
3	SCHEIBE 6 / WASHER / RONDELLE	7.312-276.0	38	41	KLEMMLEISTE / STRIP TERMINAL / BORNE PLATE	6.952-078.0	1
4	6KT-MUTTER M 6 / HEXAGON NUT / ECROU HEXAGONAL	7.311-425.0	18	42	KLEMMLEISTE / STRIP TERMINAL / BORNE PLATE	6.952-079.0	1
5	ROLLENHALTER / TAPE ROLL HOLDER / SUPPORT ROULETTES	6.952-068.0	1	43	RAHMEN / FRAME / CADRE	6.952-080.0	1
6	ZYL.SCHR. M10X 30 / CHEESE HEAD SCREW / VIS A TETE CYLINDR.	7.306-063.0	2	44	BOWDENZUG / BOWDEN WIRE / CABLE SOUS GAINÉ	6.431-068.0	1
8	S-RING 26X 1,2 / SPRING CLIP / CIRCLIP	7.343-232.0	4	45	WINKEL / ANGLE / ANGLE	6.952-071.0	1
9	RIEMENSCHLEIBE / PULLEY / POULIE	6.348-210.0	2	46	DICHTUNGSPROFIL / PROFILED JOINT / JOINT D'ETANCHEITE PROF.	6.365-329.0	1
10	KUGELLAGER 6000-2RS / BALL BEARING / ROULEMENT A BILLE	7.401-091.0	2	47	LASCHE / RETAINER CLIP / ECLISSE	6.903-843.0	2
11	ABSTANDSHUELSE / DISTANCE SLEEVE / DOUILLE D'ECARTEMENT	6.952-072.0	3				
12	HALTER / BRACKET / FIXATION	6.952-069.0	1				
13	POLY-V-RIEMEN / V-BELT / COURROIE TRAPEZOID.	6.348-204.0	1				
14	SCHRAUBE M 6X 16 / SCREW / VIS	7.306-090.0	15				
15	SCHEIBE 6 / WASHER / RONDELLE	7.312-003.0	15				
16	KABELSCHELLE / CABLE CLIP / COLLIER DE CABLE	6.647-089.0	1				
17	WELLE / SHAFT / ARBRE	6.903-479.0	1				
18	KUGELLAGER 6001-2RS / BALL BEARING / ROULEMENT A BILLE	7.401-111.0	2				
19	S-RING 28X1,2 / SPRING CLIP / CIRCLIP	7.343-151.0	2				
20	FILTERHAUBE / COVER OF FILTER / CAPOT DE FILTRE	6.952-070.0	1				
21	ZUGFEDER / EXTENSION SPRING / RESSORT DE TRACTION	6.330-043.0	1				
23	RIEMENSCHLEIBE / PULLEY / POULIE	6.952-076.0	1				
24	FLANSCH / FLANGE / BRIDE	6.952-075.0	1				
25	LUEFTERRAD / BLOWER WHEEL / ROUE DE VENTILATEUR	6.952-074.0	1				
26	FEDERRING B 6 / SPRING WASHER / RONDELLE GROWER	7.313-003.0	4				
27	SCHRAUBE M 6X 10 / SCREW / VIS	7.306-087.0	4				
28	SCHEIBE 8 / WASHER / RONDELLE	7.312-277.0	1				
29	6KT-MUTTER M 8 / HEXAGON NUT / ECROU HEXAGONAL	7.311-427.0	1				
30	HAUBE / COVER / CAPOT	6.952-073.0	1				
31	6KT-SCHR. M 6X 30 / HEXAGONAL HEAD SCREW / VIS HEXAGONAL	7.304-387.0	1				
32	WINKEL / ANGLE / ANGLE	6.952-084.0	1				
33	FILTERKASTEN / FILTER BOX / FILTRE	6.952-082.0	1				
35	KLEMMLEISTE / STRIP TERMINAL / BORNE PLATE	6.952-077.0	2				
36	SPREIZNIET / RIVET / RIVET A EXPANSION	6.952-081.0	23				
37	RAHMEN / FRAME / CADRE	6.952-083.0	1				

"=> xxxxxx" = bis Werknummer / up to serial No. / jusqu' au No. de fabr. / "xxxxxx =>" = ab Werknummer / from serial No. / a partir du No. de fabr. /

GRUPPE: 11.0SEITENBESENANLAGE  
GROUP: 11.0SIDE BRUSH INSTALLATION  
GRUPPE: 11.0ENSEMBLE BALAI LATERAL

**A11**

**KSM 900 B**

**GRUPPE: 11.0SEITENBESENANLAGE**  
**GROUP: 11.0SIDE BRUSH INSTALLATION**  
**GRUPPE: 11.0ENSEMBLE BALAI LATERAL**



GRUPPE: 11.0 SEITENBESENANLAGE  
GROUP: 11.0 SIDE BRUSH INSTALLATION  
GRUPPE: 11.0 ENSEMBLE BALAI LATERAL

B11

KSM 900 B

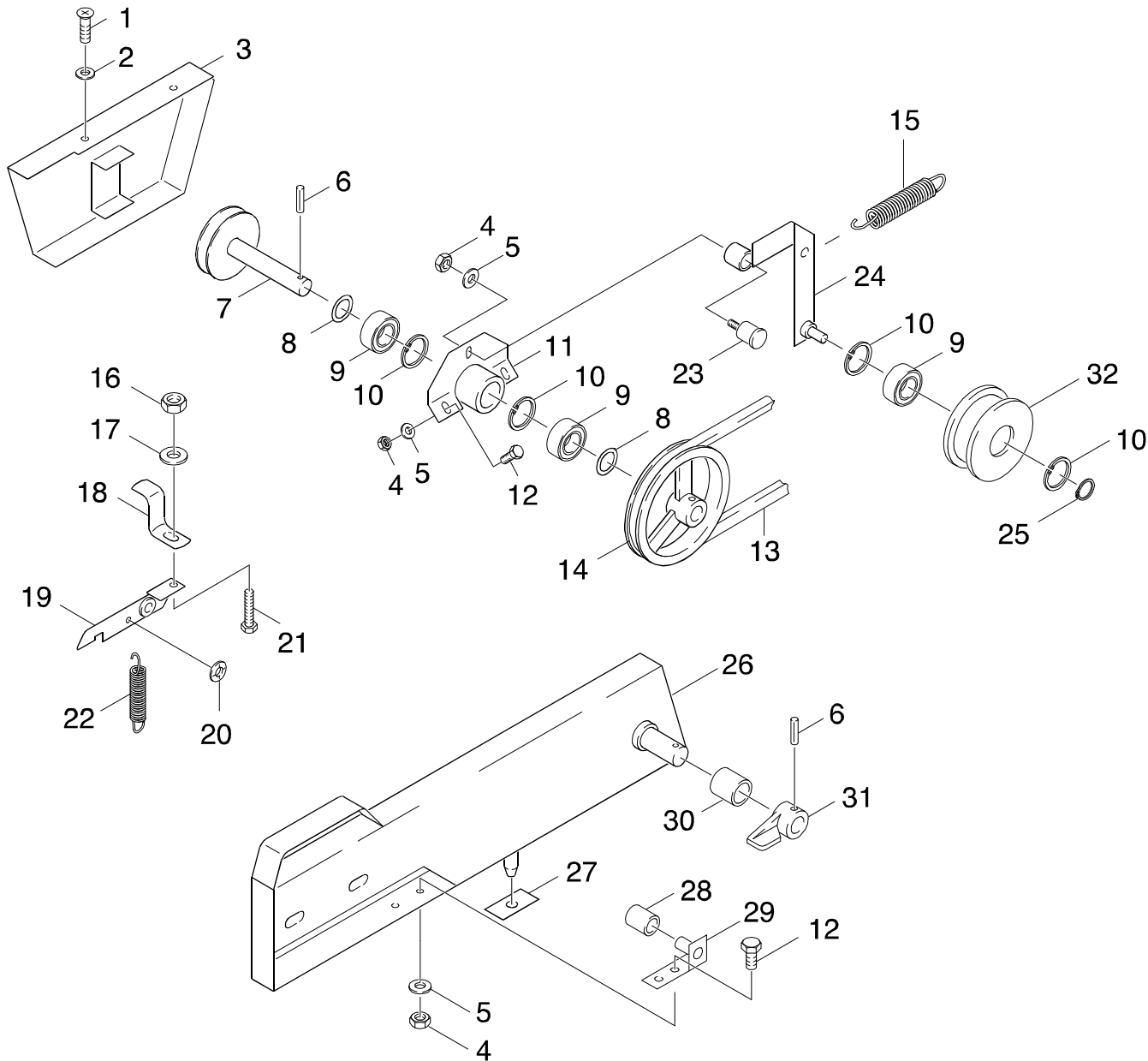

Symbolbeschreibung siehe M16 / symbol description see M16 / désignation de système voir M16 /

GRUPPE: 11.0 SEITENBESEANLAGE  
 GROUP: 11.0 SIDE BRUSH INSTALLATION  
 GROUPE: 11.0 ENSEMBLE BALAI LATERAL

**C11**

**KSM 900 B**

POS. ITM. POS.	BENNENUNG DESCRIPTION DESIGNATION	TEILE-NR. PART-NO. NO.PIECE	STCK QTY. NBR.
1	SCHNEIDSCHR. M5X 16 / SELF-TAPPING SCREW / VIS AUTOTARAUEUSE	7.303-513.0	2
2	HOHLSCHEIBE / HOLLOW DISC / DISQUE (DOUBLE EN.)	6.952-021.0	2
3	VERKLEIDUNGSBLECH / COATING SHEET / TOLE DE COFFRAGE	6.952-085.0	1
4	6KT-MUTTER M 6 / HEXAGON NUT / ECROU HEXAGONAL	7.311-425.0	5
5	SCHEIBE 6 / WASHER / RONDELLE	7.312-276.0	5
6	SPANNSTIFT 5,0X28 / PIN / GOUPILLE DE SERRAGE	7.314-945.0	1
7	RIEMENSCHLEIBE / PULLEY / POULIE	6.952-086.0	1
8	PASSSCHEIBE 12X18X1 / WASHER / RONDELLE	7.343-212.0	5
9	KUGELLAGER 6001-2RS / BALL BEARING / ROULEMENT A BILLE	7.401-111.0	3
10	S-RING 28X1,2 / SPRING CLIP / CIRCLIP	7.343-151.0	4
11	HALTER / BRACKET / FIXATION	6.952-090.0	1
12	SCHRAUBE M 6X 16 / SCREW / VIS	7.306-090.0	4
13	KEILRIEMEN / LARGE V-BELT / COURROIE TRAPEZOID.	6.348-191.0	1
14	KEILRIEMENSCHLEIBE / PULLEY / POULIE EN V	6.952-089.0	1
15	ZUGFEDER / EXTENSION SPRING / RESSORT DE TRACTION	6.330-045.0	1
16	6KT-MUTTER M 6 / HEXAGON NUT / ECROU HEXAGONAL	7.311-003.0	1
17	FAECHERSCHLEIBE A6,4 / SERRATED LOCK WASHER / RONDELLE A EVENTAIL	7.312-232.0	1
18	WINKEL / ANGLE / ANGLE	6.952-087.0	1
19	HEBEL / LEVER / LEVIER	6.952-088.0	1
20	SICHERUNGSSCHLEIBE / LOCK WASHER / RONDELLE D'ARRET	6.343-174.0	1
21	6KT-SCHR. M 6X 25 / HEXAGONAL HEAD SCREW / VIS HEXAGONAL	7.304-386.0	1
22	ZUGFEDER / EXTENSION SPRING / RESSORT DE TRACTION	6.330-044.0	1
23	BOLZEN / BOLT / BOULON	6.316-055.0	1
24	HEBEL / LEVER / LEVIER	6.952-091.0	1
25	S-RING 12X1 / SPRING CLIP / CIRCLIP	7.343-003.0	1
26	BESENARM / BROOM ARM / BRAS DE BALAI	6.952-093.0	1
27	PLATTE / PLATE / PLAQUE	6.952-094.0	1
28	BUCHSE / BUSH / DOUILLE	6.952-095.0	1
29	HALTER / BRACKET / FIXATION	6.952-096.0	1
30	DU-BUCHSE 15X17X15 / BUSH / DOUILLE	6.952-059.0	1
31	HAKEN / HOOK / PATERE	6.373-537.0	1
32	SPANNROLLE / ADJUSTER / GALET TENDEUR	6.952-092.0	1

"=> xxxxxx" = bis Werknummer / up to serial No. / jusqu' au No. de fabr. / "xxxxxx =>" = ab Werknummer / from serial No. / a partir du No. de fabr. /

GRUPPE: 12.0SEITENBESENANTRIEB  
GROUP: 12.0SIDE BRUSH DRIVE  
GRUPPE: 12.0ENTRAINEM. BALAI LATERAL

**A12**

**KSM 900 B**

**GRUPPE: 12.0SEITENBESENANTRIEB**  
**GROUP: 12.0SIDE BRUSH DRIVE**  
**GRUPPE: 12.0ENTRAINEM. BALAI LATERAL**

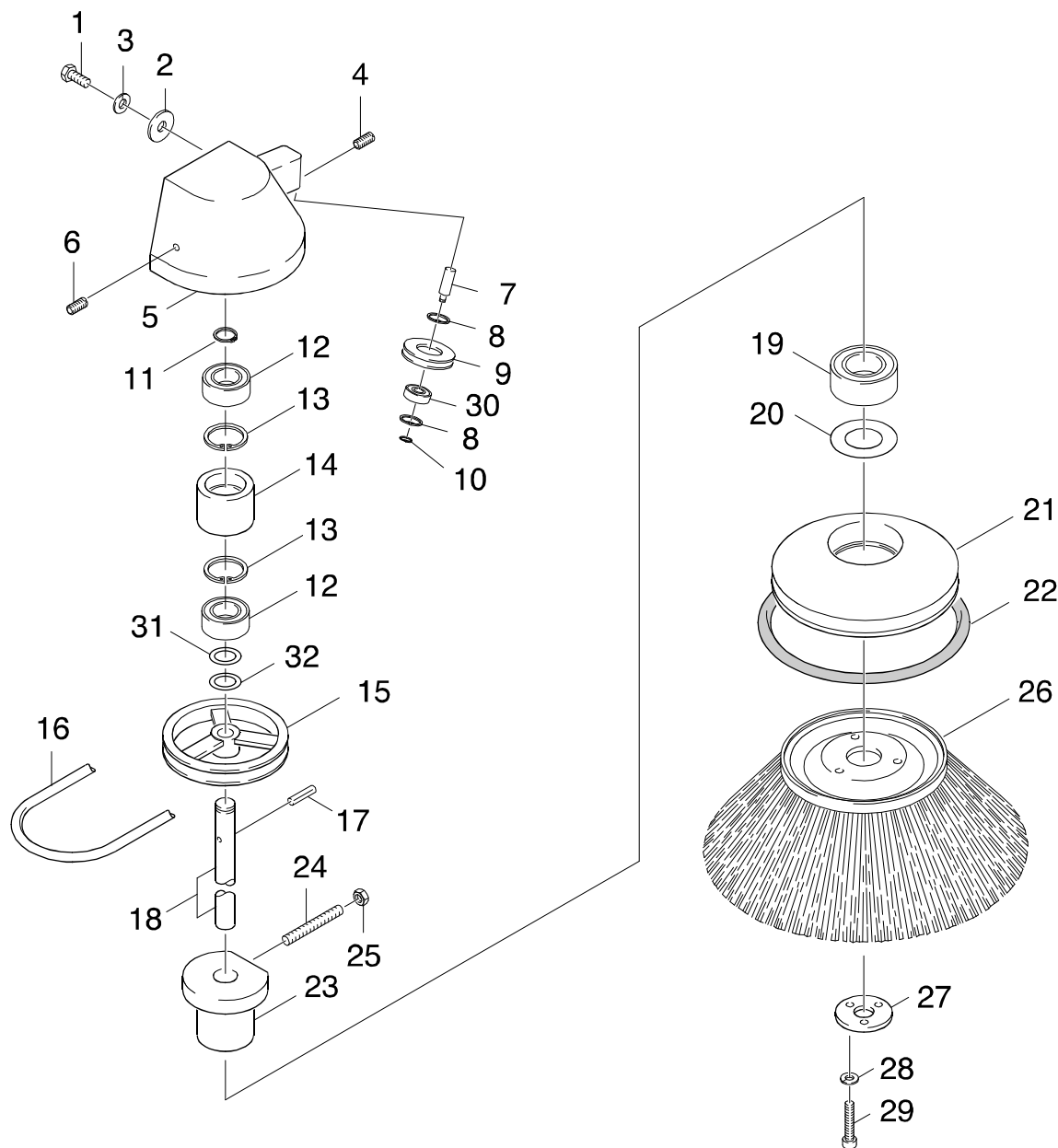

Symbolbeschreibung siehe M16 / symbol description see M16 / désignation de système voir M16 /

GRUPPE: 12.0 SEITENBESENANTRIEB  
 GROUP: 12.0 SIDE BRUSH DRIVE  
 GROUPE: 12.0 ENTRAINEM. BALAI LATERAL

# C12

# KSM 900 B

POS. ITM. POS.	BENNENUNG DESCRIPTION DESIGNATION	TEILE-NR. PART-NO. NO.PIECE	STCK QTY. NBR.
1	ZYL.SCHR. M 8X 20 / CHEESE HEAD SCREW / VIS A TETE CYLINDR.	7.306-041.0	2
2	SCHEIBE 8 / WASHER / RONDELLE	7.312-277.0	2
3	FEDERRING 8 / SPRING WASHER / RONDELLE GROWER	7.313-051.0	2
4	GEW.STIFT M 6X 14 / THREADED PIN / VIS SANS TETE	7.307-352.0	1
5	GEHAEUSE / HOUSING / BOITIER	6.952-097.0	1
6	GEW.STIFT M 8X 16 / THREADED PIN / VIS SANS TETE	7.307-355.0	1
7	BOLZEN / BOLT / BOULON	6.952-098.0	1
8	S-RING 26X 1,2 / SPRING CLIP / CIRCLIP	7.343-232.0	2
9	RIEMENSCHLEIBE / PULLEY / POULIE	6.348-209.0	1
10	S-RING 10X1 / SPRING CLIP / CIRCLIP	7.343-001.0	1
11	S-RING 20X1,2 / SPRING CLIP / CIRCLIP	7.343-007.0	1
12	KUGELLAGER 6004-2RS / BALL BEARING / ROULEMENT A BILLE	7.401-133.0	2
13	S-RING 42X1,75 / SPRING CLIP / CIRCLIP	7.343-114.0	2
14	BUCHSE / BUSH / DOUILLE	6.952-099.0	1
15	RIEMENSCHLEIBE / PULLEY / POULIE	6.952-100.0	1
16	RUNDRIEMEN / BELT / COURROIE RONDE	6.348-192.0	1
17	SPANNSTIFT 5,0X28 / PIN / GOUPILLE DE SERRAGE	7.314-945.0	1
18	WELLE / SHAFT / ARBRE	6.952-101.0	1
19	KUGELLAGER 6009-2RS / BALL BEARING / ROULEMENT A BILLE	7.401-163.0	1
20	PASSCHEI. 45X55X1,0 / WASHER / RONDELLE	7.343-219.0	4
21	BESENTELLER / BROMM PLATE / PLATEAU DE BALAI	6.903-480.0	1
22	GUMMIRING / RUBBER RING / RONDELLE CAOUTCHOUC	6.362-698.0	1
23	BESENNABE / HUB / MOYEU	6.952-102.0	1
24	GEWINDESTIFT M 8 X 30 / THREADED PIN / VIS SANS TETE	7.307-356.0	1
25	6KT-MUTTER M 8 / HEXAGON NUT / ECROU HEXAGONAL	7.311-004.0	1
26	SEITENBESEN / SIDE BROOM / BALAI	6.903-347.0	1
27	DRUCKPLATTE / PRINTING PLATE / PLAQUE	6.370-097.0	1
28	FEDERRING B 6 / SPRING WASHER / RONDELLE GROWER	7.313-003.0	3
29	6KT-SCHR. M 6X 25 / HEXAGONAL HEAD SCREW / VIS HEXAGONAL	7.304-386.0	3
30	KUGELLAGER 6000-2RS / BALL BEARING / ROULEMENT A BILLE	7.401-091.0	1
31	PASSCHEI. 20X28X0,5 / WASHER / RONDELLE	7.343-214.0	2
32	PASSCHEI. 20X28X0,2 / WASHER / RONDELLE	7.343-218.0	1

"=> xxxxxx" = bis Werknummer / up to serial No. / jusqu' au No. de fabr. / "xxxxxx =>" = ab Werknummer / from serial No. / a partir du No. de fabr. /

GRUPPE: 13.0E-AUSRUESTUNG  
GROUP: 13.0ELECTRIC EQUIPMENT  
GRUPPE: 13.0EQUIPEMENT ELECTRIQUE

**A13**

**KSM 900 B**

**GRUPPE: 13.0E-AUSRUESTUNG**  
**GROUP: 13.0ELECTRIC EQUIPMENT**  
**GRUPPE: 13.0EQUIPEMENT ELECTRIQUE**

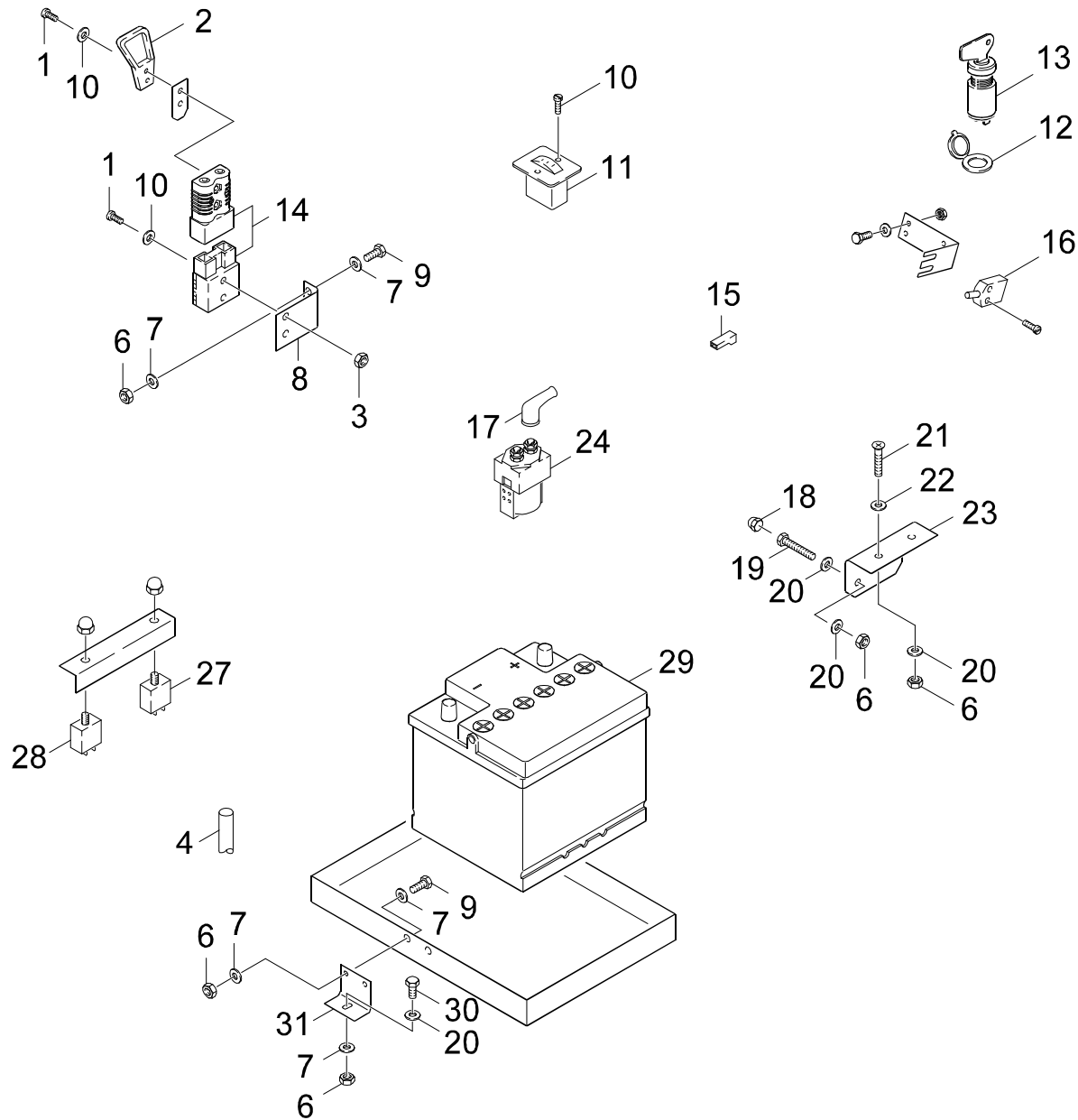

Symbolbeschreibung siehe M16 / symbol description see M16 / désignation de système voir M16 /

GRUPPE: 13.0E-AUSRUESTUNG  
 GROUP: 13.0ELECTRIC EQUIPMENT  
 GROUPE: 13.0EQUIPEMENT ELECTRIQUE

**C13**

**KSM 900 B**

POS. ITM. POS.	BENNENNUNG DESCRIPTION DESIGNATION	TEILE-NR. PART-NO. NO.PIECE	STCK QTY. NBR.
1	ZYL.SCHR. M 3X 25 / CHEESE HEAD SCREW / VIS A TETE CYLINDR.	7.306-401.0	2
2	GRIF / HANDLE / POIGNEE	6.321-084.0	1
3	6KT-MUTTER M 3 / HEXAGON NUT / ECROU HEXAGONAL	7.311-433.0	2
4	SCHLAUCH B10X0,7 / HOSE / TUYAU FLEXIBLE	7.641-040.0	1
6	6KT-MUTTER M 6 / HEXAGON NUT / ECROU HEXAGONAL	7.311-425.0	12
7	SCHEIBE 6 / WASHER / RONDELLE	7.312-003.0	14
8	WINKEL / ANGLE / ANGLE	6.952-108.0	1
9	SCHRAUBE M 6X 16 / SCREW / VIS	7.306-090.0	6
10	SCHEIBE 3 / WASHER / RONDELLE	7.312-294.0	2
11	ANZEIGEINSTRUMENT / INDICATING INSTRUMENT / INDICATEUR	6.681-049.0	1
12	KLAPPDECKEL / HINGED COVER / COUVERCLE A RESSORT	6.631-612.0	1
13	ZUENDSCHLOSS / IGNITION LOCK / SERRURE DE CONTACT	6.375-130.0	1
14	STECKER 50A-2POL / PLUG / FICHE	6.646-140.0	2
15	GEHAEUSE F. HUELSE / HOUSING / BOITIER	6.952-103.0	10
16	KONTAKTSCHALTER / SWITCH / INTERRUPTEUR	6.631-698.0	1
17	SCHUTZKAPPE / PROTECTIVE CAP / CAPOT PROTECTION	6.368-145.0	4
18	SCHUTZKAPPE / PROTECTIVE CAP / CAPOT PROTECTION	6.952-106.0	2
19	6KT-SCHR. M 6X 30 / HEXAGONAL HEAD SCREW / VIS HEXAGONAL	7.304-387.0	2
20	SCHEIBE 6 / WASHER / RONDELLE	7.312-276.0	8
21	SENKSCHR. M 6X 25 / FLAT HEADED SCREW / VIS A TETE CONIQUE	7.305-267.0	2
22	HOHLSCHEIBE / HOLLOW DISC / DISQUE (DOUBLE EN.)	6.952-025.0	2
23	WINKEL / ANGLE / ANGLE	6.952-105.0	1
24	MAGNETSCHALTER / SOLE NOID SWITCH / INTERRUPTEUR MAGNETIQUE	6.631-594.0	1
27	SCHUTZSCHALTER / SAFETY SWITCH / DISJONCTEUR DE PROTECTION	6.631-588.0	1
28	SCHUTZSCHALTER / SAFETY SWITCH / DISJONCTEUR DE PROTECTION	6.952-107.0	1
29	ANTRIEBSBATTERIE / BATTERY / BATTERIE	6.654-018.0	2
30	SCHRAUBE M 6X 20 / SCREW / VIS	7.306-092.0	2
31	WINKEL / ANGLE / ANGLE	6.952-104.0	2

"=> xxxxxx" = bis Werknummer / up to serial No. / jusqu' au No. de fabr. / "xxxxxx =>" = ab Werknummer / from serial No. / a partir du No. de fabr. /



## Bestellhinweis

Bei Ihrer Bestellung sind unbedingt anzugeben :

- |   |   |  |   |   |
|---|---|--|---|---|
| <b>1.</b><br>Gerätetyp<br>Machine model<br>Type d'appareils | <b>2.</b><br>Herstell-Nr.<br>Serial-No.<br>No. de série | <b>3.</b><br>Benennung<br>Description<br>Désignation | <b>4.</b><br>Teile-Nr.<br>Part No.<br>Référence | <b>5.</b><br>Stückzahl<br>Piece No.<br>Quantité |
|---|---|--|---|---|



**siehe Typenschild  
see name-plate  
voir plaque signalétique**



**siehe Ersatzteilliste  
see spare parts list  
voir liste des pièces de rechange**

- Die Ersatzteile, welche als Meterware geliefert werden, sind auf Einbaulänge selbst zu kürzen. Ebenso sind die Stückzahlen in den jeweiligen Gruppen als Mindestbestellmengen = 1m angegeben und können je nach Bedarf auf weitere volle Meterzahlen erhöht und bestellt werden.
- Spare Parts which are delivered as cut goods have to be shortened to installation length. The quotation of quantity in each group refers to the minimum order quantity = 1m and may be ordered and raised to further full metre-values according to demand
- Les pièces de rechange qui sont livrées comme marchandise au mètre sont à raccourcir selon la longueur d'installation. Les indications de quantité dans chaque group se réfèrent à des valeurs de mètre de plus.
- Diese Ersatzteilliste erscheint in gedruckter Form sowie als Mikrofiche. Bei Querverweisen bezieht sich die Angabe "Seitenzahl" auf die gedruckte Ersatzteilliste und die Angabe "Bildtafel" auf die Mikrofilmausgabe.
- This spare parts list is published both in printed form and as a microfiche. In the cross-references, "page number" refers to the printed spare parts list and "display table" to the microfilm edition.
- Cette liste de pièces de rechange est aussi bien imprimée que publiée sous forme de microfiche. Les indications transversales renvoient au "numéro de page" sur la liste imprimée des pièces de rechange et à la "planche" sur la microfiche.

Bitte beachten Sie, daß der Teileumfang dieser Ersatzteilliste nicht unbedingt dem Lieferumfang Ihres Gerätes entspricht.

For your information: It could be that certain parts quoted in this spare parts list were not included with the machine delivery.

Pour votre information: il se peut que certaines pièces détachées mentionnées sur la liste ne vous aient pas été livrées avec l'appareil.

Die in dieser Ersatzteilliste nicht aufgeführten Einzelteile, bestellen Sie bitte direkt beim Vertragskundendienst des jeweiligen Herstellers.

Please order the individual parts not included in this assembly directly with the contract aftersales service of the manufacturer in question.

Veillez s'il vous plaît, commander les pièces détachées qui ne sont indiquées dans notre liste des pièces détachées, directement auprès du service après-vente des fabricants en question.

Bei Bestellung von lackierten Teilen, welche in der Ersatzteilliste nicht in verschiedenen Farben ausgewiesen sind, ist zusätzlich die Farbnummer oder Farbe mit anzugeben. Diese finden Sie auf dem Typenschild oder Farbschild Ihres Gerätes.

Upon ordering of varnished parts which are not mentioned in the spare parts list as parts with different colors, kindly additionally mention the number of the color. It can be seen on the type plate of the color plate of your machine.

Commandant des parts vernissés qui ne sont pas mentionnés comme parts avec une couleur différente dans la liste des pièces détachées, veuillez mentionner de plus le numéro de la couleur. Il se trouve sur la plaque signalétique ou la plaque de couleur de votre machine.

Auflistungen von Einzelteilen bei Ersatzteil - u. Pumpensets sind in der Reihe "16" einzusehen, bzw. direkt unter dem entsprechenden Set aufgelistet.

Listings of single parts upon spare parts kits and pump kits can be seen in row "16" or directly listed below the corresponding kit.  
Des établissements des pièces détachées en ce qui concerne les kits des pièces de rechange et les kits de pompes, peuvent être vus à la ligne "16" ou ils sont répertoriés directement au-dessous du jeu correspondant.

Technische Änderungen im Rahmen der Weiterentwicklung sowie das Recht der ausschließlichen Auswertung unseres geistigen Eigentums behalten wir uns vor. Vervielfältigung und Nachdruck nur mit Genehmigung und Urheberhinweis möglich.

We reserve the right to make technical changes in the course of development work and the right to make exclusive use of our intellectual property. This spare parts list may be duplicated or reprinted only with our approval and with acknowledgement of our copyright.

Nous nous réservons le droit de toutes modifications techniques dans le cadre du perfectionnement des mises au point ainsi que le droit de la mise en valeur exclusive de notre propriété intellectuelle. Polycopie et reproduction exclusivement après accord et avec mention de l'auteur.

# INDEX

## M16

## KSM 900 B

GRUPPE: 1.0 VERKLEIDUNG GROUP: 1.0 COVER GRUPPE: 1.0 CARROSSAGE	A1-C1	GRUPPE: 9.0 KEHRWALZE ANTRIEB-L GROUP: 9.0 REVERSING ROLLING MILL GRUPPE: 9.0 TAMBOUR	A9-C9
GRUPPE: 2.0 FAHRGESTELL /SB/LR GROUP: 2.0 CHASSIS GRUPPE: 2.0 CHASSIS	A2-C2	GRUPPE: 10.0FILTERANLAGE GROUP: 10.0FILTER INSTALLATION GRUPPE: 10.0INSTALLATION DE FILTRE	A10-C10
GRUPPE: 3.0 MOTOR GROUP: 3.0 MOTOR GRUPPE: 3.0 MOTEUR	A3-C3	GRUPPE: 11.0SEITENBESENANLAGE GROUP: 11.0SIDE BRUSH INSTALLATION GRUPPE: 11.0ENSEMBLE BALAI LATERAL	A11-C11
GRUPPE: 4.0 BEDIENUNGSELEMENT GROUP: 4.0 OPERATING ELEMENT GRUPPE: 4.0 ELEMENT D'EMPLOI	A4-C4	GRUPPE: 12.0SEITENBESENANTRIEB GROUP: 12.0SIDE BRUSH DRIVE GRUPPE: 12.0ENTRAINEM. BALAI LATERAL	A12-C12
GRUPPE: 5.0 DIFFERENTIALACHSE GROUP: 5.0 DIFFERENTIAL AXLE GRUPPE: 5.0 ESSIEU DE DIFFERENTIEL	A5-C5	GRUPPE: 13.0E-AUSRUESTUNG GROUP: 13.0ELECTRIC EQUIPMENT GRUPPE: 13.0EQUIPEMENT ELECTRIQUE	A13-C13
GRUPPE: 6.0 FAHRANTRIEB TEIL 1 GROUP: 6.0 TRACTION MOTOR GRUPPE: 6.0 ENTRAINEMENT	A6-C6		
GRUPPE: 7.0 FAHRANTRIEB TEIL 2 GROUP: 7.0 TRACTION MOTOR GRUPPE: 7.0 ENTRAINEMENT	A7-C7		
GRUPPE: 8.0 KEHRWALZE ANTRIEB-R GROUP: 8.0 REVERSING ROLLING MILL GRUPPE: 8.0 TAMBOUR	A8-C8		



BEISPIEL: VERSION 1  
EXAMPLE: VERSION 1  
EXEMPLE: VERSION 1

**3.0**

BEISPIEL: SIEHE IN GRUPPE 3  
EXAMPLE: SEE IN GROUP 3  
EXEMPLE: VOIR EN GROUPE 3



WICHTIGER HINWEIS  
IMPORTANT REMARK  
REMARCAQUAGE IMPORTANT

BESTELLMHINWEIS SIEHE M15  
EXAMPLE ORDER SEE M15  
EXEMPLE DE COMMANDE VOIR M15

VARIANTENÜBERSICHT SIEHE L16  
VARIANTS SURVEY SEE L16  
VUE D'ENSEMBLE DE VARIANTS VOIR L16