

Ersatzteilliste
Spare Parts List
Liste des pièces de rechange

HDS 580/610

1.608-121.0	HDS 580/610
1.608-291.0	HDS 580/610
1.618-111.0	HDS 580/610
1.618-291.0	HDS 580/610
1.618-661.0	HDS 580/610
1.618-741.0	HDS 580/610

ET - Bevorratung eingestellt - betroffene Teile gekennzeichnet

spare parts stocking stopped - marked spare parts are no longer available

des pièces de rechange sont pris en stock non plus , pièces concernées sont indiquées

Kopfzeile: Rot



1.608-121.0	HDS 580/610
1.608-291.0	HDS 580/610
1.618-111.0	HDS 580/610
1.618-291.0	HDS 580/610
1.618-661.0	HDS 580/610
1.618-741.0	HDS 580/610

A0011430
05 2002
5.952-001.0

GRUPPE: 1.0 EINZELTEILE
GROUP: 1.0 PIECE PARTS
GRUPPE: 1.0 PIECES CONSTITUANTES

A1

HDS 580/610

GRUPPE: 1.0 EINZELTEILE
GROUP: 1.0 PIECE PARTS
GRUPPE: 1.0 PIECES CONSTITUANTES

GRUPPE: 1.0 EINZELTEILE
GROUP: 1.0 PIECE PARTS
GRUPPE: 1.0 PIÈCES CONSTITUANTES

B1

HDS 580/610

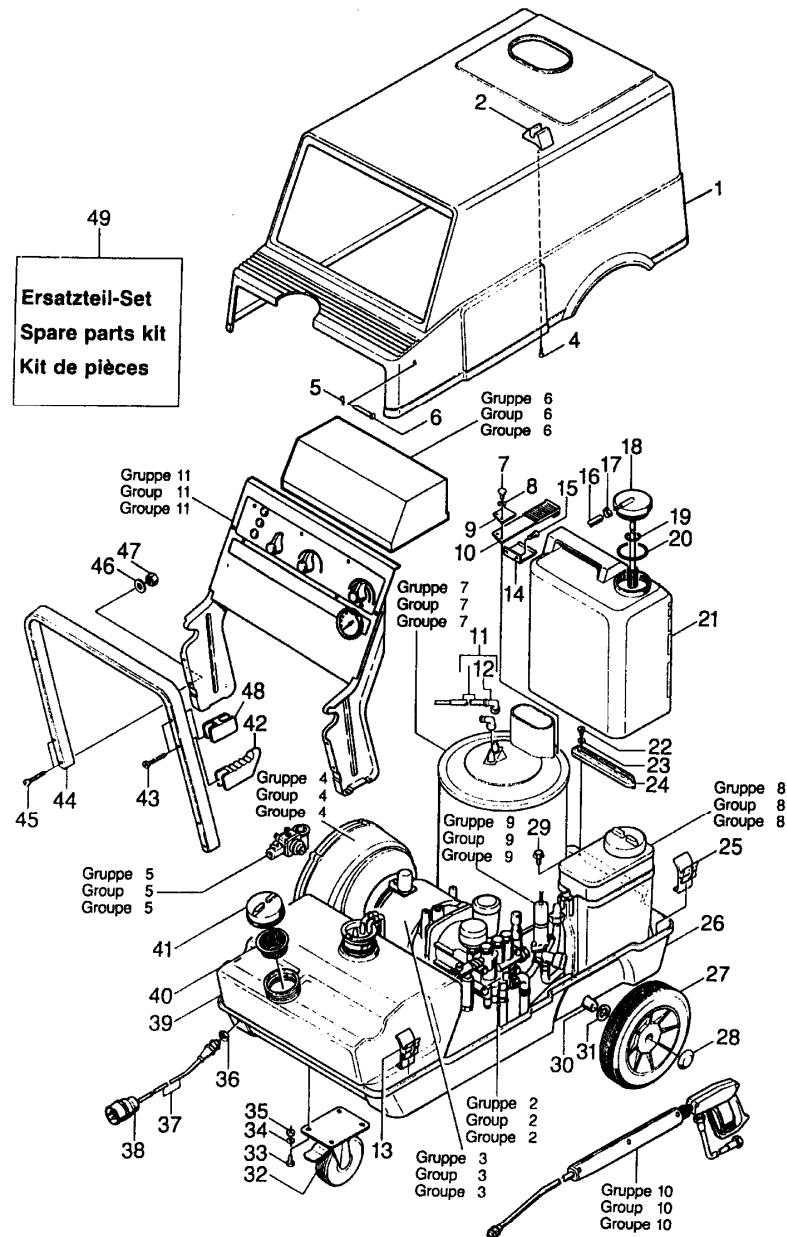

Symbolbeschreibung siehe M16 / symbol description see M16 / désignation de système voir M16 /

GRUPPE: 1.0 EINZELTEILE
 GROUP: 1.0 PIECE PARTS
 GROUPE: 1.0 PIECES CONSTITUANTES

C1

HDS 580/610

POS. ITM. POS.	BENNENNUNG DESCRIPTION DESIGNATION	TEILE-NR. PART-NO. NO.PIECE	STCK QTY. NBR.	POS. ITM. POS.	BENNENNUNG DESCRIPTION DESIGNATION	TEILE-NR. PART-NO. NO.PIECE	STCK QTY. NBR.
1	HAUBE / COVER / CAPOT	5.066-336.0	1	35	6KT-MUTTER M 8 / HEXAGON NUT / ECROU HEXAGONAL	7.311-004.0	4
2	HALTER / BRACKET / FIXATION	5.042-252.0	1	36	GEGENMUTTER PG13.5 / COUNTERNUT / CONTRE-ECROU	6.641-480.0	1
4	LINSENSCHR. 4,2X 13 / OVAL HEAD SCREW / VIS A TETE BOMBEE	6.303-122.0	1	37	KABEL / CABLE / CABLE	4.820-161.0	1
5	SICHERUNG / CLIP / CONSOLIDATION	6.343-006.0	2		/ 1.618-111.0		
6	BOLZEN / BOLT / BOULON	6.373-322.0	2	37	KABEL / CABLE / CABLE	4.820-183.0	1
7	ZYL.SCHR. M 5X 12 / CHEESE HEAD SCREW / VIS A TETE CYLINDR.	7.306-443.0	1	37	KABEL MIT STECKER / CABLE / CABLE	6.641-109.0	1
8	FEDERRING B 5 / SPRING WASHER / RONDELLE GROWER	7.313-002.0	1		/ 1.608-291.0		
9	WINKEL / ANGLE / ANGLE	5.021-953.0	1	37	KABEL MIT STECKER / CABLE / CABLE	6.641-110.0	1
10	HALTER / BRACKET / FIXATION	5.042-257.0	1		/ 1.618-291.0		
11	ZUENDKABEL / IGNITION CABLE / FIL D'AMORCE	4.821-020.0	2	38	CEE-STECKER 16A / CEE-PLUG / CEE-FICHE	6.646-030.0	1
12	KERZENSTECKER / SPARK PLUG SOCKET / COSSE DE BOUGIE	6.618-057.0	2		/ 1.618-111.0 / -291.0		
13	HALTER / BRACKET / FIXATION	5.042-320.0	1	39	TANK / TANK / RESERVOIR	5.071-024.0	1
14	PLATTE / PLATE / PLAQUE	5.002-402.0	1	40	SIEB D 70 / STRAINER / CREPINE	6.414-275.0	1
15	SCHRAUBE M 5X 12 / SCREW / VIS	7.303-038.0	2	41	DECKEL / COVER / COUVERCLE	5.063-217.0	1
16	SCHLAUCH DN 7 / HOSE / TUYAU FLEXIBLE	6.388-225.0	2	42	HALTER / BRACKET / FIXATION	5.042-253.0	2
17	SCHLAUCHSCHELLE / HOSE BAND CLIP / COLLIER DE SERRAGE	6.388-559.0	2	43	BL.SCHR. ST5,5X55,0 / SHEET METAL SCREW / VIS A TOLE	6.305-005.0	3
18	FORMTEIL / MOULDED PART / PREFORME	5.030-355.0	1	44	GRIFF / HANDLE / POIGNEE	5.321-121.0	1
19	O-RING 47,0 X 4,5 / GASKET / BAQUE D'ETANCHEITE	6.362-490.0	1	45	SCHRAUBE M 6X 50 / SCREW / VIS	7.306-133.0	4
20	O-RING 80,0 X 4,5 / GASKET / BAQUE D'ETANCHEITE	6.362-491.0	1	46	SCHEIBE 6 / WASHER / RONDELLE	7.312-276.0	4
21	TANK / TANK / RESERVOIR	5.071-025.0	1	47	6KT-MUTTER M 6 / HEXAGON NUT / ECROU HEXAGONAL	7.311-425.0	4
22	LINSENSCHR. M 5X 16 / OVAL HEAD SCREW / VIS A TETE BOMBEE	7.306-308.0	2	48	HALTER / BRACKET / FIXATION	5.042-254.0	1
23	SCHEIBE 5 / WASHER / RONDELLE	7.312-278.0	2	49	ERSATZTEILSET / SPARE PARTS KIT / KIT DE PIECES	2.880-281.0	1
24	AUFLAGER / SUPPORT / SUPPORT	5.057-024.0	1				
25	HALTER / BRACKET / FIXATION	5.042-256.0	2				
26	RAHMEN / FRAME / CADRE	5.050-005.0	1				
27	SCHEIBENRAD D 250 / WEB DISC WHEEL / ROUE PLEINE	6.435-072.0	2				
28	SCHNELLBEFESTIGER / QUICK-FASTENER / ATTACHE RAPIDE	6.343-137.0	2				
29	SCHRAUBE M 8X 16 / SCREW / VIS	6.303-031.0	2				
30	ACHSE / AXLE / ESSIEU	5.105-063.0	1				
31	SCHEIBE 24 / WASHER / RONDELLE	7.312-060.0	8				
32	LENKROLLE D 125 / CASTOR / ROUE PIVOTANTE	6.435-073.0	1				
33	6KT-SCHR. M 8X 16 / HEXAGONAL HEAD SCREW / VIS HEXAGONAL	7.304-395.0	4				
34	SCHEIBE 8 / WASHER / RONDELLE	7.312-004.0	4				

"=> xxxxxx" = bis Werknummer / up to serial No. / jusqu' au No. de fabr. / "xxxxxx =>" = ab Werknummer / from serial No. / a partir du No. de fabr. /

GRUPPE: 2.0 PUMPENSATZ
GROUP: 2.0 PUMP SET
GRUPPE: 2.0 JEU (ENSEMBLE) DE POMPE

A2

HDS 580/610

GRUPPE: 2.0 PUMPENSATZ
GROUP: 2.0 PUMP SET
GRUPPE: 2.0 JEU (ENSEMBLE) DE POMPE

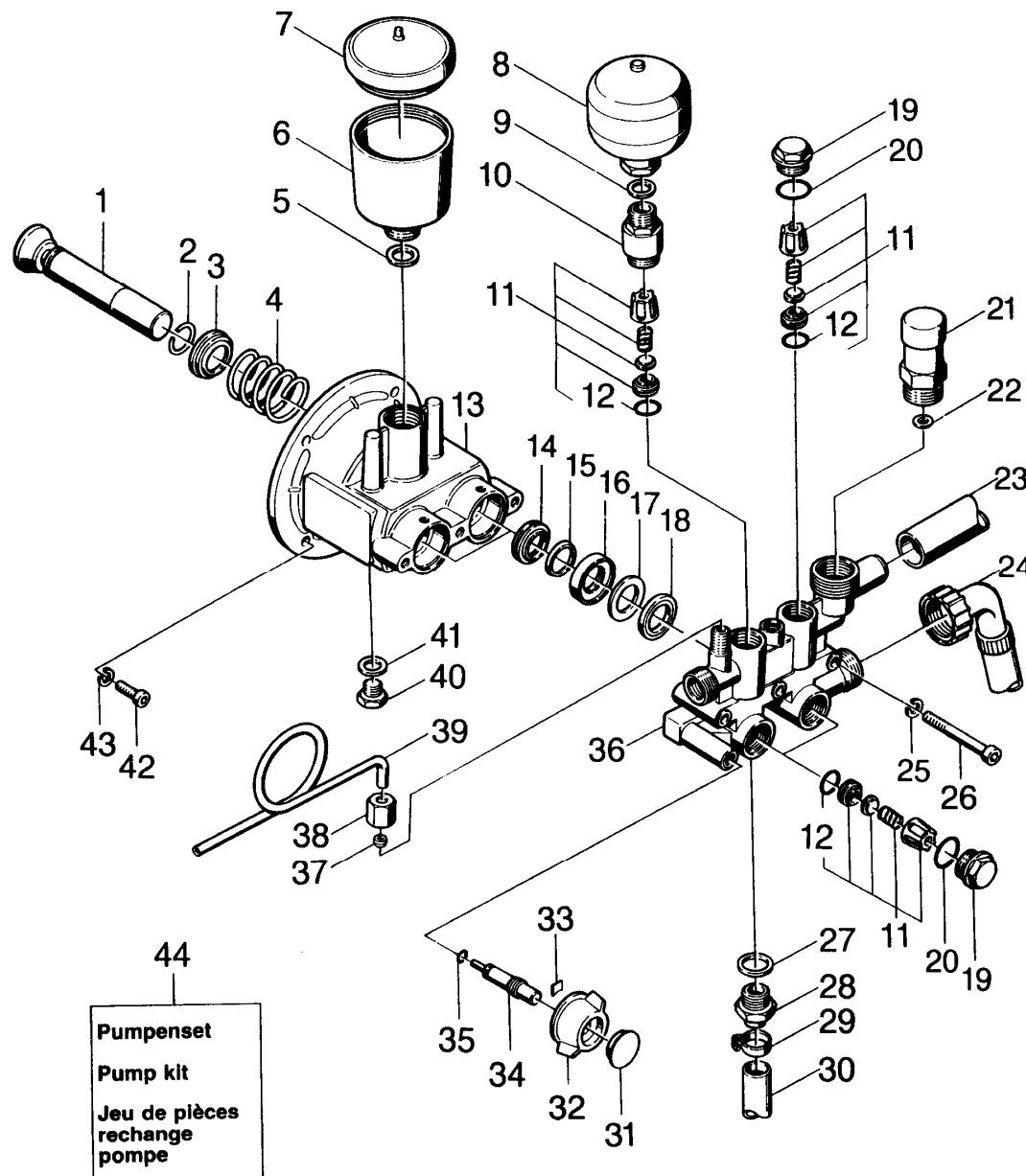

Symbolbeschreibung siehe M16 / symbol description see M16 / désignation de système voir M16 /

GRUPPE: 2.1 PUMPENSATZ / (1.618-291/-111) /
 GROUP: 2.1 PUMP SET / (1.618-291/-111) /
 GROUPE: 2.1 JEU (ENSEMBLE) DE POMPE / (1.618-291/-111) /

C2

HDS 580/610

POS. ITM. POS.	BENNENNUNG DESCRIPTION DESIGNATION	TEILE-NR. PART-NO. NO.PIECE	STCK QTY. NBR.	POS. ITM. POS.	BENNENNUNG DESCRIPTION DESIGNATION	TEILE-NR. PART-NO. NO.PIECE	STCK QTY. NBR.
1	KOLBEN KPL. / PISTON / PISTON	4.553-096.0	2	36	ZYLINDERKOPF / CYLINDER HEAD / CULASSE	4.550-086.0	1
2	SPRENGRING A 20 / SPRING RING / CIRCLIP	7.343-471.0	2	37	SCHNEIDRING D 6-L/S / CUTTING RING / BAGUE COUPANTE	6.386-160.0	2
3	FORMTEIL / MOULDED PART / PREFORME	5.030-296.0	2	38	UE-MUTTER A 6-L / UNION NUT / ECROU RACOURD	6.386-346.0	2
4	SCHRAUBENFEDER / HELICAL SPRING / RESSORT CYLINDRIQUE	5.332-139.0	2	39	LEITUNGSROHR / PIPE / TUBE CONDUCTEUR	5.423-012.0	1
5	DICHTRING / JOINT RING / BAGUE D'ETANCHEITE	5.363-100.0	1	40	VS-SCHRAUBE M12X1,5 / CLOSING SCREW / VIS DE FERMETURE	7.382-232.0	1
6	BEHAELTER / TANK / BAC	5.070-048.0	1	41	DICHTRING 12 X15,5 / JOINT RING / BAGUE D'ETANCHEITE	7.362-004.0	1
7	DECKEL / COVER / COUVERCLE	5.063-189.0	1	42	SCHRAUBE M 6X 30 / SCREW / VIS	7.306-105.0	4
8	DRUCKSPEICHER / PULSATION DAMPER / ANTI-BELIER	6.505-025.0	1	43	FEDERRING 6 / SPRING WASHER / RONDELLE GROWER	7.313-050.0	1
9	DICHTRING 14 X18 / JOINT RING / BAGUE D'ETANCHEITE	7.362-005.0	1	44	PUMPENSET / PUMP SET / GROUPE DE POMPES	2.880-273.0	1
10	VENTILSCHRAUBE / VALVE SCREW / VIS POINTEAU (SOUP.)	5.583-061.0	1				
11	VENTIL KPL. / VALVE / SOUPAPE	4.580-110.0	4				
12	O-RING 13,0 X 2,0 / GASKET / BAQUE D'ETANCHEITE	6.362-381.0	4				
13	GEHAEUSE / HOUSING / BOITIER	5.060-196.0	4				
14	NUTRING 20X28X6/8 / GROOVED RING / JOINT A LEVRES	6.365-052.0	2				
15	O-RING KPL./1ST.-R. / GASKET / BAQUE D'ETANCHEITE	6.362-457.0	2				
16	RING / RING / BAGUE	5.570-058.0	2				
17	SCHEIBE / WASHER / RONDELLE	5.115-224.0	2				
18	NUTRING / GROOVED RING / JOINT A LEVRES	6.365-051.0	2				
19	VENTILSCHRAUBE / VALVE SCREW / VIS POINTEAU (SOUP.)	5.583-115.0	3				
20	O-RING 17,3 X 2,4 / GASKET / BAQUE D'ETANCHEITE	6.362-160.0	4				
21	SICHERHEITSVENTIL / SAFETY VALVE / SOUPAPE (TROP-PLEIN)	6.412-684.0	1				
22	DICHTRING / JOINT RING / BAGUE D'ETANCHEITE	5.363-094.0	1				
23	SCHLAUCHSTUECK / HOSE / BOUT DE TUYAU	5.442-503.0	1				
24	SCHLAUCH / HOSE / TUYAU FLEXIBLE	4.440-271.0	1				
25	FEDERRING 8 / SPRING WASHER / RONDELLE GROWER	7.313-051.0	4				
26	ZYL.SCHR. M 8X 60 / CHEESE HEAD SCREW / VIS A TETE CYLINDR.	7.306-047.0	3				
27	DICHTRING 18 X22 / JOINT RING / BAGUE D'ETANCHEITE	7.362-009.0	1				
28	VENTIL / VALVE / SOUPAPE	4.580-114.0	1				
29	SCHLAUCHSCHELLE / HOSE BAND CLIP / COLLIER DE SERRAGE	6.388-515.0	1				
30	SCHLAUCH DN 7 / HOSE / TUYAU FLEXIBLE	6.388-194.0	1				
31	STOPFEN / PLUG / BOUCHON	5.132-010.0	1				
32	GRIFF / HANDLE / POIGNEE	5.321-138.0	1				
33	SICHERUNGSFEDER / RETAINING SPRING / RESSORT D'ARRET	6.313-003.0	1				
34	FORMSCHRAUBE / SCREW / VIS	5.305-123.0	1				
35	O-RING 5 X 1,5 / GASKET / BAQUE D'ETANCHEITE	6.362-386.0	2				

"=> xxxxxx" = bis Werknummer / up to serial No. / jusqu' au No. de fabr. / "xxxxxx =>" = ab Werknummer / from serial No. / a partir du No. de fabr. /

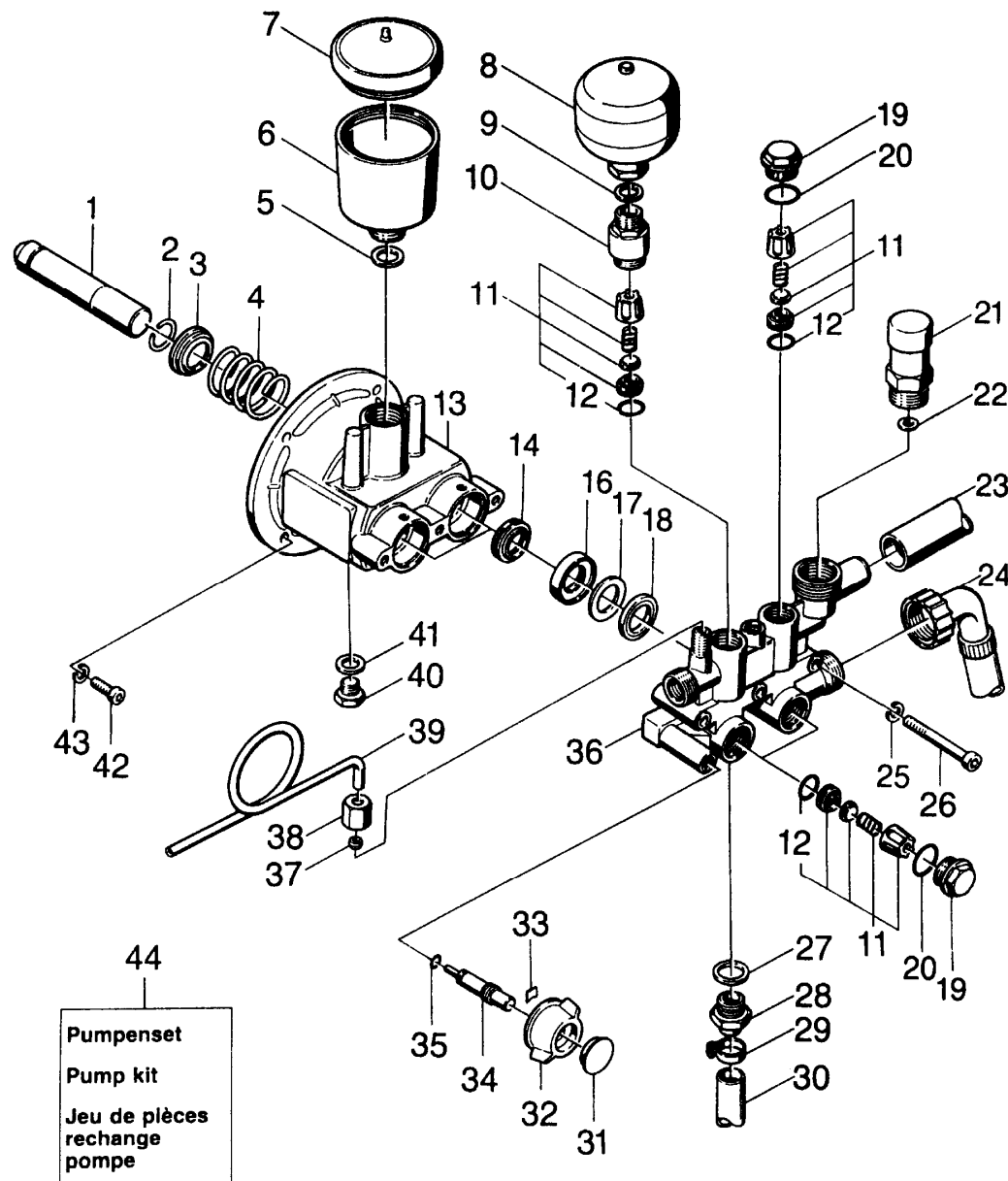

Symbolbeschreibung siehe M16 / symbol description see M16 / désignation de système voir M16 /

GRUPPE: 2.2 PUMPENSATZ / (1.608-291/-121) /
 GROUP: 2.2 PUMP SET / (1.608-291/-121) /
 GROUPE: 2.2 JEU (ENSEMBLE) DE POMPE / (1.608-291/-121) /

E2

HDS 580/610

POS. ITM. POS.	BENNENNUNG DESCRIPTION DESIGNATION	TEILE-NR. PART-NO. NO.PIECE	STCK QTY. NBR.	POS. ITM. POS.	BENNENNUNG DESCRIPTION DESIGNATION	TEILE-NR. PART-NO. NO.PIECE	STCK QTY. NBR.
1	KOLBEN KPL. / PISTON / PISTON	4.553-051.0	2	39	LEITUNGSROHR / PIPE / TUBE CONDUCTEUR	5.423-012.0	1
2	SPRENGRING A 20 / SPRING RING / CIRCLIP	7.343-471.0	2	40	VS-SCHRAUBE M12X1,5 / CLOSING SCREW / VIS DE FERMETURE	7.382-232.0	1
3	FORMTEIL / MOULDED PART / PREFORME	5.030-296.0	2	41	DICHTRING 12 X15,5 / JOINT RING / BAGUE D'ETANCHEITE	7.362-004.0	1
4	SCHRAUBENFEDER / HELICAL SPRING / RESSORT CYLINDRIQUE	5.332-139.0	2	42	SCHRAUBE M 6X 30 / SCREW / VIS	7.306-105.0	4
5	DICHTRING / JOINT RING / BAGUE D'ETANCHEITE	5.363-100.0	1	43	FEDERRING 6 / SPRING WASHER / RONDELLE GROWER	7.313-050.0	1
6	BEHAELTER / TANK / BAC	5.070-048.0	1	44	PUMPENSET / PUMP SET / GROUPE DE POMPES	2.880-274.0	1
7	DECKEL / COVER / COUVERCLE	5.063-189.0	1				
8	DRUCKSPEICHER / PULSATION DAMPER / ANTI-BELIER	6.505-025.0	1				
9	DICHTRING 14 X18 / JOINT RING / BAGUE D'ETANCHEITE	7.362-005.0	1				
10	VENTILSCHRAUBE / VALVE SCREW / VIS POINTEAU (SOUP.)	5.583-061.0	1				
11	VENTIL KPL. / VALVE / SOUPAPE	4.580-110.0	4				
12	O-RING 13,0 X 2,0 / GASKET / BAQUE D'ETANCHEITE	6.362-381.0	4				
13	GEHAEUSE / HOUSING / BOITIER	5.060-196.0	4				
14	NUTRING 20X28X6/8 / GROOVED RING / JOINT A LEVRES	6.365-052.0	2				
16	SCHEIBE / WASHER / RONDELLE	5.115-267.0	2				
17	SCHEIBE / WASHER / RONDELLE	5.115-224.0	2				
18	NUTRING / GROOVED RING / JOINT A LEVRES	6.365-051.0	2				
20	O-RING 17,3 X 2,4 / GASKET / BAQUE D'ETANCHEITE	6.362-160.0	4				
21	SICHERHEITSVENTIL / SAFETY VALVE / SOUPAPE (TROP-PLEIN)	6.412-684.0	1				
22	DICHTRING / JOINT RING / BAGUE D'ETANCHEITE	5.363-094.0	1				
23	SCHLAUCHSTUECK / HOSE / BOUT DE TUYAU	5.442-503.0	1				
24	SCHLAUCH / HOSE / TUYAU FLEXIBLE	4.440-271.0	1				
25	FEDERRING 8 / SPRING WASHER / RONDELLE GROWER	7.313-051.0	4				
26	ZYL.SCHR. M 8X 60 / CHEESE HEAD SCREW / VIS A TETE CYLINDR.	7.306-047.0	3				
27	DICHTRING 18 X22 / JOINT RING / BAGUE D'ETANCHEITE	7.362-009.0	1				
28	VENTIL / VALVE / SOUPAPE	4.580-114.0	1				
29	SCHLAUCHSCHELLE / HOSE BAND CLIP / COLLIER DE SERRAGE	6.388-515.0	1				
30	SCHLAUCH DN 7 / HOSE / TUYAU FLEXIBLE	6.388-194.0	1				
31	STOPFEN / PLUG / BOUCHON	5.132-010.0	1				
32	GRIFF / HANDLE / POIGNEE	5.321-138.0	1				
33	SICHERUNGSFEDER / RETAINING SPRING / RESSORT D'ARRET	6.313-003.0	1				
34	FORMSCHRAUBE / SCREW / VIS	5.305-123.0	1				
35	O-RING 5 X 1,5 / GASKET / BAQUE D'ETANCHEITE	6.362-386.0	2				
36	ZYLINDERKOPF / CYLINDER HEAD / CULASSE	4.550-086.0	1				
37	SCHNEIDRING D 6-L/S / CUTTING RING / BAGUE COUPANTE	6.386-160.0	2				

"=> xxxxxx" = bis Werknummer / up to serial No. / jusqu' au No. de fabr. / "xxxxxx =>" = ab Werknummer / from serial No. / a partir du No. de fabr. /

GRUPPE: 3.0 MOTOR
GROUP: 3.0 MOTOR
GRUPPE: 3.0 MOTEUR

A3

HDS 580/610

GRUPPE: 3.0 MOTOR
GROUP: 3.0 MOTOR
GRUPPE: 3.0 MOTEUR

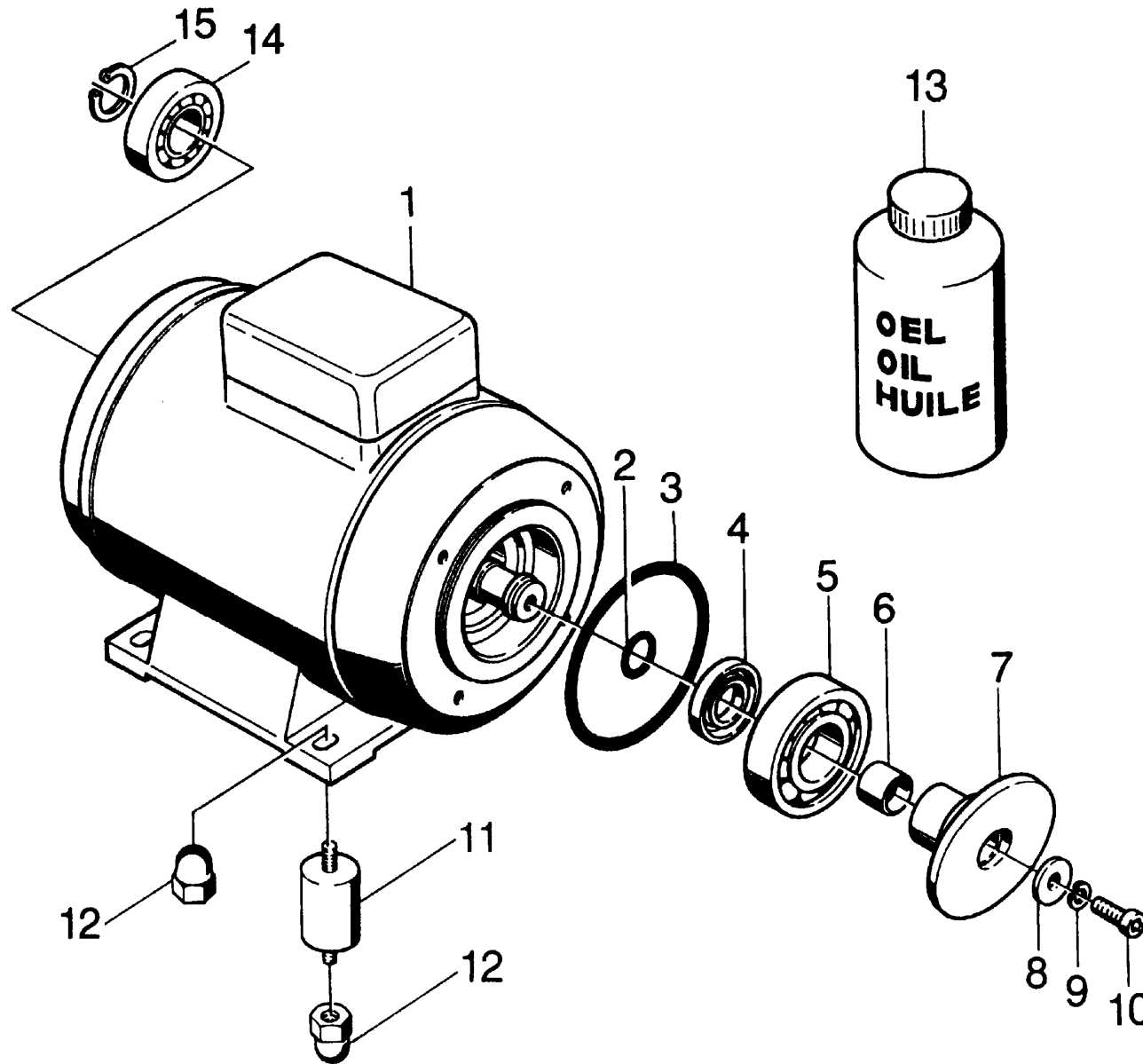

Symbolbeschreibung siehe M16 / symbol description see M16 / désignation de système voir M16 /

GRUPPE: 3.1 MOTOR / (1.618-291/-111) /
GROUP: 3.1 MOTOR / (1.618-291/-111) /
GROUPE: 3.1 MOTEUR / (1.618-291/-111) /

C3

HDS 580/610

POS. ITM. POS.	BENNENUN DESCRIPTION DESIGNATION	TEILE-NR. PART-NO. NO.PIECE	STCK QTY. NBR.
1	E-MOTOR 2,5KW / ELECTRIC MOTOR / MOTEUR ELECTRIQUE	6.611-227.0	1
2	O-RING 14,0 X 1,78 / GASKET / BAQUE D'ETANCHEITE	6.362-395.0	1
3	O-RING 85,0 X 2,0 / GASKET / BAQUE D'ETANCHEITE	6.362-441.0	1
4	W-DICHTRING 30X 42 / ROTARY SHAFT SEAL / JOINT (ARBRE)	6.367-012.0	1
5	KUGELLAGER 7306-B / BALL BEARING / ROULEMENT A BILLE	7.401-033.0	1
6	TOLERANZRING D20X22 / TOLERANCE RING / BAGUE	6.343-011.0	1
7	TAUMELSCHEIBE / SWASH PLATE / DISQUE EN NUTATION	5.120-124.0	1
8	SCHEIBE / WASHER / RONDELLE	6.312-011.0	1
9	FEDERRING 8 / SPRING WASHER / RONDELLE GROWER	7.313-051.0	4
10	ZYL.SCHR. M 8X 20 / CHEESE HEAD SCREW / VIS A TETE CYLINDR.	7.306-041.0	1
11	GUMMIPUFFER M8 / RUBBER BUFFER / BUTOIR CAOUTCHOUC	6.339-060.0	4
12	6KT-MUTTER M 8 / HEXAGON NUT / ECROU HEXAGONAL	7.311-510.0	8
13	GETRIEBEOEL 1L / GEAR LUBRICANT OIL / HUILE A ENGRENAGES	6.288-016.0	1
14	KUGELLAGER 6205 / BALL BEARING / ROULEMENT A BILLE	7.401-123.0	1
15	S-RING 25X1,2 / SPRING CLIP / CIRCLIP	7.343-008.0	1

"=> xxxxxx" = bis Werknummer / up to serial No. / jusqu' au No. de fabr. / "xxxxxx =>" = ab Werknummer / from serial No. / a partir du No. de fabr. /

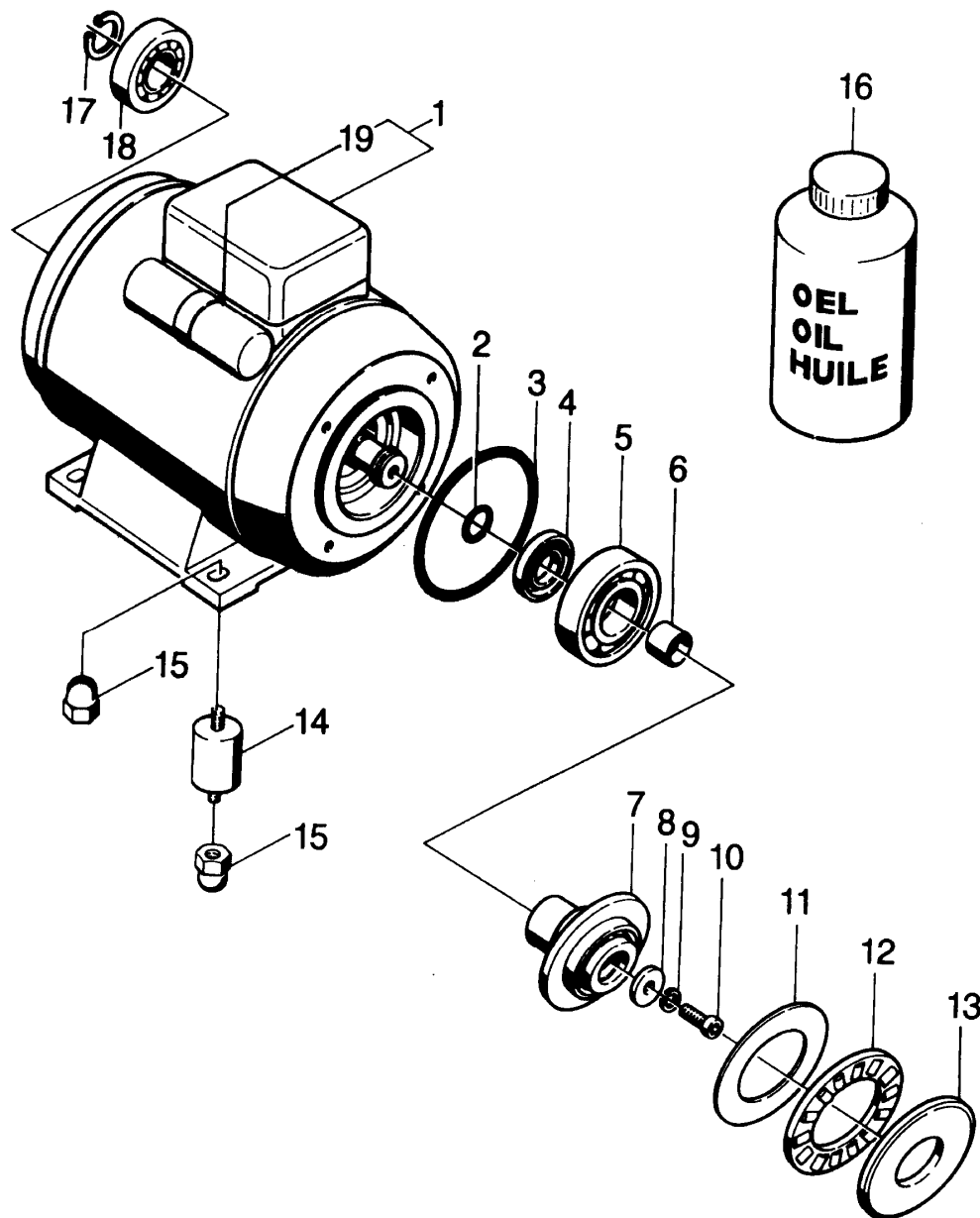

Symbolbeschreibung siehe M16 / symbol description see M16 / désignation de système voir M16 /

GRUPPE: 3.2 MOTOR / (1.608-291/-121) /
GROUP: 3.2 MOTOR / (1.608-291/-121) /
GROUPE: 3.2 MOTEUR / (1.608-291/-121) /

E3

HDS 580/610

POS. ITM. POS.	BENNENUNG DESCRIPTION DESIGNATION	TEILE-NR. PART-NO. NO.PIECE	STCK QTY. NBR.
1	E-MOTOR 1,65KW / ELECTRIC MOTOR / MOTEUR ELECTRIQUE	6.612-172.0	1
2	O-RING 14,0 X 1,78 / GASKET / BAQUE D'ETANCHEITE	6.362-395.0	1
3	O-RING 85,0 X 2,0 / GASKET / BAQUE D'ETANCHEITE	6.362-441.0	1
4	W-DICHTRING 30X 42 / ROTARY SHAFT SEAL / JOINT (ARBRE)	6.367-012.0	1
5	KUGELLAGER 7306-B / BALL BEARING / ROULEMENT A BILLE	7.401-033.0	1
6	TOLERANZRING D20X22 / TOLERANCE RING / BAGUE	6.343-011.0	1
7	TAUMELSCHEIBE / SWASH PLATE / DISQUE EN NUTATION	5.120-118.0	1
8	SCHEIBE / WASHER / RONDELLE	6.312-011.0	1
9	FEDERRING 8 / SPRING WASHER / RONDELLE GROWER	7.313-051.0	4
10	ZYL.SCHR. M 8X 20 / CHEESE HEAD SCREW / VIS A TETE CYLINDR.	7.306-041.0	1
11	LAUFSCHLEIBE / ROTOR DISC / DISQUE DE BUTEE	6.401-125.0	1
12	AXIALROLLENKAEFIG / THRUST ROLLER BEARING / BUTEE A ROULEAUX	6.401-126.0	1
13	DRUCKSCHEIBE / PRESSURE DISC / DISQUE DE PRESSION	6.401-127.0	1
14	GUMMIPUFFER M8 / RUBBER BUFFER / BUTOIR CAOUTCHOUC	6.339-060.0	4
15	6KT-MUTTER M 8 / HEXAGON NUT / ECROU HEXAGONAL	7.311-510.0	8
16	GETRIEBEOEL 1L / GEAR LUBRICANT OIL / HUILE A ENGRENAGES	6.288-016.0	1
17	S-RING 25X1,2 / SPRING CLIP / CIRCLIP	7.343-008.0	1
18	KUGELLAGER 6205 / BALL BEARING / ROULEMENT A BILLE	7.401-123.0	1
19	ZUENDKABEL / IGNITION CABLE / FIL D'AMORCE	6.641-074.0	1

"=> xxxxxx" = bis Werknummer / up to serial No. / jusqu' au No. de fabr. / "xxxxxx =>" = ab Werknummer / from serial No. / a partir du No. de fabr. /

GRUPPE: 4.0 GEBLAESE
GROUP: 4.0 BLOWER
GRUPPE: 4.0 VENTILATEUR

A4

HDS 580/610

GRUPPE: 4.0 GEBLAESE
GROUP: 4.0 BLOWER
GRUPPE: 4.0 VENTILATEUR

GRUPPE: 4.0 GEBLAESE
GROUP: 4.0 BLOWER
GRUPPE: 4.0 VENTILATEUR

B4

HDS 580/610

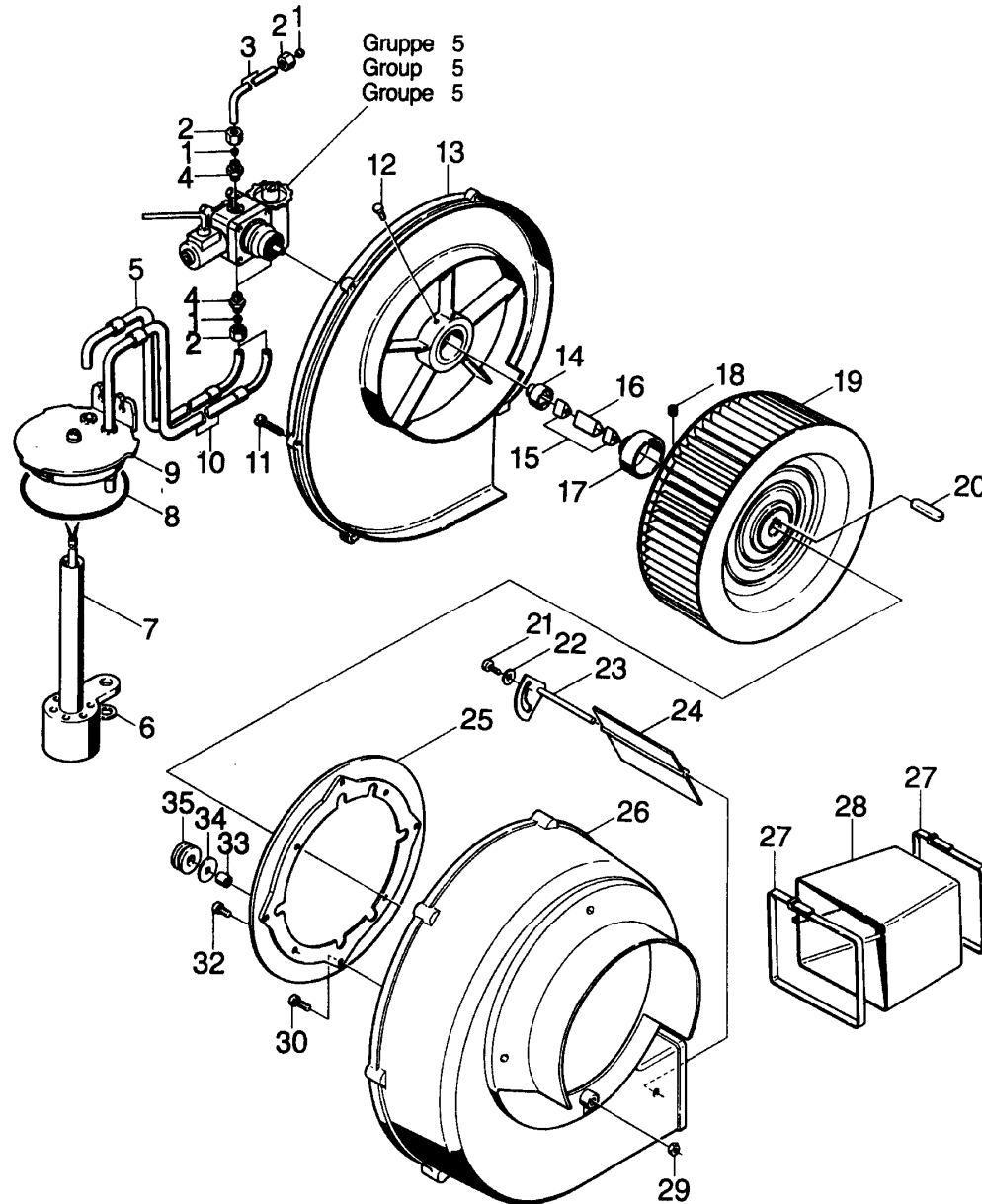

Symbolbeschreibung siehe M16 / symbol description see M16 / désignation de système voir M16 /

GRUPPE: 4.0 GEBLAESE
GROUP: 4.0 BLOWER
GROUPE: 4.0 VENTILATEUR

C4

HDS 580/610

POS. ITM. POS.	BENNENNUNG DESCRIPTION DESIGNATION	TEILE-NR. PART-NO. NO.PIECE	STCK QTY. NBR.
1	SCHNEIDRING D 6-L/S / CUTTING RING / BAGUE COUPANTE	6.386-160.0	4
2	UE-MUTTER A 6-L / UNION NUT / ECROU RACOURD	6.386-346.0	4
3	LEITUNGSROHR / PIPE / TUBE CONDUCTEUR	5.423-013.0	1
4	STUTZEN 6-L1/8NPT / CONNECTION PIECE / TUBULURE	6.386-181.0	3
5	SCHLAUCHLEITUNG / HOSE ASSEMBLY / CONDUITE	6.388-333.0	1
6	SICHERUNGSSCHEIBE / LOCK WASHER / RONDELLE D'ARRET	6.343-119.0	1
7	NIVEAUFUEHLER / LEVEL PROBE / DETECTEUR DE NIVEAU	6.631-439.0	1
8	O-RING 68,0 X 4,0 / GASKET / BAQUE D'ETANCHEITE	6.362-474.0	1
9	FORMTEIL / MOULDED PART / PREFORME	5.030-434.0	1
10	SCHLAUCHLEITUNG / HOSE ASSEMBLY / CONDUITE	6.388-334.0	1
11	BL.SCHR. ST4,8X25-C / SHEET METAL SCREW / VIS A TOLE	7.309-022.0	7
12	SCHRAUBE M 6X 16 / SCREW / VIS	7.306-090.0	1
13	DECKEL / COVER / COUVERCLE	5.063-206.0	1
14	KUPPLUNGSTEIL / COUPLING ELEMENT / PIECE D'ACCOUPL.	6.463-008.0	1
15	KUPPLUNGSTEIL / COUPLING ELEMENT / PIECE D'ACCOUPL.	6.463-020.0	2
16	KUPPLUNGSTEIL / COUPLING ELEMENT / PIECE D'ACCOUPL.	5.471-050.0	1
17	KUPPLUNGSTEIL / COUPLING ELEMENT / PIECE D'ACCOUPL.	5.471-049.0	1
18	GEW.STIFT M 8X 6 / THREADED PIN / VIS SANS TETE	7.307-407.0	1
19	GEBLAESERAD ALU / BLOWER WHEEL / ROUE DE VENTILATEUR	6.484-048.0	1
20	PASSFEDER 5X 5X 16 / SPRING / RESSORT D'ADJUSTAGE	7.318-002.0	1
21	BL.SCHR. ST4,8X16 / SHEET METAL SCREW / VIS A TOLE	7.303-077.0	1
22	SCHEIBE 5 / WASHER / RONDELLE	7.312-278.0	1
23	KLAPPENWELLE / FLAP SHAFT / ESSIEU	5.603-012.0	1
24	LUFTKLAPPE / AIR FLAP / VOLET D'ADMIS.D'AIR	5.606-001.0	1
25	FORMTEIL / MOULDED PART / PREFORME	5.030-370.0	1
26	GEHAEUSE / HOUSING / BOITIER	5.605-078.0	1
27	SPANNBAND / BANNER / BANDEROLE	6.388-608.0	2
28	TUCHMANSCHETTE / CLOTH COLLAR / MANCHETTE	5.178-016.0	1
29	6KT-MUTTER M 6 / HEXAGON NUT / ECROU HEXAGONAL	7.311-422.0	4
30	ZYL.SCHR. M 6X 25 / CHEESE HEAD SCREW / VIS A TETE CYLINDR.	7.306-023.0	4
32	ZYL.SCHR. M 6X 10 / CHEESE HEAD SCREW / VIS A TETE CYLINDR.	7.306-027.0	4
33	HUELSE / SLEEVE / DOUILLE	5.110-222.0	4
34	SCHEIBE / WASHER / RONDELLE	5.115-233.0	4
35	GUMMIRING / RUBBER RING / RONDELLE CAOUTCHOUC	5.379-008.0	4

"=> xxxxxx" = bis Werknummer / up to serial No. / jusqu' au No. de fabr. / "xxxxxx =>" = ab Werknummer / from serial No. / a partir du No. de fabr. /

GRUPPE: 5.0 BRENNSTOFFPUMPE
GROUP: 5.0 FUEL PUMP
GRUPPE: 5.0 POMPE DE COMBUSTIBLE

A5

HDS 580/610

GRUPPE: 5.0 BRENNSTOFFPUMPE
GROUP: 5.0 FUEL PUMP
GRUPPE: 5.0 POMPE DE COMBUSTIBLE

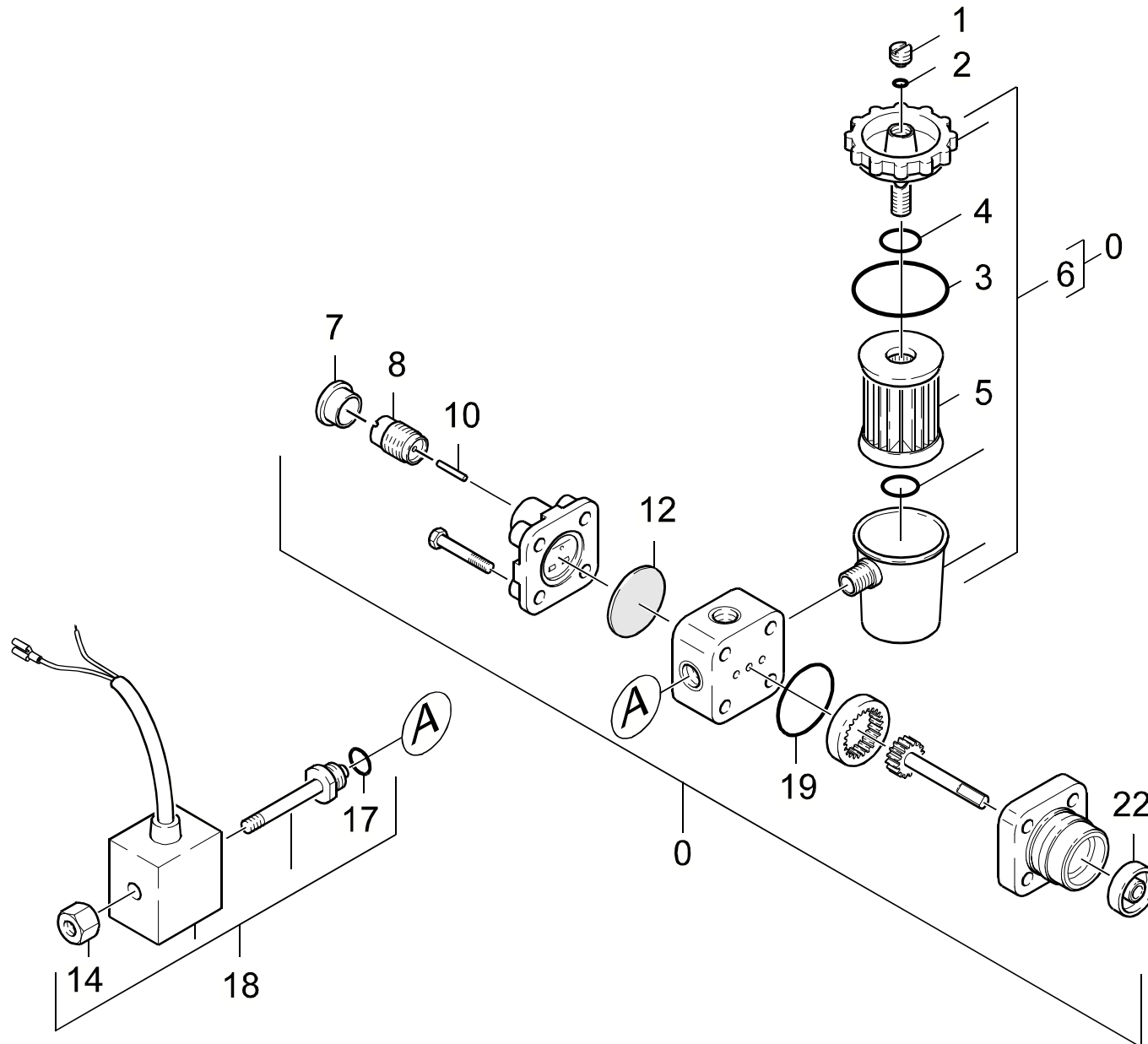

Symbolbeschreibung siehe M16 / symbol description see M16 / désignation de système voir M16 /

GRUPPE: 5.0 BRENNSTOFFPUMPE
GROUP: 5.0 FUEL PUMP
GROUPE: 5.0 POMPE DE COMBUSTIBLE

C5

HDS 580/610

POS. ITM. POS.	BENNENUN G DESCRIPTION DESIGNATION	TEILE-NR. PART-NO. NO.PIECE	STCK QTY. NBR.
0	BRENNSTOFFPUMPE / FUEL PUMP / POMPE DE COMBUSTIBLE	6.472-925.0	1
1	ENTLUEFTUNGSSCHR. / VENT SCREW / VIS D'AIR	6.472-107.0	1
2	O-RING 5,0 X 1,8 / GASKET / BAQUE D'ETANCHEITE	6.472-106.0	1
3	O-RING 32,0 X 1,6 / GASKET / BAQUE D'ETANCHEITE	6.472-111.0	1
4	O-RING 10,0 X 2,4 / GASKET / BAQUE D'ETANCHEITE	6.472-112.0	1
5	FILTEREINSATZ / FILTER CARTRIDGE / CARTOUCHE FILTRANTE	6.472-113.0	1
6	FILTERGEHAEUSE KPL. / FILTER CASE / BATI DE FILTRE	6.472-123.0	1
7	SCHUTZKAPPE / PROTECTING CAP / CAPOT PROTECTION	6.472-122.0	1
8	FEDERGEHAEUSE / SPRING HOUSING / BARILLET	6.472-109.0	1
10	STIFT / PIN / CHEVILLE	6.472-108.0	1
12	MEMBRANE / DIAPHRAGM / MEMBRANE	6.472-128.0	1
14	RAENDELMUTTER / KNURLED NUT / ECROU MOLETE	6.472-340.0	1
17	O-RING 12,0 X 1,5 / GASKET / BAQUE D'ETANCHEITE	6.472-125.0	1
18	MAGNETVENTIL KOMPL. / SOLENOID VALVE / ELECTROVANNE	6.472-389.0	1
19	O-RING 28,5 X 1,6 / GASKET / BAQUE D'ETANCHEITE	6.472-120.0	1
22	ACHSENDICHTUNG / SHAFT SEAL / ETOUPAGE D'ESSIEU	6.472-105.0	1

"=> xxxxxx" = bis Werknummer / up to serial No. / jusqu' au No. de fabr. / "xxxxxx =>" = ab Werknummer / from serial No. / a partir du No. de fabr. /

GRUPPE: 6.0 E-GERAETESCHRANK
GROUP: 6.0 ELECTRIC CONTROL BOX
GRUPPE: 6.0 COFFRET ELECTRIQUE

A6

HDS 580/610

GRUPPE: 6.0 E-GERAETESCHRANK
GROUP: 6.0 ELECTRIC CONTROL BOX
GRUPPE: 6.0 COFFRET ELECTRIQUE

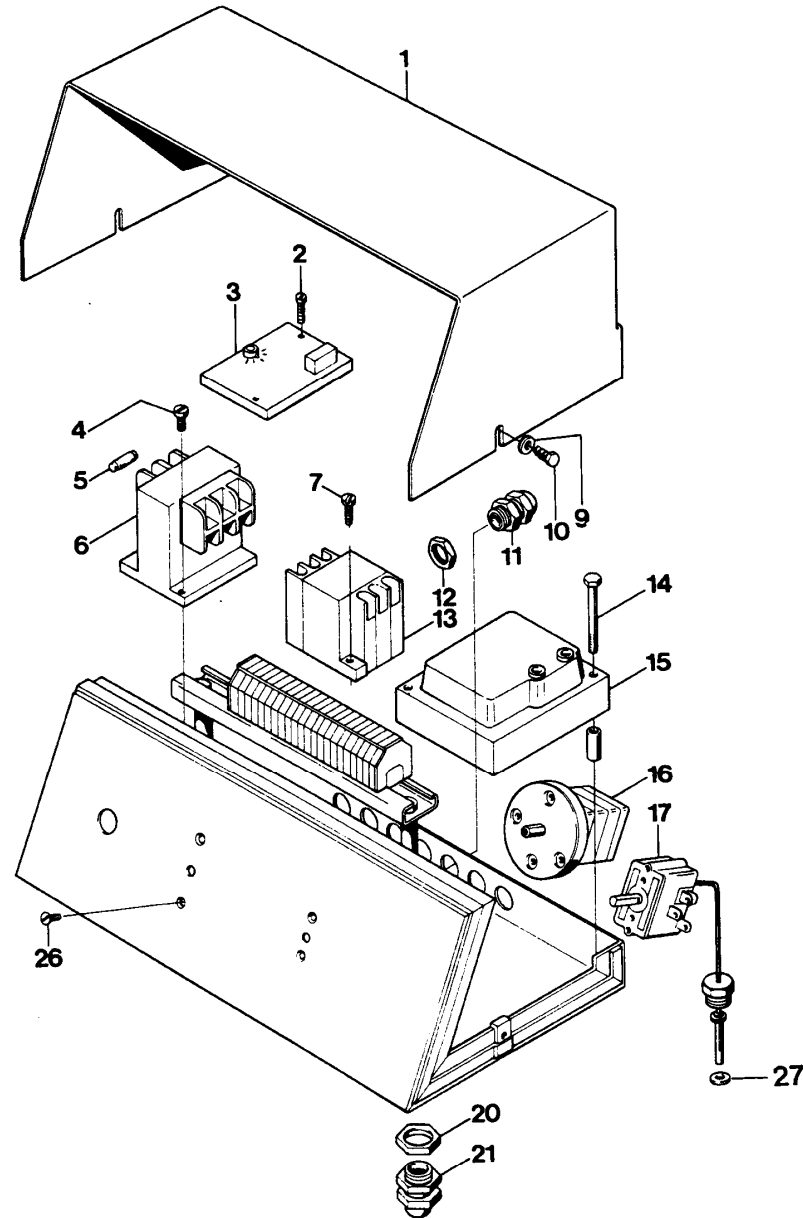

Symbolbeschreibung siehe M16 / symbol description see M16 / désignation de système voir M16 /

GRUPPE: 6.0 E-GERAETESCHRANK
GROUP: 6.0 ELECTRIC CONTROL BOX
GROUPE: 6.0 COFFRET ELECTRIQUE

C6

HDS 580/610

POS. ITM. POS.	BENNENUNG DESCRIPTION DESIGNATION	TEILE-NR. PART-NO. NO.PIECE	STCK QTY. NBR.
1	HAUBE / COVER / CAPOT	5.066-122.0	1
2	SCHNEIDSCHR. M3X 16 / SELF-TAPPING SCREW / VIS AUTOTARAUEUSE	6.303-014.0	2
3	IMPULSGEBER / PULSE GENERATOR / CONTACTEUR	6.633-090.0	1
4	SCHNEIDSCHR. M4X 8 / SELF-TAPPING SCREW / VIS AUTOTARAUEUSE	6.303-017.0	2
5	G-SCHMELZEINSATZ / CARTRIDGE / BOUCHON FUSIBLE	6.644-052.0	1
6	STEUERTRAFO 40VA / TRANSFORMER / TRANSFORMATEUR	6.622-021.0	1
7	SCHRAUBE M 4X 16 / SCREW / VIS	7.303-033.0	2
9	SCHEIBE 5 / WASHER / RONDELLE	7.312-278.0	2
10	BL.SCHR. ST4,8X16,0 / SHEET METAL SCREW / VIS A TOLE	7.303-121.0	2
11	KABELVERSCHR. PG 9 / CABLE CONNECTOR / RACCORD DE CABLES	6.641-355.0	8
12	GEGENMUTTER PG 9 / COUNTERNUT / CONTRE-ECROU	6.641-366.0	8
13	SCHUETZ 24V50HZ / CONTACTOR / CONTACTEUR	6.632-285.0	1
14	SCHRAUBE M 5X 8 / SCREW / VIS	7.303-036.0	2
15	ZUENDTRAFO 220V / TRANSFORMER / TRANSFORMATEUR / 1.608-121.0 / -291.0	6.622-086.0	1
15	ZUENDTRAFO 380V / TRANSFORMER / TRANSFORMATEUR / 1.618-111.0 / -291.0	6.622-087.0	1
16	SCHALTER / SWITCH / INTERRUPTEUR	6.631-081.0	1
17	TEMPERATURREGLER / THERMOSTAT / THERMOSTAT	6.685-375.0	1
20	GEGENMUTTER PG13,5 / COUNTERNUT / CONTRE-ECROU	6.641-369.0	2
21	KABELVERSCHR. / CABLE CONNECTOR / RACCORD DE CABLES	6.641-613.0	2
26	SENKSCHR. M 4X 8 / FLAT HEADED SCREW / VIS A TETE CONIQUE	7.305-021.0	4
27	SCHEIBE / WASHER / RONDELLE	5.115-375.0	1

"=> xxxxxx" = bis Werknummer / up to serial No. / jusqu' au No. de fabr. / "xxxxxx =>" = ab Werknummer / from serial No. / a partir du No. de fabr. /

GRUPPE: 7.0 DURCHLAUFERHITZER
GROUP: 7.0 FLOW HEATER
GRUPPE: 7.0 CHAUFFE-EAU RAPIDE

A7

HDS 580/610

GRUPPE: 7.0 DURCHLAUFERHITZER
GROUP: 7.0 FLOW HEATER
GRUPPE: 7.0 CHAUFFE-EAU RAPIDE

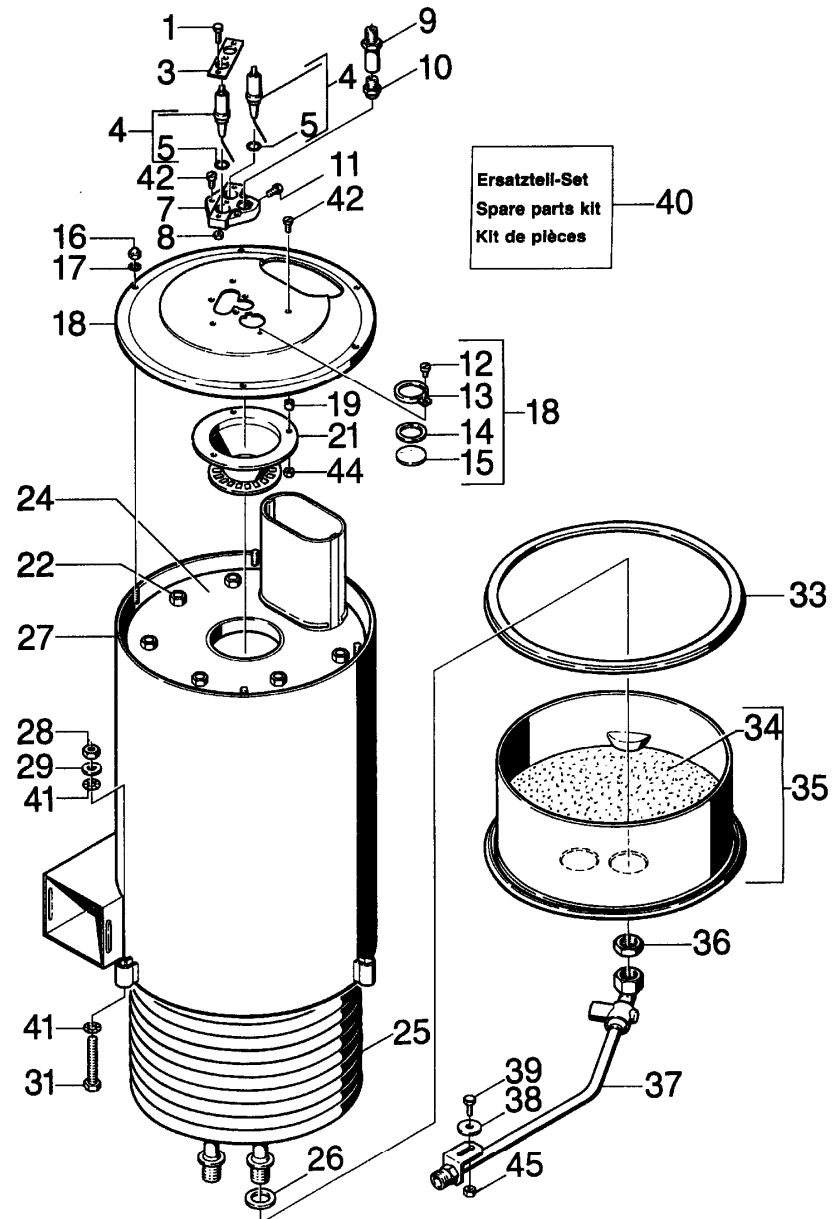

Symbolbeschreibung siehe M16 / symbol description see M16 / désignation de système voir M16 /

GRUPPE: 7.0 DURCHLAUFERHITZER
 GROUP: 7.0 FLOW HEATER
 GROUPE: 7.0 CHAUFFE-EAU RAPIDE

C7

HDS 580/610

POS. ITM. POS.	BENNENNUNG DESCRIPTION DESIGNATION	TEILE-NR. PART-NO. NO.PIECE	STCK QTY. NBR.	POS. ITM. POS.	BENNENNUNG DESCRIPTION DESIGNATION	TEILE-NR. PART-NO. NO.PIECE	STCK QTY. NBR.
1	6KT-SCHR. M 5X 16 / HEXAGONAL HEAD SCREW / VIS HEXAGONAL	7.304-372.0	3	39	SCHRAUBE M 6X 16 / SCREW / VIS	7.306-090.0	2
3	LASCHE / RETAINER CLIP / ECLISSE	5.004-228.0	1	40	ERSATZTEILSET / SPARE PARTS KIT / KIT DE PIECES	2.880-345.0	1
4	ERSATZTEILSET / SPARE PARTS KIT / KIT DE PIECES	2.880-177.0	1	41	ZAHNSCHEIBE A 10,5 / LOCK WASHER / ROUE PLATE	7.312-160.0	2
5	DICHTRING 12 X15,5 / JOINT RING / BAGUE D'ETANCHEITE	7.362-004.0	2	42	ZYL.SCHR. M 5X 12 / CHEESE HEAD SCREW / VIS A TETE CYLINDR.	7.306-443.0	6
7	KERZENHALTER / SPARK HOLDER / SUPPORT BOUGIE	5.668-001.0	1	44	6KT-MUTTER M 5 / HEXAGON NUT / ECROU HEXAGONAL	7.311-002.0	3
8	6KT-MUTTER M 5 / HEXAGON NUT / ECROU HEXAGONAL	7.311-037.0	3				
9	DUESENHALTER / NOZZLE HOLDER / PORTE - BUSE	5.667-021.0	1				
10	DUESE 1,35 60G H / NOZZLE / BUSE	6.415-001.0	1				
	/ 1.618-111.0 / -291.0						
10	DUESE 1,2 60G H / NOZZLE / BUSE	6.415-100.0	1				
	/ 1.608-121.0 / -291.0						
11	SCHRAUBE M 5X 12 / SCREW / VIS	7.306-076.0	7				
12	BL.SCHR. ST3,5X 6,5 / SHEET METAL SCREW / VIS A TOLE	7.303-012.0	1				
13	BLECH / PLATE / TOLE	5.000-590.0	1				
14	FLACHDICHTUNG / SEAL / GARNITURE PLATE	5.364-100.0	1				
15	GLASSCHEIBE / GLASS PANE / VITRE	6.278-014.0	1				
16	HUTMUTTER M 6 / CAP NUT / ECROU BORGNE	7.311-380.0	3				
17	ZAHNSCHEIBE A 6,4 / LOCK WASHER / ROUE PLATE	7.312-167.0	2				
18	DECKEL D.K. / COVER / COUVERCLE	4.654-091.0	1				
19	HUELSE / SLEEVE / DOUILLE	5.110-315.0	3				
21	BRENNEREINSATZ / BURNER CAGE / BRULEUR CAGE	4.663-060.0	1				
22	6KT-MUTTER M 6 / HEXAGON NUT / ECROU HEXAGONAL	7.311-039.0	4				
24	BRENNEREINSATZ / BURNER CAGE / BRULEUR CAGE	4.663-057.0	1				
25	HEIZSCHLANGE / HEATING COIL / SERPENTIN	4.680-062.0	1				
26	PROFILDICHTUNG / SEAL / ETOUPE PROFILE	5.365-068.0	1				
27	AUSSENMANTEL / OUTER JACKET / ENVELOPPE	4.652-055.0	1				
28	6KT-MUTTER M10 / HEXAGON NUT / ECROU HEXAGONAL	7.311-511.0	3				
29	SCHEIBE 10 / WASHER / RONDELLE	7.312-005.0	3				
31	6KT-SCHR. M10X 65 / HEXAGONAL HEAD SCREW / VIS HEXAGONAL	7.304-422.0	3				
32	ZARGE / FRAME / HUISSIERE	5.012-202.0	1				
33	DICHTSCHNUR / SEAL STRING / CORDE DE BOURRAGE	6.366-009.0	1				
34	STAMPFMASSE 8KG / REFRACTORY MATERIAL / PISE REFRACT. DAME	2.889-061.0	8				
35	BODEN D.K. / BOTTOM / FOND	4.655-036.0	1				
36	6KT-MUTTER M22X1,5 / HEXAGON NUT / ECROU HEXAGONAL	7.311-155.0	2				
37	ROHRLEITUNG / PIPELINES / CONDUITE	4.420-910.0	1				
38	UNTERLAGE / SPACER / COUSSINET	5.378-058.0	1				

"=> xxxxxx" = bis Werknummer / up to serial No. / jusqu' au No. de fabr. / "xxxxxx =>" = ab Werknummer / from serial No. / a partir du No. de fabr. /

GRUPPE: 8.0 SCHWIMMERKASTEN
GROUP: 8.0 FLOAT CHEST
GRUPPE: 8.0 BOITE DU FLOTTEUR

A8

HDS 580/610

GRUPPE: 8.0 SCHWIMMERKASTEN
GROUP: 8.0 FLOAT CHEST
GRUPPE: 8.0 BOITE DU FLOTTEUR

GRUPPE: 8.1 SCHWIMMERKASTEN / (1.618-291/-111) /
GROUP: 8.1 FLOAT CHEST / (1.618-291/-111) /
GRUPPE: 8.1 BOITE DU FLOTTEUR / (1.618-291/-111) /

B8

HDS 580/610

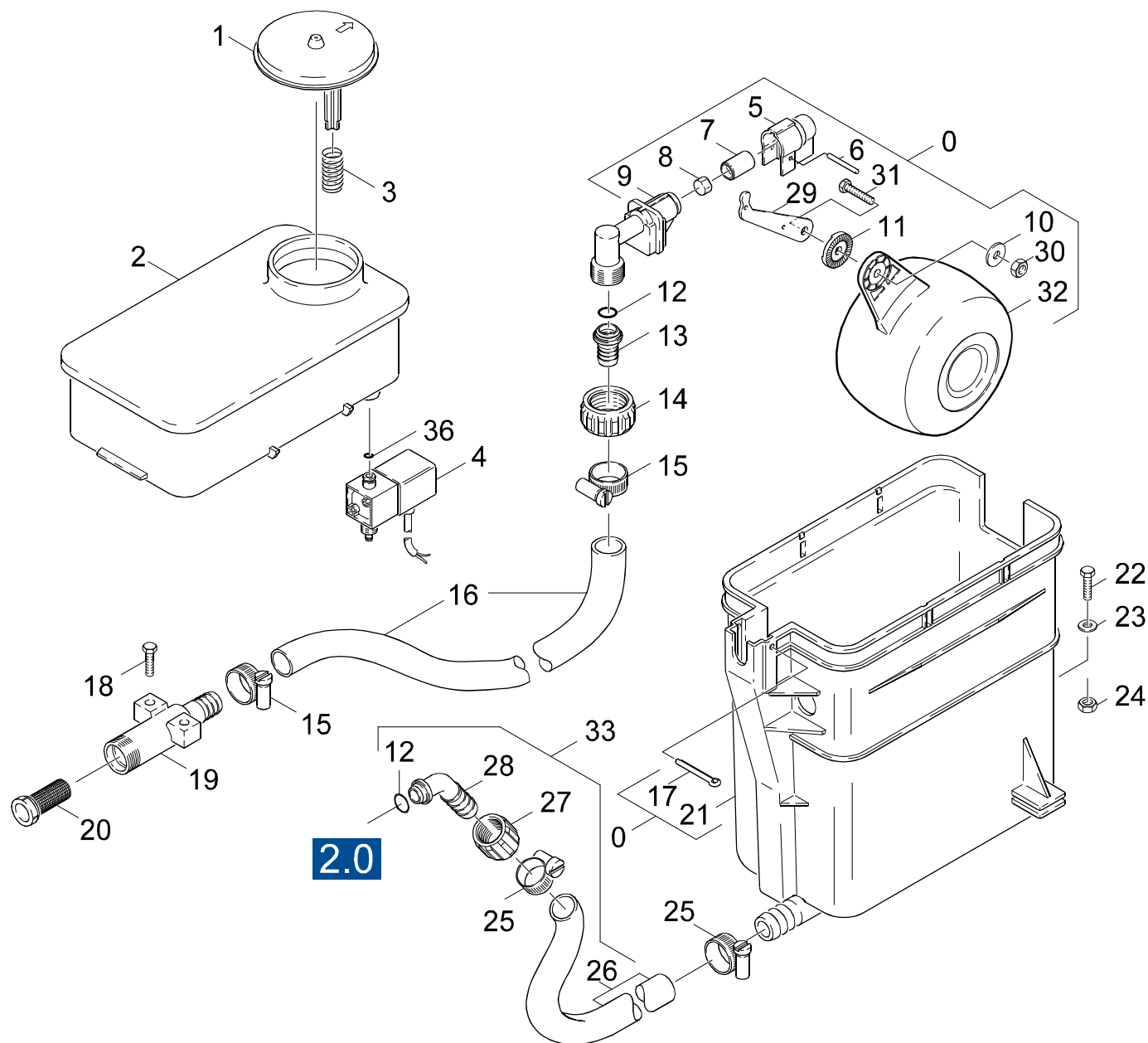

Symbolbeschreibung siehe M16 / symbol description see M16 / désignation de système voir M16 /

GRUPPE: 8.1 SCHWIMMERKASTEN / (1.618-291/-111) /
 GROUP: 8.1 FLOAT CHEST / (1.618-291/-111) /
 GROUPE: 8.1 BOITE DU FLOTTEUR / (1.618-291/-111) /

C8

HDS 580/610

POS. ITM. POS.	BENNENUNG DESCRIPTION DESIGNATION	TEILE-NR. PART-NO. NO.PIECE	STCK QTY. NBR.
0	SCHWIMMERVENTIL / FLOAT VALVE / SOUPAPE A FLOTTEUR	3.593-054.0	1
1	DECKEL / COVER / COUVERCLE	5.063-226.0	1
2	BEHAELTER / TANK / BAC	4.070-094.0	1
3	SCHRAUBENFEDER / HELICAL SPRING / RESSORT CYLINDRIQUE	5.332-001.0	1
4	MAGNETVENTIL / SOLENOID VALVE / ELECTROVANNE	6.685-210.0	1
5	SCHUTZTEIL / PROTECTION PART / PARTIE PROTECTEUR	5.394-066.0	1
6	BOLZEN 3,0X 25 / BOLT / BOULON	7.316-004.0	1
7	VENTILBOLZEN / VALVE PIN / BOULON DE SOUPAPE	5.584-026.0	1
8	FLACHDICHTUNG / SEAL / GARNITURE PLATE	5.364-095.0	1
9	VENTILGEHAEUSE / VALVE HOUSING / CORPS DE SOUPAPE	5.587-103.0	1
10	SCHEIBE 6 / WASHER / RONDELLE	7.312-279.0	1
11	SCHEIBE / WASHER / RONDELLE	5.115-158.0	1
12	O-RING 13,3 X 2,4 / GASKET / BAQUE D'ETANCHEITE	6.362-078.0	2
13	SCHLAUCHNIPPEL / HOSE STEM / RACCORD DE FLEXIBLE	5.443-224.0	1
14	MUTTER R 3/4Z / NUT / ECROU	5.310-061.0	1
15	SCHLAUCHSCHELLE / HOSE BAND CLIP / COLLIER DE SERRAGE	6.388-547.0	2
16	SCHLAUCH DN16 / HOSE / TUYAU FLEXIBLE	6.388-719.0	1
17	SPLINT 4,0X 50 / COTTER / GOUPILLE FENDUE	7.316-432.0	1
18	SCHRAUBE M 6X 16 / SCREW / VIS	7.306-090.0	1
19	KNOTENSTUECK / MANIFOLD / FERRURE NODALE	5.427-075.0	1
20	SIEB / STRAINER / CREPINE	6.414-141.0	1
21	BEHAELTER / TANK / BAC	5.070-064.0	1
22	BL.SCHR. ST4,8X25,0 / SHEET METAL SCREW / VIS A TOLE	7.303-364.0	2
23	SCHEIBE 5 / WASHER / RONDELLE	7.312-278.0	2
24	SCHNAPPMUTTER 4,8 / SNAP NUT / ECROU A ENCLANCH.	6.310-028.0	2
25	KABELBAND 8-210 / CABLE TIE / PROTECT. DE CABLE	6.641-474.0	2
26	SCHLAUCH 19X4X260 / HOSE / TUYAU FLEXIBLE	6.388-739.0	1
27	MUTTER / NUT / ECROU	5.310-062.0	1
28	SCHLAUCHNIPPEL / HOSE STEM / RACCORD DE FLEXIBLE	5.443-211.0	1
29	HEBEL / LEVER / LEVIER	5.481-029.0	1
30	6KT-MUTTER M 6 / HEXAGON NUT / ECROU HEXAGONAL	7.311-422.0	1
31	SCHRAUBE M 6X 20 / SCREW / VIS	7.306-194.0	1
32	SCHWIMMER / FLOAT / FLOTTEUR	5.585-004.0	1
33	SCHLAUCH / HOSE / TUYAU FLEXIBLE	4.440-271.0	1
36	O-RING 6,07X 1,78 / GASKET / BAQUE D'ETANCHEITE	6.362-176.0	1

"=> xxxxxx" = bis Werknummer / up to serial No. / jusqu' au No. de fabr. / "xxxxxx =>" = ab Werknummer / from serial No. / a partir du No. de fabr. /

GRUPPE: 8.2 SCHWIMMERKASTEN / (1.608-291/-121) /
 GROUP: 8.2 FLOAT CHEST / (1.608-291/-121) /
 GROUPE: 8.2 BOITE DU FLOTTEUR / (1.608-291/-121) /

E8

HDS 580/610

POS. ITM. POS.	BENNENUNG DESCRIPTION DESIGNATION	TEILE-NR. PART-NO. NO.PIECE	STCK QTY. NBR.
0	SCHWIMMERVENTIL / FLOAT VALVE / SOUPAPE A FLOTTEUR	3.593-054.0	1
1	DECKEL / COVER / COUVERCLE	5.063-226.0	1
2	BEHAELTER / TANK / BAC	4.070-094.0	1
3	SCHRAUBENFEDER / HELICAL SPRING / RESSORT CYLINDRIQUE	5.332-001.0	1
4	MAGNETVENTIL / SOLENOID VALVE / ELECTROVANNE	6.685-210.0	1
5	SCHUTZTEIL / PROTECTION PART / PARTIE PROTECTEUR	5.394-066.0	1
6	BOLZEN 3,0X 25 / BOLT / BOULON	7.316-004.0	1
7	VENTILBOLZEN / VALVE PIN / BOULON DE SOUPAPE	5.584-026.0	1
8	FLACHDICHTUNG / SEAL / GARNITURE PLATE	5.364-095.0	1
9	VENTILGEHAEUSE / VALVE HOUSING / CORPS DE SOUPAPE	5.587-103.0	1
10	SCHEIBE 6 / WASHER / RONDELLE	7.312-279.0	1
11	SCHEIBE / WASHER / RONDELLE	5.115-158.0	1
12	O-RING 13,3 X 2,4 / GASKET / BAQUE D'ETANCHEITE	6.362-078.0	2
13	SCHLAUCHNIPPEL / HOSE STEM / RACCORD DE FLEXIBLE	5.443-224.0	1
14	MUTTER R 3/4Z / NUT / ECROU	5.310-061.0	1
15	SCHLAUCHSCHELLE / HOSE BAND CLIP / COLLIER DE SERRAGE	6.388-547.0	2
16	SCHLAUCH DN16 / HOSE / TUYAU FLEXIBLE	6.388-719.0	1
17	SPLINT 4,0X 50 / COTTER / GOUPILLE FENDUE	7.316-432.0	1
18	SCHRAUBE M 6X 16 / SCREW / VIS	7.306-090.0	1
19	KNOTENSTUECK / MANIFOLD / FERRURE NODALE	5.427-075.0	1
20	SIEB / STRAINER / CREPINE	6.414-141.0	1
21	BEHAELTER / TANK / BAC	5.070-064.0	1
22	BL.SCHR. ST4,8X25,0 / SHEET METAL SCREW / VIS A TOLE	7.303-364.0	2
23	SCHEIBE 5 / WASHER / RONDELLE	7.312-278.0	2
24	SCHNAPPMUTTER 4,8 / SNAP NUT / ECROU A ENCLANCH.	6.310-028.0	2
25	KABELBAND 8-210 / CABLE TIE / PROTECT. DE CABLE	6.641-474.0	2
26	SCHLAUCH 19X4X260 / HOSE / TUYAU FLEXIBLE	6.388-739.0	1
27	MUTTER / NUT / ECROU	5.310-062.0	1
28	SCHLAUCHNIPPEL / HOSE STEM / RACCORD DE FLEXIBLE	5.443-211.0	1
29	HEBEL / LEVER / LEVIER	5.481-029.0	1
30	6KT-MUTTER M 6 / HEXAGON NUT / ECROU HEXAGONAL	7.311-422.0	1
31	SCHRAUBE M 6X 20 / SCREW / VIS	7.306-194.0	1
32	SCHWIMMER / FLOAT / FLOTTEUR	5.585-004.0	1
33	SCHLAUCH / HOSE / TUYAU FLEXIBLE	4.440-271.0	1
34	BUCHSE / BUSH / DOUILLE	5.112-189.0	1
36	O-RING 6,07X 1,78 / GASKET / BAQUE D'ETANCHEITE	6.362-176.0	1

"=> xxxxxx" = bis Werknummer / up to serial No. / jusqu' au No. de fabr. / "xxxxxx =>" = ab Werknummer / from serial No. / a partir du No. de fabr. /

GRUPPE: 9.0 SICHERHEITSBLOCK
GROUP: 9.0 SAFETY SYSTEM
GRUPPE: 9.0 BLOC DE SECURITE

A9

HDS 580/610

GRUPPE: 9.0 SICHERHEITSBLOCK
GROUP: 9.0 SAFETY SYSTEM
GRUPPE: 9.0 BLOC DE SECURITE

GRUPPE: 9.0 SICHERHEITSBLOCK
 GROUP: 9.0 SAFETY SYSTEM
 GROUPE: 9.0 BLOC DE SECURITE

C9

HDS 580/610

POS. ITM. POS.	BENNENNUNG DESCRIPTION DESIGNATION	TEILE-NR. PART-NO. NO.PIECE	STCK QTY. NBR.	POS. ITM. POS.	BENNENNUNG DESCRIPTION DESIGNATION	TEILE-NR. PART-NO. NO.PIECE	STCK QTY. NBR.
0	SICHERHEITSBLOCK / SAFETY SYSTEM / BLOC DE SECURITE / 1.618-111.0 / -291.0	4.749-005.0	1	30	HD-SCHLAUCH DN 8 / HIGH PRESSURE HOSE / TUYAU FLEXIBLE HAUTE PRE.	6.388-859.0	1
0	SICHERHEITSBLOCK / SAFETY SYSTEM / BLOC DE SECURITE / 1.608-121.0 / -291.0	4.749-013.0	1	31	SIEB / STRAINER / CREPINE	6.414-111.0	1
1	SCHUTZTEIL / PROTECTION PART / PARTIE PROTECTEUR	5.394-060.0	1	32	O-RING 17,3 X 2,4 / GASKET / BAQUE D'ETANCHEITE	6.362-160.0	1
2	SCHRAUBE M 3X 16 / SCREW / VIS	7.306-054.0	1	33	VERSCHLUSSCHRAUBE / CLOSING SCREW / VIS DE FERMETURE	5.411-059.0	1
3	6KT-MUTTER M 3 / HEXAGON NUT / ECROU HEXAGONAL	7.311-000.0	3	34	HALTER / BRACKET / FIXATION	5.042-261.0	1
4	6KT-SCHR. M 3X 20 / HEXAGONAL HEAD SCREW / VIS HEXAGONAL	7.304-352.0	2	35	6KT-MUTTER M22X1,5 / HEXAGON NUT / ECROU HEXAGONAL	7.311-155.0	1
6	MIKROSCHALTER / MICRO SWITCH / MICRORUPTEUR	6.631-125.0	1	36	ROHRLEITUNG / PIPELINES / CONDUITE	4.420-912.0	1
7	FEDERRING B 3 / SPRING WASHER / RONDELLE GROWER	7.313-000.0	2				
8	GEHAEUSE / HOUSING / BOITIER	5.060-099.0	1				
9	SCHRAUBE M 6X 30 / SCREW / VIS	7.306-105.0	2				
10	KOLBEN / PISTON / PISTON	5.553-046.0	1				
11	O-RING 12,0 X 2,0 / GASKET / BAQUE D'ETANCHEITE	6.362-169.0	1				
12	BUCHSE / BUSH / DOUILLE / 1.618-111.0 / -291.0	5.112-093.0	1				
12	BUCHSE / BUSH / DOUILLE / 1.608-121.0 / -291.0	5.112-113.0	1				
13	SCHRAUBENFEDER / HELICAL SPRING / RESSORT CYLINDRIQUE	5.332-069.0	1				
14	SCHRAUBENFEDER / HELICAL SPRING / RESSORT CYLINDRIQUE	5.332-070.0	1				
15	STANGE / BAR / TIGE	5.107-023.0	1				
16	BUCHSE / BUSH / DOUILLE	5.112-094.0	1				
17	S-SCHEIBE 4 / LOCK WASHER / RONDELLE D'ARRET	7.343-203.0	1				
18	SCHEIBE / WASHER / RONDELLE	5.115-147.0	1				
19	KOLBEN / PISTON / PISTON	4.553-025.0	1				
20	SCHRAUBE M 6X 16 / SCREW / VIS	7.306-090.0	1				
22	ERSATZREEDSCHALTER / SPARE REED SWITCH / INTERRUPT.REED DE RESERVE	2.880-194.0	1				
23	FORMSCHRAUBE / SCREW / VIS	5.305-162.0	1				
24	O-RING 10 X 1,5 / GASKET / BAQUE D'ETANCHEITE	6.362-482.0	1				
25	SCHRAUBENFEDER / HELICAL SPRING / RESSORT CYLINDRIQUE	5.332-057.0	1				
26	KOLBEN / PISTON / PISTON	4.553-022.0	1				
27	GEHAEUSE / HOUSING / BOITIER	5.605-131.0	1				
28	DICHTRING 18 X22 / JOINT RING / BAGUE D'ETANCHEITE	7.362-009.0	1				
29	STUTZEN 12 / CONNECTION PIECE / TUBULURE	7.386-126.0	1				

"=> xxxxxx" = bis Werknummer / up to serial No. / jusqu' au No. de fabr. / "xxxxxx =>" = ab Werknummer / from serial No. / a partir du No. de fabr. /

GRUPPE: 10.0ZUBEHOER
GROUP: 10.0ACCESSORIES
GRUPPE: 10.0ACCESSOIRES

A10

HDS 580/610

GRUPPE: 10.0ZUBEHOER
GROUP: 10.0ACCESSORIES
GRUPPE: 10.0ACCESSOIRES

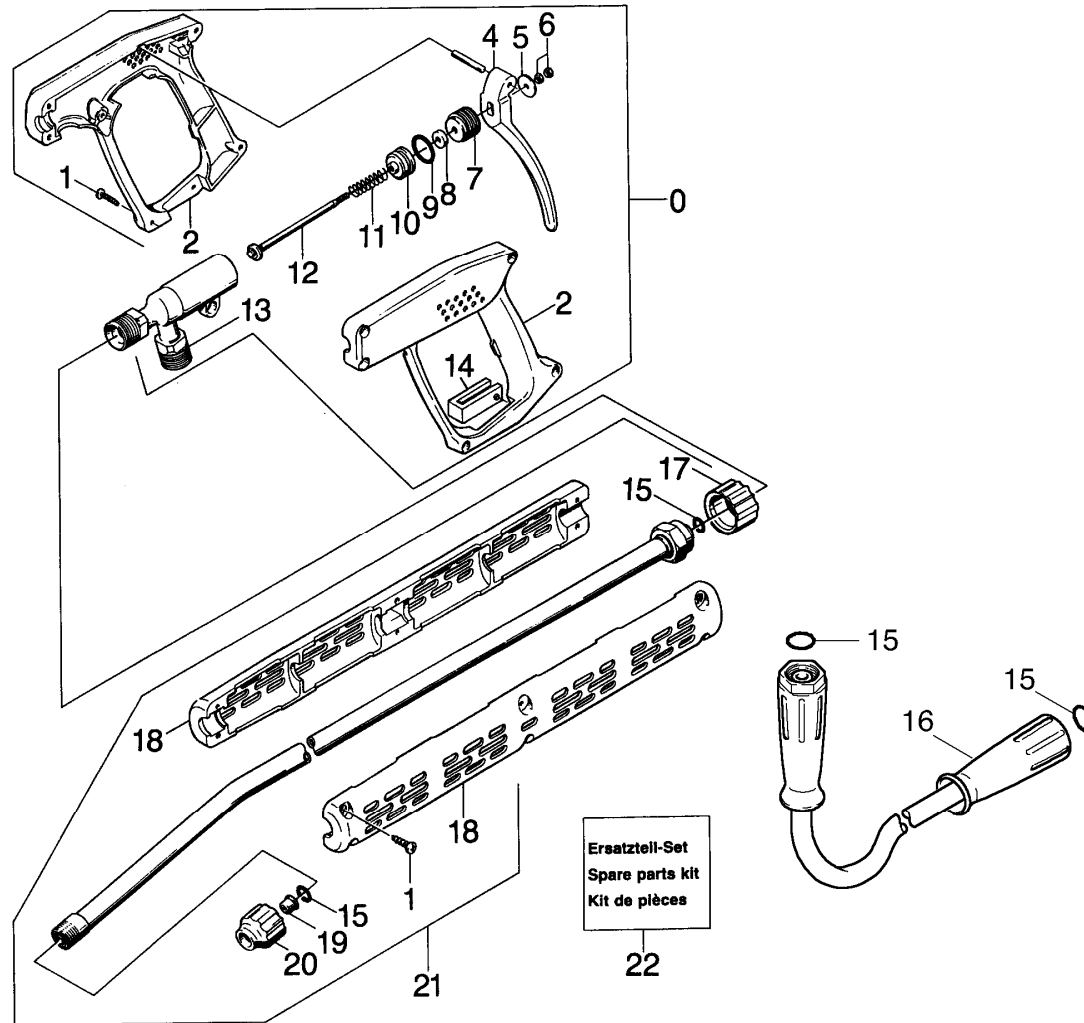

Symbolbeschreibung siehe M16 / symbol description see M16 / désignation de système voir M16 /

GRUPPE: 10.0ZUBEHOER
GROUP: 10.0ACCESSORIES
GROUPE: 10.0ACCESSOIRES

C10

HDS 580/610

POS. ITM. POS.	BENNENUNG DESCRIPTION DESIGNATION	TEILE-NR. PART-NO. NO.PIECE	STCK QTY. NBR.
0	HANDSPRITZPISTOLE / TRIGGER GUN / POIGNEE PISTOLET	4.775-012.0	1
1	LINSENSCHR. 4,2X16 / OVAL HEAD SCREW / VIS A TETE BOMBEE	6.303-025.0	6
2	GRIFFPAAR / HANDLES / BRANCHES POIGNEE	5.321-052.0	1
4	HEBEL / LEVER / LEVIER	5.481-026.0	1
5	SCHEIBE / WASHER / RONDELLE	5.115-187.0	1
6	6KT-MUTTER M 4 / HEXAGON NUT / ECROU HEXAGONAL	7.311-036.0	2
7	FORMSCHRAUBE / SCREW / VIS	5.305-075.0	1
8	LIPPENRING / LIP RING / JOINT A LEVRE	6.365-041.0	1
9	O-RING 15,0 X 2,5 / GASKET / BAQUE D'ETANCHEITE	7.362-504.0	1
10	HUELSE / SLEEVE / DOUILLE	5.110-150.0	1
11	SCHRAUBENFEDER / HELICAL SPRING / RESSORT CYLINDRIQUE	5.332-050.0	1
12	VENTILSITZ / VALVE SEAT / SIEGE DE SOUPAPE	4.581-010.0	1
13	KNOTENSTUECK / MANIFOLD / FERRURE NODALE	5.427-029.0	1
14	HEBEL / LEVER / LEVIER	5.481-020.0	1
15	ERSATZTEILSET / SPARE PARTS KIT / KIT DE PIECES	2.880-296.0	1
16	HD-SCHLAUCHLEITUNG / HIGH PRESSURE HOSE / CONDUITE HAUTE PERSSION	6.388-083.0	1
17	SCHUTZTEIL / PROTECTION PART / PARTIE PROTECTEUR	5.394-050.0	1
18	GRIFF / HANDLE / POIGNEE	5.321-102.0	2
19	DUES.MUNDST. 25G05 / NOZZLE MOUTHPIECE / NEZ DE BUSE	6.415-162.0	1
20	VERSCHRAUBUNGSTEIL / SCREW UNION PART / PIECE (RACCORD A VIS)	5.401-129.0	1
21	STRAHLROHR / JET PIPE / LANCE D'INCENDIE	4.760-049.0	1
22	ERSATZTEILSET / SPARE PARTS KIT / KIT DE PIECES	2.880-173.0	1

"=> xxxxxx" = bis Werknummer / up to serial No. / jusqu' au No. de fabr. / "xxxxxx =>" = ab Werknummer / from serial No. / a partir du No. de fabr. /

GRUPPE: 11.0 INSTRUMENTENTAFEL
GROUP: 11.0 CONTROL PANEL
GRUPPE: 11.0 TABLEAU DE BORD

A11

HDS 580/610

GRUPPE: 11.0 INSTRUMENTENTAFEL
GROUP: 11.0 CONTROL PANEL
GRUPPE: 11.0 TABLEAU DE BORD

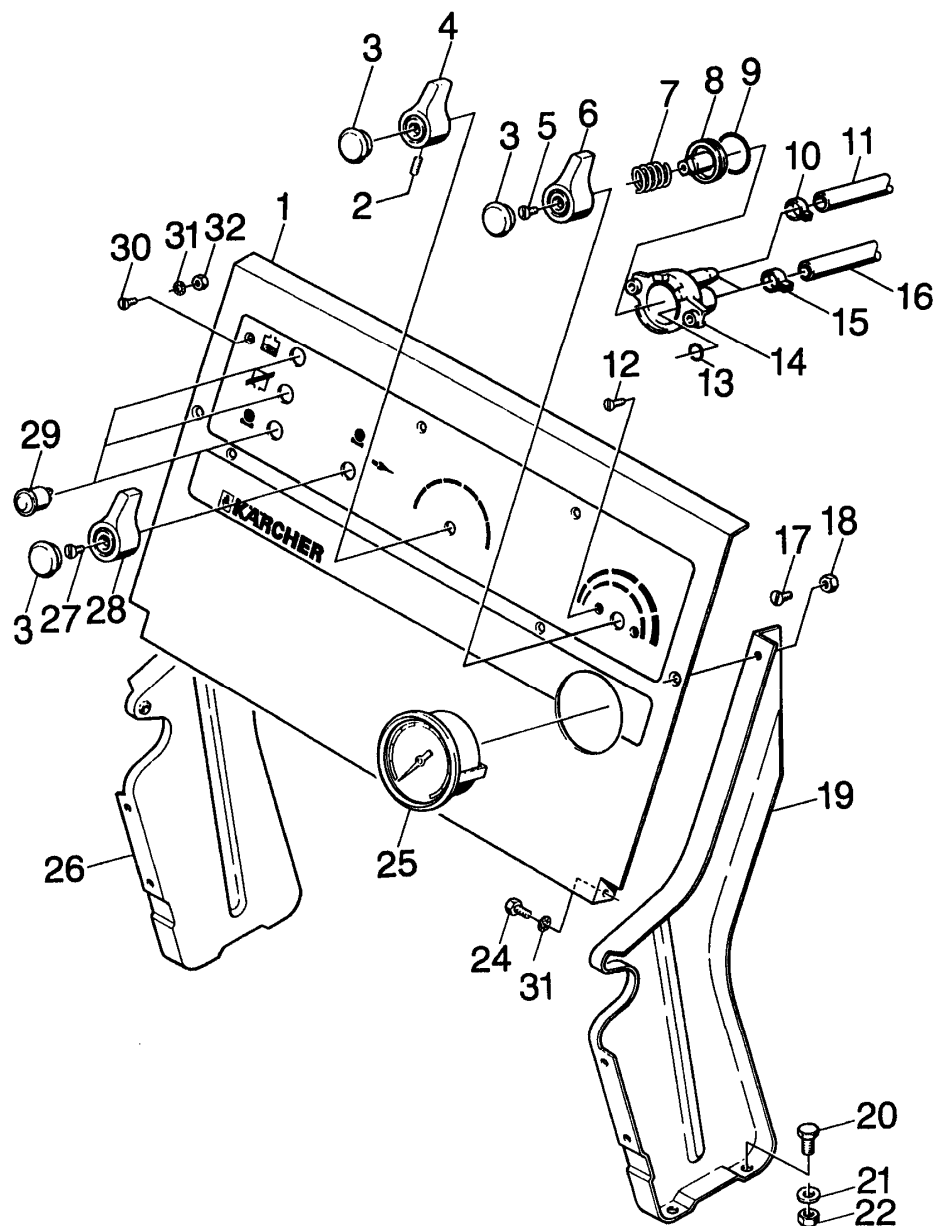

Symbolbeschreibung siehe M16 / symbol description see M16 / désignation de système voir M16 /

GRUPPE: 11.0 INSTRUMENTENTAFEL
 GROUP: 11.0 CONTROL PANEL
 GROUPE: 11.0 TABLEAU DE BORD

C11

HDS 580/610

POS. ITM. POS.	BENNENUNNG DESCRIPTION DESIGNATION	TEILE-NR. PART-NO. NO.PIECE	STCK QTY. NBR.	POS. ITM. POS.	BENNENUNNG DESCRIPTION DESIGNATION	TEILE-NR. PART-NO. NO.PIECE	STCK QTY. NBR.
1	INSTRUMENTENTAFEL / CONTROL PANEL / TABLEAU DE BORD VERSION 1 / 1.608-121.0 / -291.0	5.841-114.0	1	24	SCHRAUBE M 5X 10 / SCREW / VIS	7.306-071.0	2
1	INSTRUMENTENTAFEL / CONTROL PANEL / TABLEAU DE BORD VERSION 2 / 1.618-111.0 / -291.0	5.841-115.0	1	25	MANOMETER O-250 BAR / PRESSURE GAUGE / MANOMETRE	6.421-075.0	1
2	GEW.STIFT M 5X 10 / THREADED PIN / VIS SANS TETE	7.307-181.0	1	26	STAENDER LINKS / STAND / MONTANTS	5.052-012.0	1
3	STOPFEN / PLUG / BOUCHON	5.132-010.0	3	27	ZYL.SCHR. M 3,5X 12 / CHEESE HEAD SCREW / VIS A TETE CYLINDR.	7.306-415.0	1
4	GRIFF / HANDLE / POIGNEE	5.321-026.0	1	28	GRIFF / HANDLE / POIGNEE	5.321-021.0	1
5	SENKSCHR. M 4X 16 / FLAT HEADED SCREW / VIS A TETE CONIQUE	7.305-023.0	1	29	ANZEIGELEUCHTE / PILOT LAMP / LAMPE TEMOIN	6.651-058.0	3
6	GRIFF / HANDLE / POIGNEE	5.321-023.0	1	31	ZAHNSCHEIBE A 6,4 / LOCK WASHER / ROUE PLATE	7.312-165.0	12
7	SCHRAUBENFEDER / HELICAL SPRING / RESSORT CYLINDRIQUE	5.332-028.0	1	32	6KT-MUTTER M 4 / HEXAGON NUT / ECROU HEXAGONAL	7.311-424.0	5
8	VENTILSITZ / VALVE SEAT / SIEGE DE SOUPAPE	5.581-039.0	1				
9	O-RING 26,0 X 2,5 / GASKET / BAQUE D'ETANCHEITE	6.362-385.0	1				
10	SCHLAUCHSCHELLE / HOSE BAND CLIP / COLLIER DE SERRAGE	6.388-550.0	1				
11	SCHLAUCH DN 7 / HOSE / TUYAU FLEXIBLE ALS METERWARE BESTELLEN/TO ORDER AS CUT GOODS/COMMANDE COMME MARCHANDISE AU METRE	6.388-194.0	1				
12	SENKSCHR. M 4X 10 / FLAT HEADED SCREW / VIS A TETE CONIQUE	6.305-001.0	7				
13	O-RING 5 X 1,5 / GASKET / BAQUE D'ETANCHEITE	6.362-386.0	1				
14	VENTILGEHAEUSE / VALVE HOUSING / CORPS DE SOUPAPE	5.587-054.0	1				
15	SCHLAUCHSCHELLE / HOSE BAND CLIP / COLLIER DE SERRAGE	6.388-559.0	2				
16	SCHLAUCH DN 7 / HOSE / TUYAU FLEXIBLE ALS METERWARE BESTELLEN/TO ORDER AS CUT GOODS/COMMANDE COMME MARCHANDISE AU METRE	6.388-225.0	2				
17	SENKSCHR. M 5X 10 / FLAT HEADED SCREW / VIS A TETE CONIQUE	7.305-599.0	2				
18	6KT-MUTTER M 5 / HEXAGON NUT / ECROU HEXAGONAL	7.311-421.0	4				
19	STAENDER RECHTS / STAND / MONTANTS	5.052-013.0	1				
20	6KT-SCHR. M 8X 16 / HEXAGONAL HEAD SCREW / VIS HEXAGONAL	7.304-395.0	8				
21	SCHEIBE 8 / WASHER / RONDELLE	7.312-004.0	8				
22	6KT-MUTTER M 8 / HEXAGON NUT / ECROU HEXAGONAL	7.311-004.0	8				

"=> xxxxxx" = bis Werknummer / up to serial No. / jusqu' au No. de fabr. / "xxxxxx =>" = ab Werknummer / from serial No. / a partir du No. de fabr. /

Bestellhinweis

Bei Ihrer Bestellung sind unbedingt anzugeben :

1.	2.	3.	4.	5.
Gerätetyp Machine model Type d'appareils	Herstell-Nr. Serial-No. No. de série	Benennung Description Désignation	Teile-Nr. Part No. Référence	Stückzahl Piece No. Quantité



**siehe Typenschild
see name-plate
voir plaque signalétique**



**siehe Ersatzteilliste
see spare parts list
voir liste des pièces de rechange**

- Die Ersatzteile, welche als Meterware geliefert werden, sind auf Einbaulänge selbst zu kürzen. Ebenso sind die Stückzahlen in den jeweiligen Gruppen als Mindestbestellmengen = 1m angegeben und können je nach Bedarf auf weitere volle Meterzahlen erhöht und bestellt werden.
- Spare Parts which are delivered as cut goods have to be shortened to installation length. The quotation of quantity in each group refers to the minimum order quantity = 1m and may be ordered and raised to further full metre-values according to demand
- Les pièces de rechange qui sont livrées comme marchandise au mètre sont à raccourcir selon la longueur d'installation. Les indications de quantité dans chaque group se réfèrent à des valeurs de mètre de plus.
- Diese Ersatzteilliste erscheint in gedruckter Form sowie als Mikrofiche. Bei Querverweisen bezieht sich die Angabe "Seitenzahl" auf die gedruckte Ersatzteilliste und die Angabe "Bildtafel" auf die Mikrofilmausgabe.
- This spare parts list is published both in printed form and as a microfiche. In the cross-references, "page number" refers to the printed spare parts list and "display table" to the microfilm edition.
- Cette liste de pièces de rechange est aussi bien imprimée que publiée sous forme de microfiche. Les indications transversales renvoient au "numéro de page" sur la liste imprimée des pièces de rechange et à la "planche" sur la microfiche.

Bitte beachten Sie, daß der Teileumfang dieser Ersatzteilliste nicht unbedingt dem Lieferumfang Ihres Geräte entspricht.

For your information: It could be that certain parts quoted in this spare parts list were not included with the machine delivery.

Pour votre information: il se peut que certaines pièces détachées mentionnées sur la liste ne vous aient pas été livrées avec l'appareil.

Die in dieser Ersatzteilliste nicht aufgeführten Einzelteile, bestellen Sie bitte direkt beim Vertragskundendienst des jeweiligen Herstellers.

Please order the individual parts not included in this assembly directly with the contract aftersales service of the manufacturer in question.

Veillez s'il vous plaît, commander les pièces détachées qui ne sont indiquées dans notre liste des pièces détachées, directement auprès du service après-vente des fabricants en question.

Bei Bestellung von lackierten Teilen, welche in der Ersatzteilliste nicht in verschiedenen Farben ausgewiesen sind, ist zusätzlich die Farbnummer oder Farbe mit anzugeben. Diese finden Sie auf dem Typenschild oder Farbschild Ihres Gerätes.

Upon ordering of varnished parts which are not mentioned in the spare parts list as parts with different colors, kindly additionally mention the number of the color. It can be seen on the type plate of the color plate of your machine.

Commandant des parts vernissés qui ne sont pas mentionnés comme parts avec une couleur différente dans la liste des pièces détachées, veuillez mentionner de plus le numéro de la couleur. Il se trouve sur la plaque signalétique ou la plaque de couleur de votre machine.

Auflistungen von Einzelteilen bei Ersatzteil - u. Pumpensets sind in der Reihe "16" einzusehen, bzw. direkt unter dem entsprechenden Set aufgelistet.

Listings of single parts upon spare parts kits and pump kits can be seen in row "16" or directly listed below the corresponding kit.
Des établissements des pièces détachées en ce qui concerne les kits des pièces de rechange et les kits de pompes, peuvent être vus à la ligne "16" ou ils sont répertoriés directement au-dessous du jeu correspondant.

Technische Änderungen im Rahmen der Weiterentwicklung sowie das Recht der ausschließlichen Auswertung unseres geistigen Eigentums behalten wir uns vor. Vervielfältigung und Nachdruck nur mit Genehmigung und Urheberhinweis möglich.

We reserve the right to make technical changes in the course of development work and the right to make exclusive use of our intellectual property. This spare parts list may be duplicated or reprinted only with our approval and with acknowledgement of our copyright.

Nous nous réservons le droit de toutes modifications techniques dans le cadre du perfectionnement des mises au point ainsi que le droit de la mise en valeur exclusive de notre propriété intellectuelle. Polycopie et reproduction exclusivement après accord et avec mention de l'auteur.

INDEX

M16

HDS 580/610

GRUPPE: 1.0 EINZELTEILE GROUP: 1.0 PIECE PARTS GROUPE: 1.0 PIECES CONSTITUANTES	A1-C1	GRUPPE: 9.0 SICHERHEITSBLOCK GROUP: 9.0 SAFETY SYSTEM GROUPE: 9.0 BLOC DE SECURITE	A9-C9
GRUPPE: 2.0 PUMPENSATZ GROUP: 2.0 PUMP SET GROUPE: 2.0 JEU (ENSEMBLE) DE POMPE	A2-E2	GRUPPE: 10.0 ZUBEHOER GROUP: 10.0 ACCESSORIES GROUPE: 10.0 ACCESSOIRES	A10-C10
GRUPPE: 3.0 MOTOR GROUP: 3.0 MOTOR GROUPE: 3.0 MOTEUR	A3-E3	GRUPPE: 11.0 INSTRUMENTENTAFEL GROUP: 11.0 CONTROL PANEL GROUPE: 11.0 TABLEAU DE BORD	A11-C11
GRUPPE: 4.0 GEBLAESE GROUP: 4.0 BLOWER GROUPE: 4.0 VENTILATEUR	A4-C4		
GRUPPE: 5.0 BRENNSTOFFPUMPE GROUP: 5.0 FUEL PUMP GROUPE: 5.0 POMPE DE COMBUSTIBLE	A5-C5		
GRUPPE: 6.0 E-GERAETESCHRANK GROUP: 6.0 ELECTRIC CONTROL BOX GROUPE: 6.0 COFFRET ELECTRIQUE	A6-C6		
GRUPPE: 7.0 DURCHLAUFERHITZER GROUP: 7.0 FLOW HEATER GROUPE: 7.0 CHAUFFE-EAU RAPIDE	A7-C7		
GRUPPE: 8.0 SCHWIMMERKASTEN GROUP: 8.0 FLOAT CHEST GROUPE: 8.0 BOITE DU FLOTTEUR	A8-E8		



BEISPIEL: VERSION 1
EXAMPLE: VERSION 1
EXEMPLE: VERSION 1

3.0

BEISPIEL: SIEHE IN GRUPPE 3
EXAMPLE: SEE IN GROUP 3
EXEMPLE: VOIR EN GROUPE 3



WICHTIGER HINWEIS
IMPORTANT REMARK
REMARQUAGE IMPORTANT

GRUPPE 1-16 = MIKROFILM 1 GRUPPE 17-32 = MIKROFILM 2
GROUP 1-16 = MICROFICHE 1 GROUP 17-32 = MICROFICHE 2
GROUPE 1-16 = MICROFICHE 1 GROUPE 17-32 = MICROFICHE 2

BESTELLHINWEIS SIEHE M15
EXAMPLE ORDER SEE M15
EXEMPLE DE COMMANDE VOIR M15

VARIANTENÜBERSICHT SIEHE L16
VARIANTS SURVEY SEE L16
VUE D'ENSEMBLE DE VARIANTS VOIR L16