

Ersatzteilliste
Spare Parts List
Liste des pièces de rechange

VAP K 1701

1.995-120.0	K 1701-O.BE	*EUR
1.995-280.0	VAP K 1701-O.B	* GB
1.995-290.0	K 1701-O.BE	* CH
1.995-350.0	VAP K 1701-O.B	* DK
1.995-400.0	K 1701 -O.BE	*EUR
1.995-401.0	K 1701 -O.BE	* CH
1.995-402.0	K 1701 -M.BE	*EUR
1.995-403.0	K 1701 -M.BE	* CH
1.995-900.0	K 1701-M.BE	*EUR
1.995-901.0	K 1701-BE6000	* EUR
1.995-930.0	K 1701-M.BE	* CH
1.995-950.0	VAP K 1701-M.B	* DK

GRUPPE: 1.0 GERAET-EINZELTEILE
GROUP: 1.0 APPLIANCE - PIECE PARTS
GRUPPE: 1.0 USTENSILE-PIECES CONSTIT.

A1

VAP K 1701

GRUPPE: 1.0 GERAET-EINZELTEILE
GROUP: 1.0 APPLIANCE - PIECE PARTS
GRUPPE: 1.0 USTENSILE-PIECES CONSTIT.

GRUPPE: 1.1 GERAET-OBERTEIL
 GROUP: 1.1 APPLIANCE TOP PART
 GROUPE: 1.1 USTENSILE PARTIE SUPER.

B1

VAP K 1701

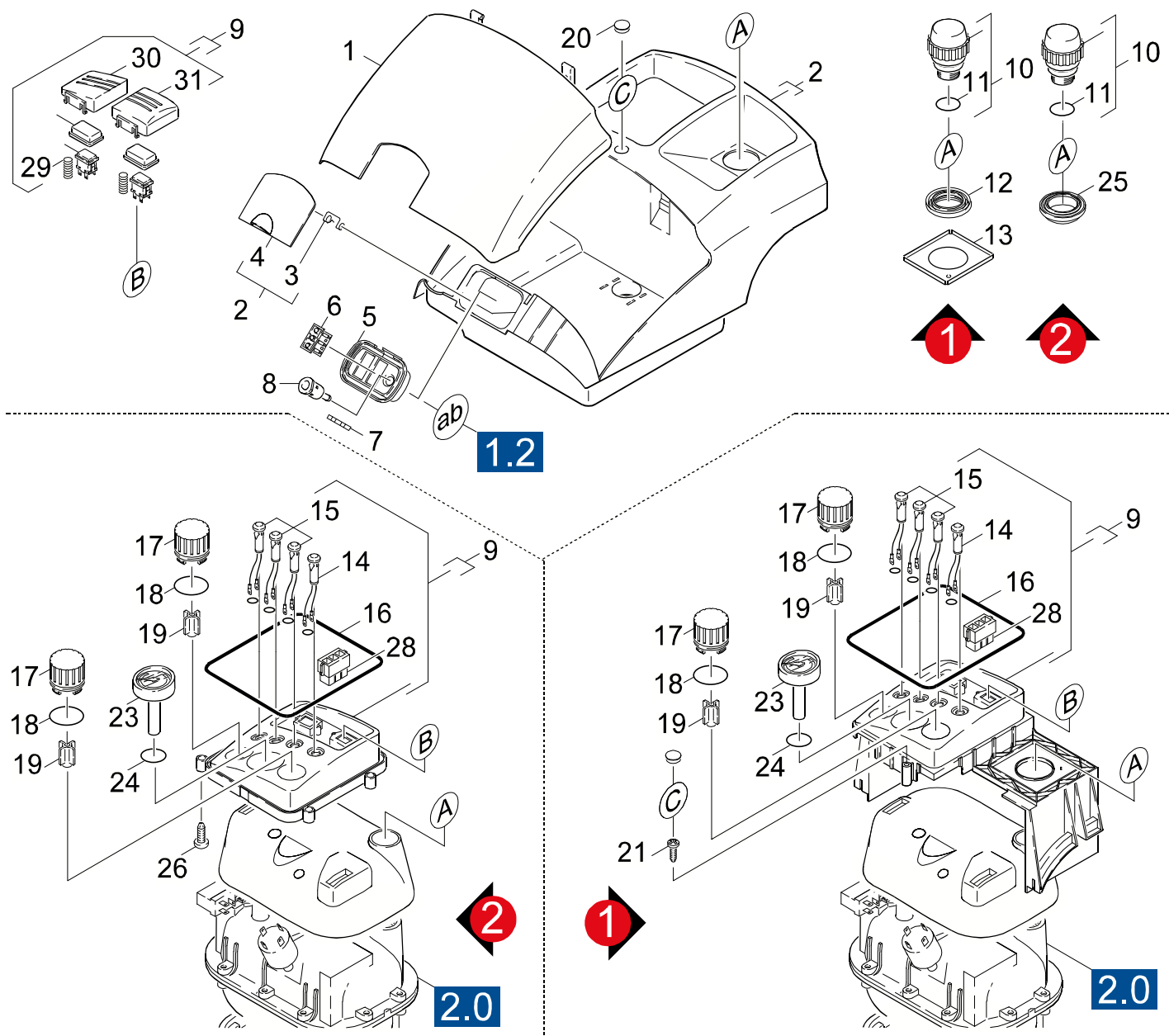

Symbolbeschreibung siehe M16 / symbol description see M16 / désignation de système voir M16 /

GRUPPE: 1.1 GERAET-OBERTEIL
 GROUP: 1.1 APPLIANCE TOP PART
 GROUPE: 1.1 USTENSILE PARTIE SUPER.

C1

VAP K 1701

POS. ITM. POS.	BENNENUNNG DESCRIPTION DESIGNATION	TEILE-NR. PART-NO. NO.PIECE	STCK QTY. NBR.	POS. ITM. POS.	BENNENUNNG DESCRIPTION DESIGNATION	TEILE-NR. PART-NO. NO.PIECE	STCK QTY. NBR.
1	HAUBE VAP K 1701 / COVER / CAPOT GRAU/GREY/GRIS	5.066-864.0	1	18	O-RING 24,0 X 2,0 / GASKET / BAQUE D'ETANCHEITE	6.362-522.0	2
1	HAUBE VAP K 1701 / COVER / CAPOT KORNGELBGELB/YELLOW/JAUNE	5.067-026.0	1	19	GRIFF -DREHKREUZ / HANDLE / POIGNEE	5.321-485.0	2
2	OBERTEIL M. DECKEL / TOP PART / PARTIE SUPERIEUR VERS.1 / => 231889GRAU/GREY/GRIS	4.066-236.0	1	20	ABDECKKAPPE / CAP / CHAPE GRAU/GREY/GRIS	5.031-196.0	1
2	OBERTEIL M. DECKEL / TOP PART / PARTIE SUPERIEUR VERS.1 KORNGELB / => 231889GELB/YELLOW/JAUNE	4.066-263.0	1	20	ABDECKKAPPE / CAP / CHAPE KORNGELBGELB/YELLOW/JAUNE	5.031-633.0	1
2	OBERTEIL M. DECKEL / TOP PART / PARTIE SUPERIEUR VERS.2 231890 =>	4.066-292.0	1	21	SCHRAUBE 5X25 / SCREW / VIS	6.303-200.0	1
2	OBERTEIL M. DECKEL / TOP PART / PARTIE SUPERIEUR KORNGELB VERS.2 231890 =>	4.066-323.0	1	23	THERMOMETER ZEIGER- / TEMPERATURE GAUGE / THERMOMETRE	6.423-064.0	1
3	DREHFEDER F.DECKEL / ROTATING SPRING / RESSORT A BRANCHES	5.332-343.0	1	24	O-RING 25,0 X 2,0 / GASKET / BAQUE D'ETANCHEITE	6.362-411.0	1
4	DECKEL / COVER / COUVERCLE GRAU/GREY/GRIS	5.063-620.0	1	25	DICHTUNG / SEAL / BOURRAGE	5.363-537.0	1
4	DECKEL / COVER / COUVERCLE KORNGELBGELB/YELLOW/JAUNE	5.063-823.0	1	VERS.2			
5	STECKDOSE / SOCKET / PRISE DE COURANT	5.031-262.0	1	26	SCHRAUBE 4 X 12 / SCREW / VIS	7.303-095.0	4
6	BUCHSENTEIL GERADE / BUSH PART / PIECE DE DOUILLE	6.600-105.0	2	VERS.2			
7	DICHTUNG / SEAL / BOURRAGE	5.363-364.0	1	28	GRUPPENSTECKER / CONNECTOR / GRUPPENSTECKER	6.647-657.0	1
8	NIPPEL / NIPPLE / NIPPLE	5.409-514.0	1	29	FEDER / SPRING / RESSORT	6.330-016.0	2
9	SCHALTKONSOLE KPL. / SWITCH DESK / PLAQUE D'INTERRUPT. VERS.2 2312890 =>	4.840-005.0	1	30	TASTER KLEIN / CALIPER / BOUTON POUSSOIR VERS.1 / => 231890	5.324-036.0	1
9	SCHALTKONSOLE KPL. / SWITCH DESK / PLAQUE D'INTERRUPT. VERS.1 / => 231890	4.840-021.0	1	30	TASTER KLEIN / CALIPER / BOUTON POUSSOIR VERS.2 231890 =>	5.324-049.0	1
10	SICHERHEITVERSCHL. / SAFETY LOCK / FERMETURE DE SURETE	4.590-075.0	1	31	TASTER GROSS / CALIPER / BOUTON POUSSOIR VERS.1 / => 231890	5.324-035.0	1
11	O-RING 21,89X 2,62 / GASKET / BAQUE D'ETANCHEITE	6.362-927.0	1	31	TASTER GROSS / CALIPER / BOUTON POUSSOIR VERS.2 231890 =>	5.324-048.0	1
12	DICHTUNG / SEAL / BOURRAGE VERS.1	5.363-371.0	1				
13	BLECHTEIL / PLATE / TOLE VERS.1	5.047-352.0	1				
14	SIGNALLEUCHTE ROT / PILOT LAMP / LAMPE TEMOIN	6.651-322.0	1				
15	SIGNALLEUCHTE GELB / PILOT LAMP / LAMPE TEMOIN	6.651-337.0	3				
16	DICHTUNG / SEAL / BOURRAGE	5.363-347.0	1				
17	GRIFF DREHKNOPF / HANDLE / POIGNEE	5.321-471.0	2				

"=> xxxxxx" = bis Werknummer / up to serial No. / jusqu' au No. de fabr. / "xxxxxx =>" = ab Werknummer / from serial No. / a partir du No. de fabr. /

GRUPPE: 1.2 GERAET-UNTERTEIL / VERS.1+2 /
GROUP: 1.2 APPLIANCE BOTTOM / VERS.1+2 /
GRUPPE: 1.2 USTENSILE PARTIE INFER. / VERS.1+2 /

D1

VAP K 1701

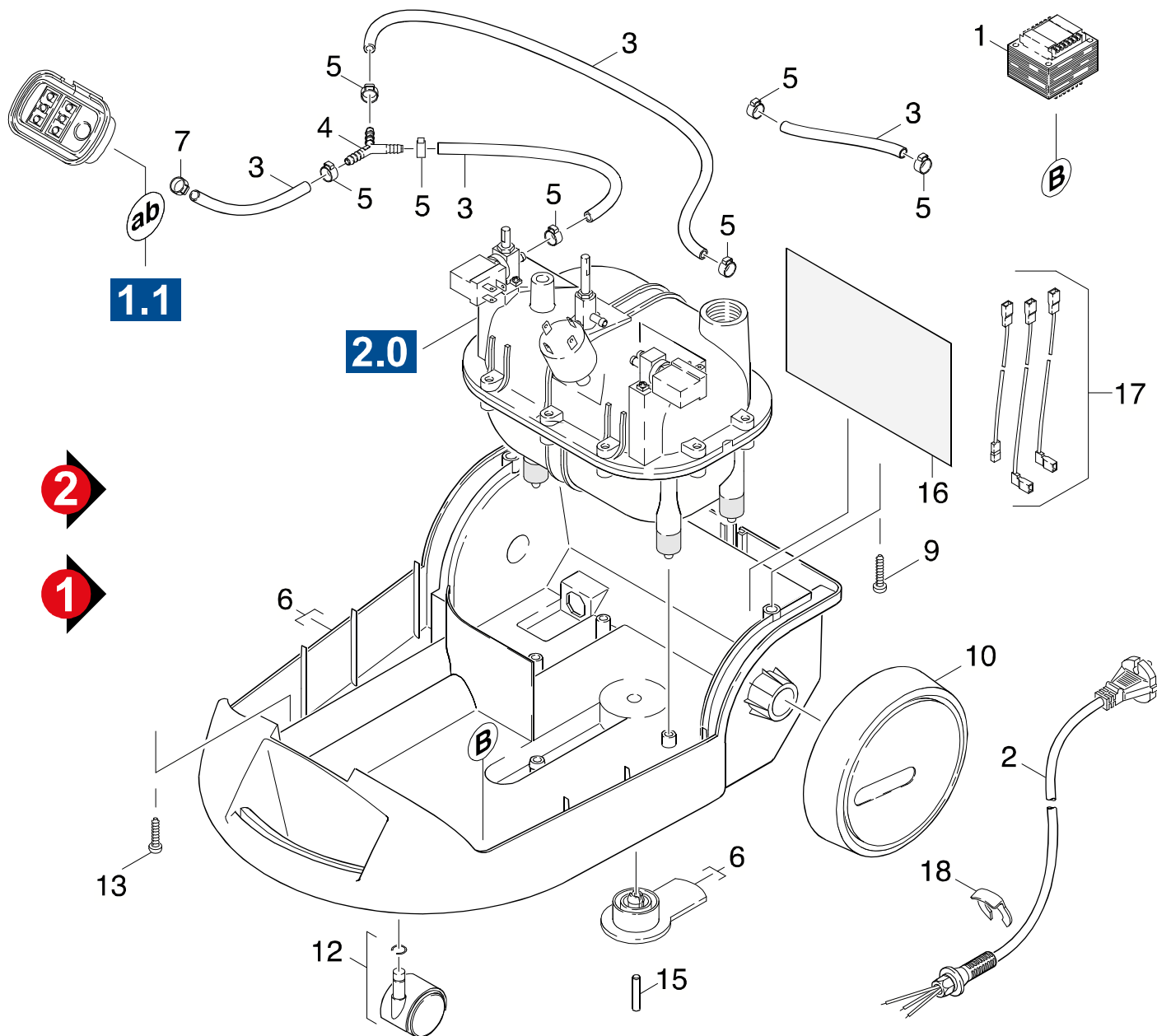

Symbolbeschreibung siehe M16 / symbol description see M16 / désignation de système voir M16 /

GRUPPE: 1.2 GERAET-UNTERTEIL / VERS.1+2 /
 GROUP: 1.2 APPLIANCE BOTTOM / VERS.1+2 /
 GROUPE: 1.2 USTENSILE PARTIE INFER. / VERS.1+2 /

E1

VAP K 1701

POS. ITM. POS.	BENNENUNG DESCRIPTION DESIGNATION	TEILE-NR. PART-NO. NO.PIECE	STCK QTY. NBR.
1	TRANSFORMATOR 10VA / TRANSFORMER / TRANSFORMATEUR	6.622-184.0	1
2	KABEL M.STECKER *EU / CABLE / CABLE / 1.995-120.0 / -400.0 / -402.0 / -900.0	6.647-498.0	1
2	KABEL M. STECKER *CH / CABLE / CABLE / 1.995-290.0 / -401.0 / -403.0 / -930.0	6.647-653.0	1
2	KABEL MIT STECKER / CABLE / CABLE / 1.995-350.0 / -950.0	6.647-704.0	1
3	SCHLAUCH 4X1,5 / HOSE / TUYAU FLEXIBLE ALS METERWARE BESTELLEN/TO ORDER AS CUT GOODS/COMMANDE COMME MARCHANDISE AU METRE	6.389-862.0	1
4	SCHLAUCHTUELLE / HOSE NOZZLE / EMBOUT A OLIVE	6.905-549.0	1
5	SCHLAUCHSCHELLE / HOSE BAND CLIP / COLLIER DE SERRAGE	6.389-993.0	8
6	GEHAUSEUNTERT. KPL / BOTTOM OF COVER / COUVERCLE (PARTIE INF.)	4.060-347.0	1
7	SCHLAUCHSCHELLE / HOSE BAND CLIP / COLLIER DE SERRAGE	6.389-882.0	1
9	SCHRAUBE 5 X 25 / SCREW / VIS	7.303-109.0	2
10	LAUFRAD / FAN WHEEL / ROUE DE VENTILATEUR	5.515-076.0	2
12	LENKROLLE / CASTOR / ROUE PIVOTANTE	6.435-250.0	1
13	LINSENSCHR. 4,2X 13 / OVAL HEAD SCREW / VIS A TETE BOMBEE	6.303-122.0	2
15	ZYL.STIFT 6M6X20 / STRAIGHT PIN / GOUPILLE CYLINDR.	7.314-111.0	1
16	SCHUTZPLATTE / GUARD PLATE / PLAQUE DE GARDE	5.192-032.0	1
17	KABELSATZ REPARATUR / CABLE SET / JEU DE CABLES	6.648-080.0	1
18	SICHERUNGSClip / SECURING CLIP / CLIP	6.343-170.0	1

"=> xxxxxx" = bis Werknummer / up to serial No. / jusqu' au No. de fabr. / "xxxxxx =>" = ab Werknummer / from serial No. / a partir du No. de fabr. /

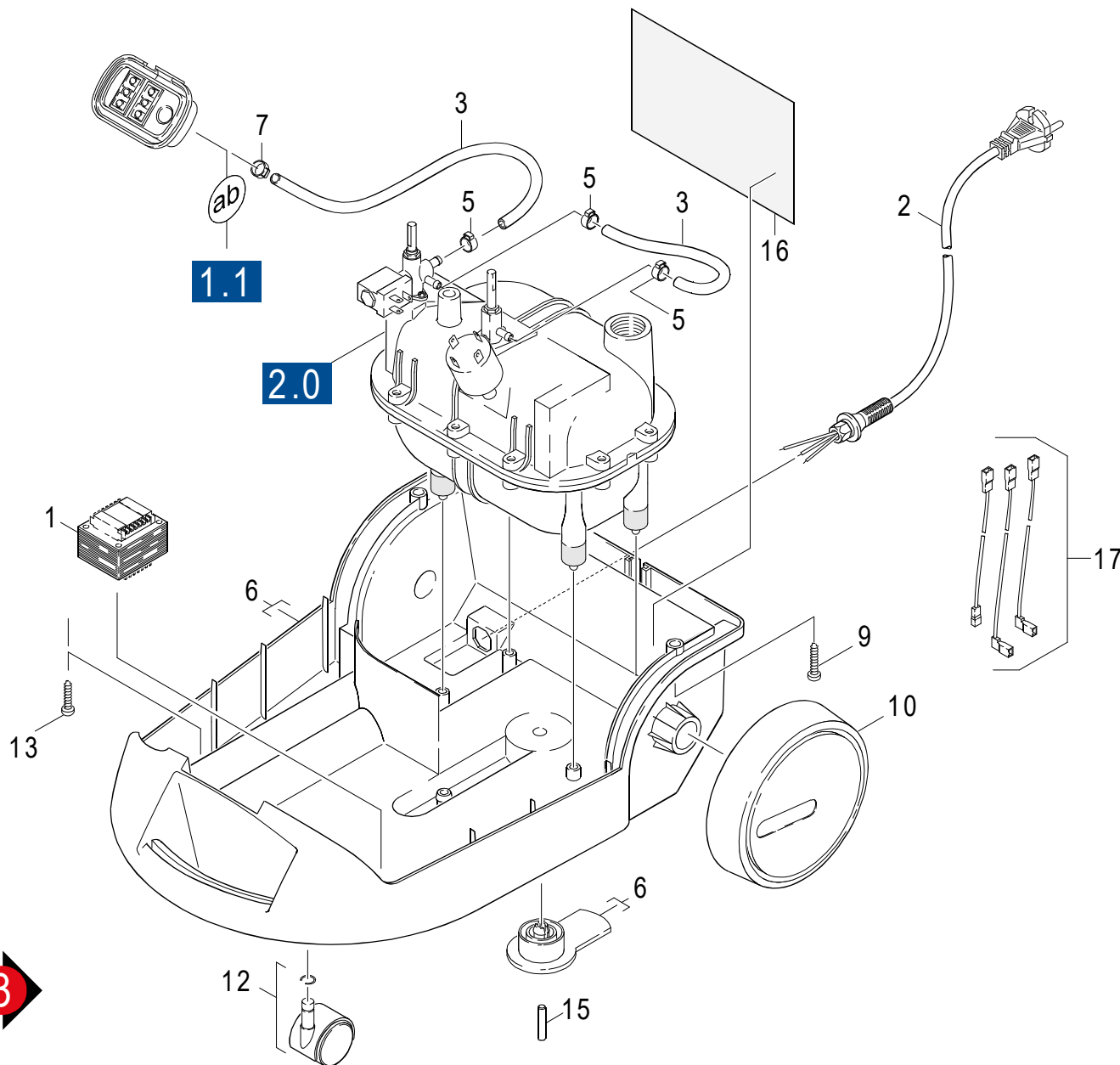

Symbolbeschreibung siehe M16 / symbol description see M16 / désignation de système voir M16 /

GRUPPE: 1.3 GERAET-UNTERTEIL / VERS.3 /
 GROUP: 1.3 APPLIANCE BOTTOM / VERS.3 /
 GROUPE: 1.3 USTENSILE PARTIE INFER. / VERS.3 /

G1

VAP K 1701

POS. ITM. POS.	BENNENUNG DESCRIPTION DESIGNATION	TEILE-NR. PART-NO. NO.PIECE	STCK QTY. NBR.
1	TRANSFORMATOR 10VA / TRANSFORMER / TRANSFORMATEUR	6.622-184.0	1
2	KABEL M.STECKER *EU / CABLE / CABLE / 1.995-120.0 / -400.0 / -402.0 / -900.0	6.647-498.0	1
2	KABEL M. STECKER *CH / CABLE / CABLE / 1.995-290.0 / -401.0 / -403.0 / -930.0	6.647-653.0	1
2	KABEL MIT STECKER / CABLE / CABLE / 1.995-350.0 / -950.0	6.647-704.0	1
3	SCHLAUCH 4X1,5 / HOSE / TUYAU FLEXIBLE ALS METERWARE BESTELLEN/TO ORDER AS CUT GOODS/COMMANDE COMME MARCHANDISE AU METRE	6.389-862.0	1
5	SCHLAUCHSCHELLE / HOSE BAND CLIP / COLLIER DE SERRAGE	6.389-993.0	3
6	GEHAUSEUNTERT. KPL / BOTTOM OF COVER / COUVERCLE (PARTIE INF.)	4.060-347.0	1
7	SCHLAUCHSCHELLE / HOSE BAND CLIP / COLLIER DE SERRAGE	6.389-882.0	1
9	SCHRAUBE 5 X 25 / SCREW / VIS	7.303-109.0	2
10	LAUFRAD / FAN WHEEL / ROUE DE VENTILATEUR	5.515-076.0	2
12	LENKROLLE / CASTOR / ROUE PIVOTANTE	6.435-250.0	1
13	LINSENSCHR. 4,2X 13 / OVAL HEAD SCREW / VIS A TETE BOMBEE	6.303-122.0	2
15	ZYL.STIFT 6M6X20 / STRAIGHT PIN / GOUPILLE CYLINDR.	7.314-111.0	1
16	SCHUTZPLATTE / GUARD PLATE / PLAQUE DE GARDE	5.192-032.0	1
17	KABELSATZ REPARATUR / CABLE SET / JEU DE CABLES	6.648-080.0	1

"=> xxxxxx" = bis Werknummer / up to serial No. / jusqu' au No. de fabr. / "xxxxxx =>" = ab Werknummer / from serial No. / a partir du No. de fabr. /

GRUPPE: 2.0 DAMPFBEHAELTER
GROUP: 2.0 STEAM DRUM
GRUPPE: 2.0 VAPORIGENE

A2

VAP K 1701

GRUPPE: 2.0 DAMPFBEHAELTER
GROUP: 2.0 STEAM DRUM
GRUPPE: 2.0 VAPORIGENE

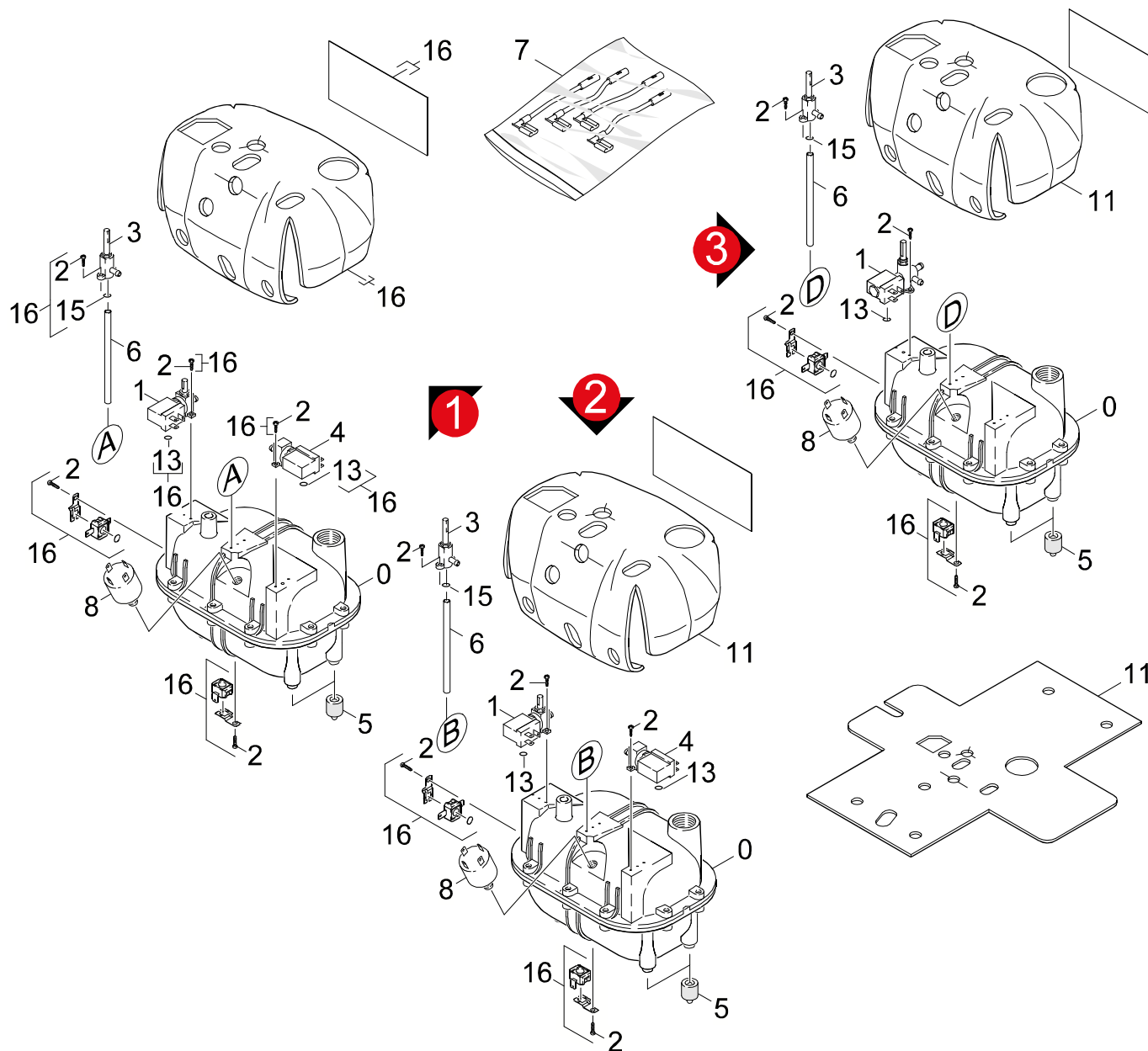

Symbolbeschreibung siehe M16 / symbol description see M16 / désignation de système voir M16 /

GRUPPE: 2.0 DAMPFBEHAELTER
 GROUP: 2.0 STEAM DRUM
 GROUPE: 2.0 VAPORIGENE

C2

VAP K 1701

POS. ITM. POS.	BENNENUNG DESCRIPTION DESIGNATION	TEILE-NR. PART-NO. NO.PIECE	STCK QTY. NBR.
0	KESSEL KPL / BOILER / CUVE VERS. 3	4.070-323.0	1
0	KESSEL KPL ALTE A. / BOILER / CUVE VERS. 1+2	4.070-371.0	1
1	MAGNETVENTIL / SOLENOID VALVE / ELECTROVANNE VERS. 1+2	6.685-267.0	1
1	MAGNETVENTIL / SOLENOID VALVE / ELECTROVANNE VERS. 3	6.686-129.0	1
2	SCHRAUBE M 4X 12 / SCREW / VIS	7.303-032.0	6
3	REGELVENTIL (MECH.) / VALVE / VANNE DE REGULATION	6.686-006.0	1
4	MAGNETVENTIL / SOLENOID VALVE / ELECTROVANNE VERS. 1+2	6.686-008.0	1
5	GUMMIPUFFER / RUBBER BUFFER / BUTOIR CAOUTCHOUC	5.767-006.0	4
6	ROHR HEISSWASSER / PIPE / TUYAU	5.028-765.0	1
7	KABELSATZ REPARATUR / CABLE SET / JEU DE CABLES	6.648-438.0	1
8	DRUCKREGLER / PRESSURE REGULATOR / MANOCONTACT	6.412-280.0	1
11	ISOLIERUNG / INSULATION / ISOLATION	5.673-119.0	1
13	DICHTUNGSSATZ / SET OF GASKETS / ASSORTIMENT DE JOINTS VERS. 1+2	2.881-023.0	1
13	O-RING 8,73X 1,78 / GASKET / BAQUE D'ETANCHEITE VERS. 3	6.362-922.0	1
15	O-RING 7,65X 1,78 / GASKET / BAQUE D'ETANCHEITE	6.362-186.0	1
16	ET-SET THERMOSTATE / SPARE PARTS SET / JEU DE PIECES DECHANGE VERS. 2ISOL.: SCHAUMST. WEISS + DUNKELGRAUER BESCHICHTUNG/INSUL.: WHITE FOAMED MAT. + DARK GREY COATING/ISOL.: MOUSSE BLANCHE + ENDUIT GRIS	4.744-110.0	1
16	UMBAUSATZ THERMOST. / KIT / KIT DE MODIFIC. VERS. 1ISOL.: GLASWOLLE OCKERFARBEN/INSUL.: GLASS WOOL OCHRE/ISOL.: LAINE DE VERRE OCRE	4.744-122.0	1

"=> xxxxxx" = bis Werknummer / up to serial No. / jusqu' au No. de fabr. / "xxxxxx =>" = ab Werknummer / from serial No. / a partir du No. de fabr. /

GRUPPE: 3.0 SCHLAUCH
GROUP: 3.0 HOSE
GRUPPE: 3.0 TUYAU FLEXIBLE

A3

VAP K 1701

GRUPPE: 3.0 SCHLAUCH
GROUP: 3.0 HOSE
GRUPPE: 3.0 TUYAU FLEXIBLE

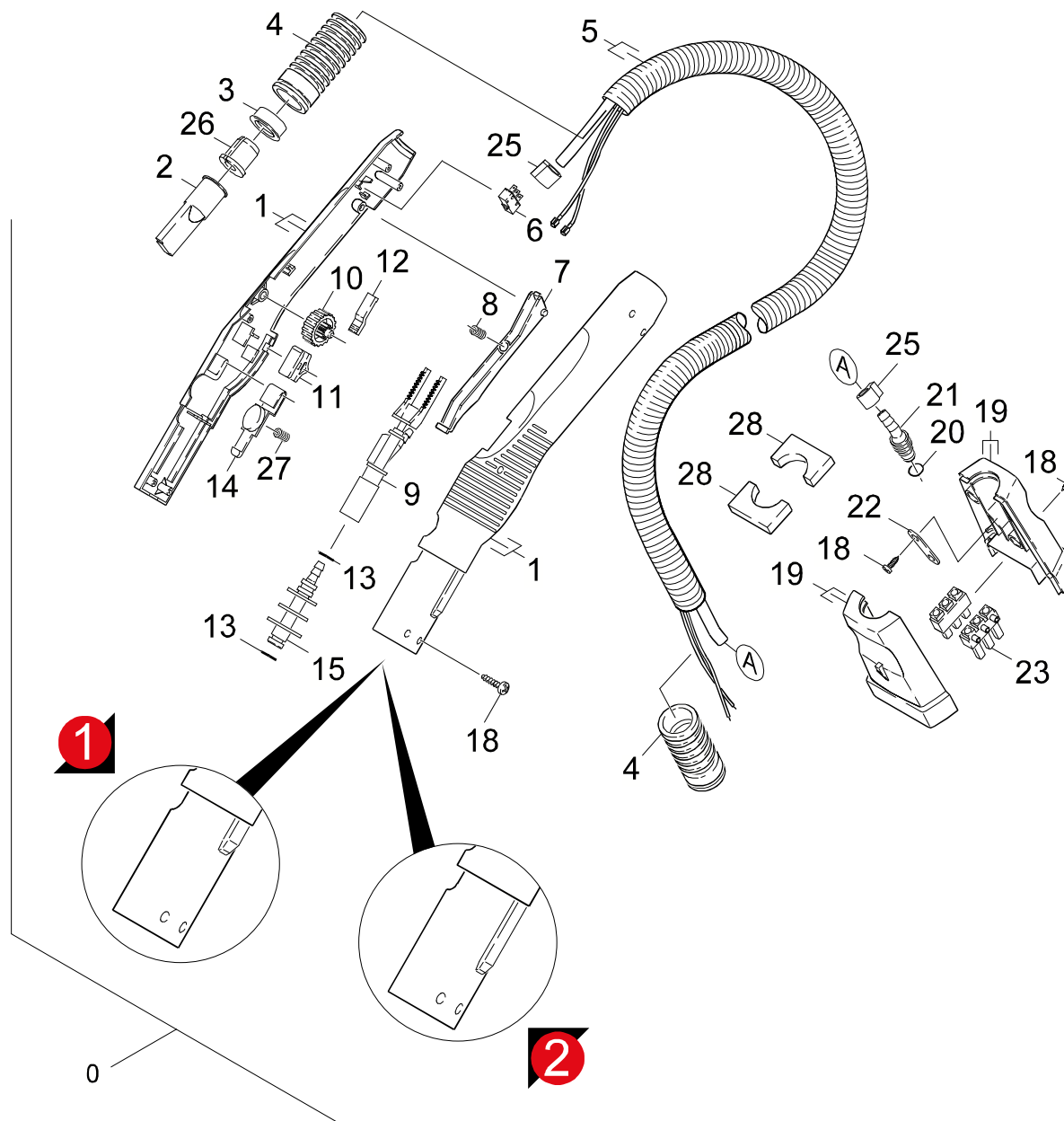

Symbolbeschreibung siehe M16 / symbol description see M16 / désignation de système voir M16 /

GRUPPE: 3.0 SCHLAUCH
 GROUP: 3.0 HOSE
 GROUPE: 3.0 TUYAU FLEXIBLE

C3

VAP K 1701

POS. ITM. POS.	BENNENUNG DESCRIPTION DESIGNATION	TEILE-NR. PART-NO. NO.PIECE	STCK QTY. NBR.
0	TAUSCHSET ZUB.K1701 / EXCHANGE SET / TAUSCHSET ZUB.K1701 VERS. 1	2.638-745.0	1
0	DAMPFSCHLAUCH KPL. / STEAM HOSE / TUYAU FLEXIBLE (VAPEUR) VERS. 2	4.321-088.0	1
1	GRIFFPaar / HANDLES / BRANCHES POIGNEE VERS. 1	5.321-468.0	1
1	GRIFFPaar / HANDLES / BRANCHES POIGNEE VERS. 2	5.321-510.0	1
2	MEMBRANE / DIAPHRAGM / MEMBRANE	5.367-024.0	1
3	MEMBRANRING / DIAPHRAGM RING / BAGUE	5.367-025.0	1
4	SCHUTZTEIL / PROTECTION PART / PARTIE PROTECTEUR	5.394-374.0	2
5	SCHLAUCH KPL. / HOSE / TUYAU FLEXIBLE	4.440-480.0	1
6	MICROSCHALTER / MICRORUPTEUR / MICROINTERRUPTOR	6.631-802.0	1
7	TASTER / CALIPER / BOUTON POUSSOIR	5.324-029.0	1
8	DRUCKFEDER / PRESSURE SPRING / RESSORT A PRESSION	5.332-168.0	1
9	VENTIL KPL. / VALVE / SOUPEPE	4.580-301.0	1
10	HANDRAD / HAND WHEEL / VOLANT	5.322-010.0	1
11	SCHIEBER / BOLT / VERROU	5.031-064.0	1
12	RASTER / SCREEN / RESEAU	5.031-125.0	1
13	O-RING 8,73X 1,78 / GASKET / BAQUE D'ETANCHEITE	6.362-922.0	2
14	HAKEN / HOOK / PATERE	5.037-102.0	1
15	KUPPLUNGSTEIL / COUPLING ELEMENT / PIECE D'ACCOUPL.	5.471-078.0	1
18	LINSENSCHR. 2,9X 13 / OVAL HEAD SCREW / VIS A TETE BOMBEE	6.303-058.0	10
19	STECKER (SCHALEN) / PLUG / FICHE	5.031-060.0	1
20	O-RING 6,75X 1,78 / GASKET / BAQUE D'ETANCHEITE	6.362-923.0	1
21	NIPPEL / NIPPLE / NIPPLE	5.409-218.0	1
22	ZUGENTLASTUNG / PULL RELIEF / DECHARGE DETRACTION	6.647-513.0	1
23	STECKERTEIL / PLUG ELEMENT / PIECE CONNECTEUR	6.646-325.0	2
25	SCHLAUCHSCHE. 11,8 / HOSE BAND CLIP / COLLIER DE SERRAGE	6.389-884.0	2
26	ZUGENTLASTUNG / PULL RELIEF / DECHARGE DETRACTION	5.031-123.0	1
27	SCHRAUBENFEDER / HELICAL SPRING / RESSORT CYLINDRIQUE	5.332-373.0	1
28	FLACHDICHTUNG / GASKET / GARNITURE PLATE	5.364-174.0	2

"=> xxxxxx" = bis Werknummer / up to serial No. / jusqu' au No. de fabr. / "xxxxxx =>" = ab Werknummer / from serial No. / a partir du No. de fabr. /

GRUPPE: 4.0 VERLAENGERUNG
GROUP: 4.0 EXTENSION
GRUPPE: 4.0 RALLONGE

A4

VAP K 1701

GRUPPE: 4.0 VERLAENGERUNG
GROUP: 4.0 EXTENSION
GRUPPE: 4.0 RALLONGE

Ersatzteile unter www.gluesing.net

GRUPPE: 4.0 VERLAENGERUNG
GROUP: 4.0 EXTENSION
GRUPPE: 4.0 RALLONGE

B4

VAP K 1701

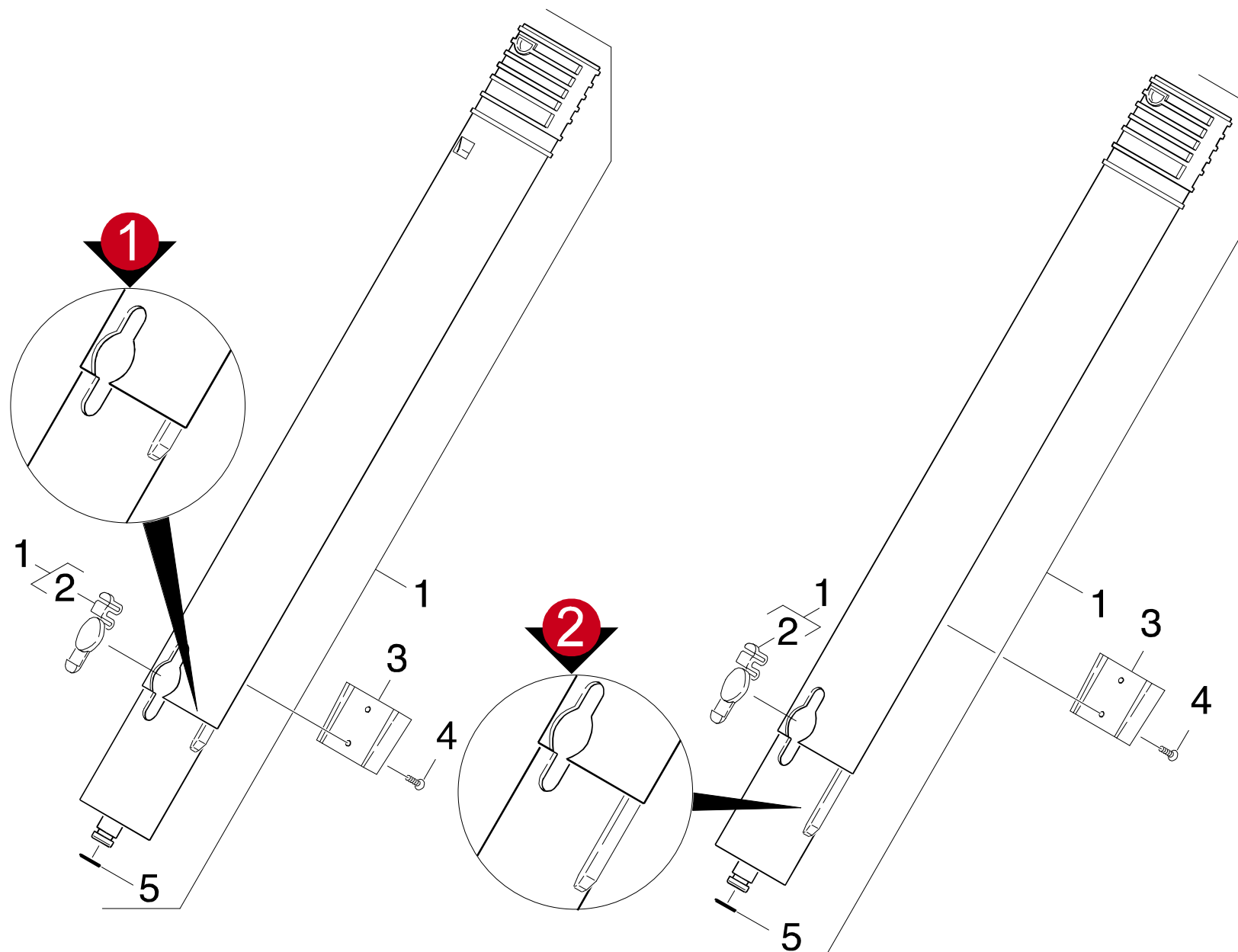

Symbolbeschreibung siehe M16 / symbol description see M16 / désignation de système voir M16 /

GRUPPE: 4.0 VERLAENGERUNG
GROUP: 4.0 EXTENSION
GROUPE: 4.0 RALLONGE

C4

VAP K 1701

POS. ITM. POS.	BENNENUNG DESCRIPTION DESIGNATION	TEILE-NR. PART-NO. NO.PIECE	STCK QTY. NBR.
1	VERLAENGERUNGSROHR / EXTENSION PIPE / TUBULURE VERS. 1	4.127-010.0	2
1	VERLAENGERUNGSROHR / EXTENSION PIPE / TUBULURE VERS. 2	4.127-012.0	2
2	RASTHAKEN / HOOK / PATERE	5.037-103.0	2
3	HALTER / BRACKET / FIXATION	5.042-873.0	1
4	SENKCHR. 2,9X9,5 / FLAT HEADED SCREW / VIS A TETE CONIQUE	6.303-051.0	2
5	O-RING 8,73X 1,78 / GASKET / BAQUE D'ETANCHEITE	6.362-922.0	2

"=> xxxxxx" = bis Werknummer / up to serial No. / jusqu' au No. de fabr. / "xxxxxx =>" = ab Werknummer / from serial No. / a partir du No. de fabr. /

GRUPPE: 5.0 BUERSTEN
GROUP: 5.0 BRUSHES
GRUPPE: 5.0 BROSSES

A5

VAP K 1701

GRUPPE: 5.0 BUERSTEN
GROUP: 5.0 BRUSHES
GRUPPE: 5.0 BROSSES

GRUPPE: 5.0 BUERSTEN
GROUP: 5.0 BRUSHES
GRUPPE: 5.0 BROSSES

B5

VAP K 1701

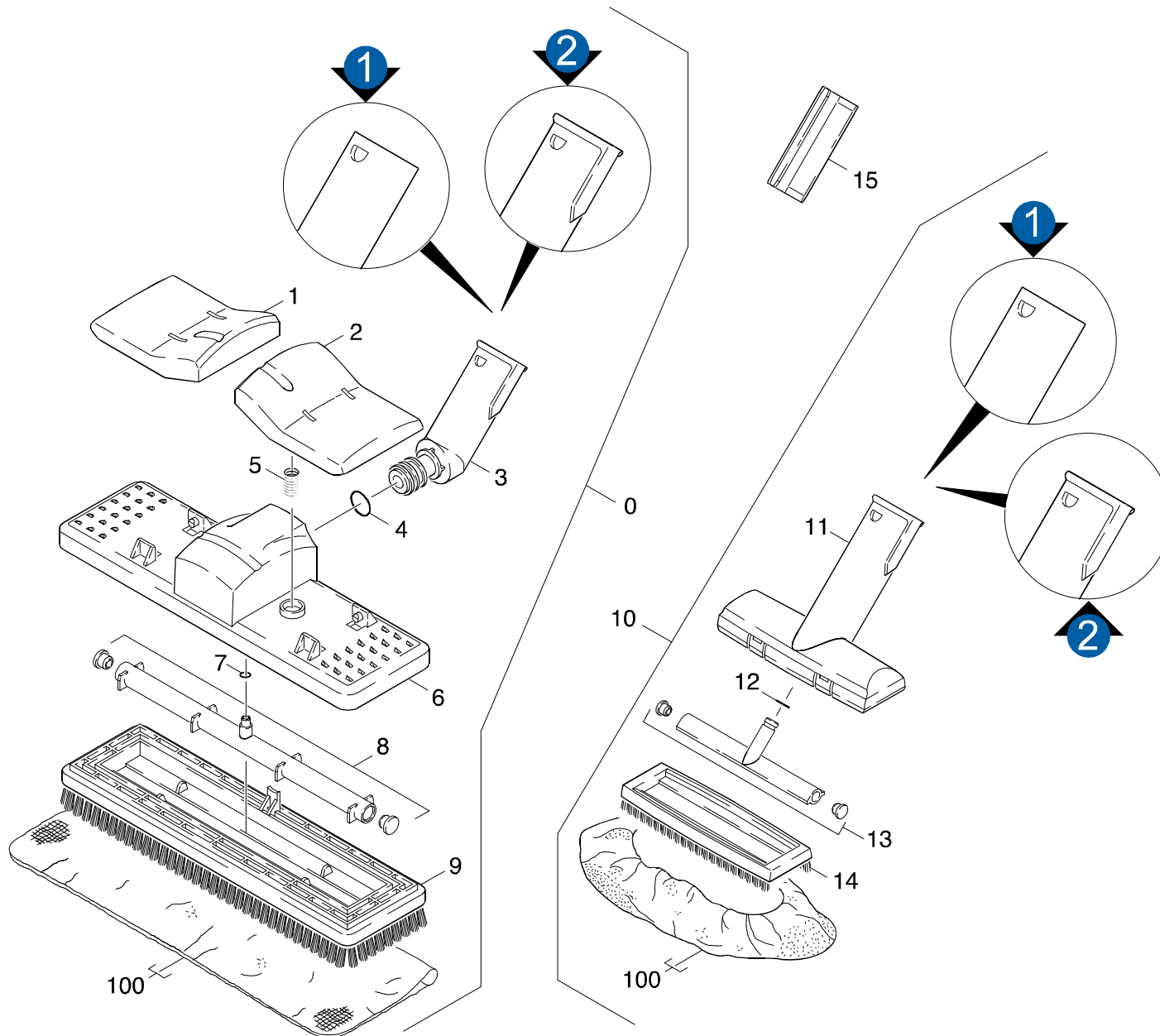

Symbolbeschreibung siehe M16 / symbol description see M16 / désignation de système voir M16 /

GRUPPE: 5.0 BUERSTEN
 GROUP: 5.0 BRUSHES
 GROUPE: 5.0 BROSSES

C5

VAP K 1701

POS. ITM. POS.	BENNENUNG DESCRIPTION DESIGNATION	TEILE-NR. PART-NO. NO.PIECE	STCK QTY. NBR.
0	BODENDUESE KPL. / FLOOR TOOL / SUCEUR VERS. 1	4.130-103.0	1
0	BODENDUESE KPL. / FLOOR TOOL / SUCEUR VERS. 2	4.130-113.0	1
1	HALTER / BRACKET / FIXATION VERS. 2	5.042-940.0	1
2	HALTER / BRACKET / FIXATION VERS. 2	5.042-939.0	1
3	ROHRKRUEMMER / ELBOW / COUDE DE TUBE VERS. 1	5.408-052.0	1
3	ROHRKRUEMMER / ELBOW / COUDE DE TUBE VERS. 2	5.408-053.0	1
4	O-RING 18,0 X 2,5 / GASKET / BAQUE D'ETANCHEITE	6.362-883.0	2
5	FEDER / SPRING / RESSORT	6.330-016.0	2
6	DUESENGEHAEUSE / NOZZLE CASE / CORPS DE BUSE VERS. 1	5.768-037.0	1
6	DUESENGEHAEUSE / NOZZLE CASE / CORPS DE BUSE VERS. 2	5.768-047.0	1
7	O-RING 6,07X 1,78 / GASKET / BAQUE D'ETANCHEITE	6.362-881.0	1
8	DUESENKOERPER / NOZZLE BODY / CORPS DE BUSE	5.768-038.0	1
9	BUERSTENEINSATZ / BRUSH INSERT / ELEMENT DE BROSSE	5.762-135.0	1
10	HANDDUESE / HAND NOZZLE / BUSE A MAIN VERS. 1	4.130-101.0	1
10	HANDDUESE / HAND NOZZLE / BUSE A MAIN VERS. 2	4.130-111.0	1
11	DUESENGEHAEUSE / NOZZLE CASE / CORPS DE BUSE VERS. 1	5.768-033.0	1
11	DUESENGEHAEUSE / NOZZLE CASE / CORPS DE BUSE VERS. 2	5.768-043.0	1
12	O-RING 8,73X 1,78 / GASKET / BAQUE D'ETANCHEITE	6.362-922.0	1
13	DUESENKOERPER / NOZZLE BODY / CORPS DE BUSE	5.768-034.0	1
14	BUERSTENEINSATZ / BRUSH INSERT / ELEMENT DE BROSSE	5.762-134.0	1
15	FORMTEIL / MOULDED PART / PREFORME	5.031-467.0	1
100	TUCHSET / CLOTHS FOR CLEANING MACH. / LOT DE CHIFFONS	6.960-019.0	1

"=> xxxxxx" = bis Werknummer / up to serial No. / jusqu' au No. de fabr. / "xxxxxx =>" = ab Werknummer / from serial No. / a partir du No. de fabr. /

GRUPPE: 6.0 DUESE
GROUP: 6.0 NOZZLE
GRUPPE: 6.0 BUSE

A6

VAP K 1701

**GRUPPE: 6.0 DUESE
GROUP: 6.0 NOZZLE
GRUPPE: 6.0 BUSE**

GRUPPE: 6.0 DUESE
GROUP: 6.0 NOZZLE
GRUPPE: 6.0 BUSE

B6

VAP K 1701

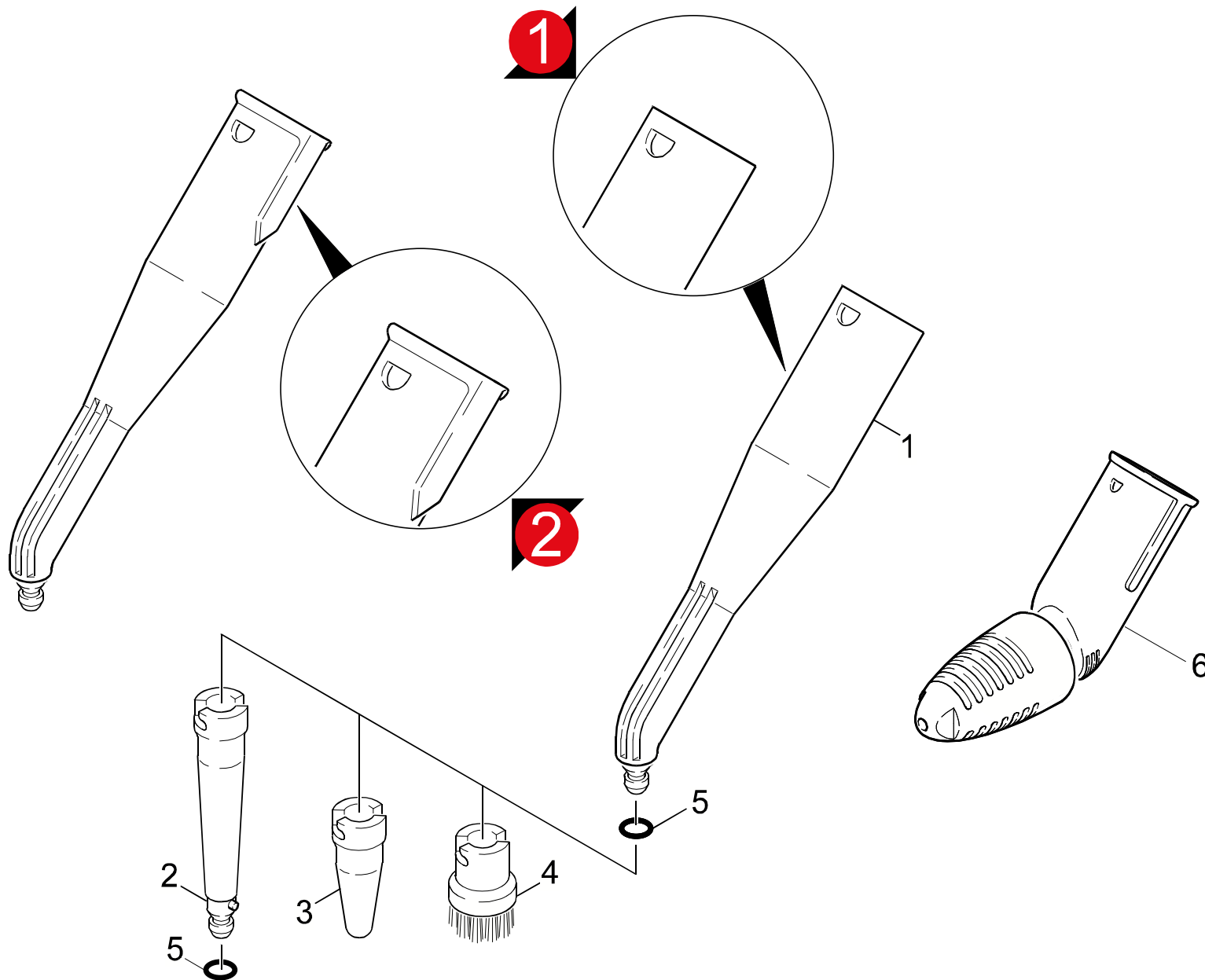

Symbolbeschreibung siehe M16 / symbol description see M16 / désignation de système voir M16 /

GRUPPE: 6.0 DUESE
GROUP: 6.0 NOZZLE
GROUPE: 6.0 BUSE

C6

VAP K 1701

POS.	BENNENNUNG	TEILE-NR.	STCK
ITM.	DESCRIPTION	PART-NO.	QTY.
POS.	DESIGNATION	NO.PIECE	NBR.

1	PUNKTSTRAHL DUESE / NOZZLE / GICLEUR	4.130-174.0	1
1	PUNKTSTRAHL DUESE / NOZZLE / GICLEUR	5.130-167.0	1
	VERSION 1		
2	VERLAENGERUNG / EXTENSION / RALLONGE	5.762-138.0	1
3	POWERDUESE / POWER NOZZLE / BUSE	5.762-139.0	1
4	BORSTENKRANZ-SET / BRISTLE RINK SET / KIT COURONNE POILS DURS	2.863-058.0	1
	STANDARD/STANDARD/STANDARD		
4	BORSTENKRANZ-SET MS / BRISTLE RINK SET / KIT COURONNE POILS DURS	2.863-061.0	1
	ALTERNATIVE/ALTERNATIVE/ALTERNATIVE		
5	O-RING 6,02X 2,62 / GASKET / BAQUE D'ETANCHEITE	6.362-924.0	2
6	ROTORDUESE DAMPFER / ROTARY NOZZLE / BUSE JET ROTATIF	2.863-094.0	1
	/ 1.995-120.0 / -900.0 / -901.0		

"=> xxxxxx" = bis Werknummer / up to serial No. / jusqu' au No. de fabr. / "xxxxxx =>" = ab Werknummer / from serial No. / a partir du No. de fabr. /

GRUPPE: 7.0 FENSTERDUESE
GROUP: 7.0 WINDOW TOOL
GRUPPE: 7.0 SUCEUR POUR FENETRE

A7

VAP K 1701

GRUPPE: 7.0 FENSTERDUESE
GROUP: 7.0 WINDOW TOOL
GRUPPE: 7.0 SUCEUR POUR FENETRE

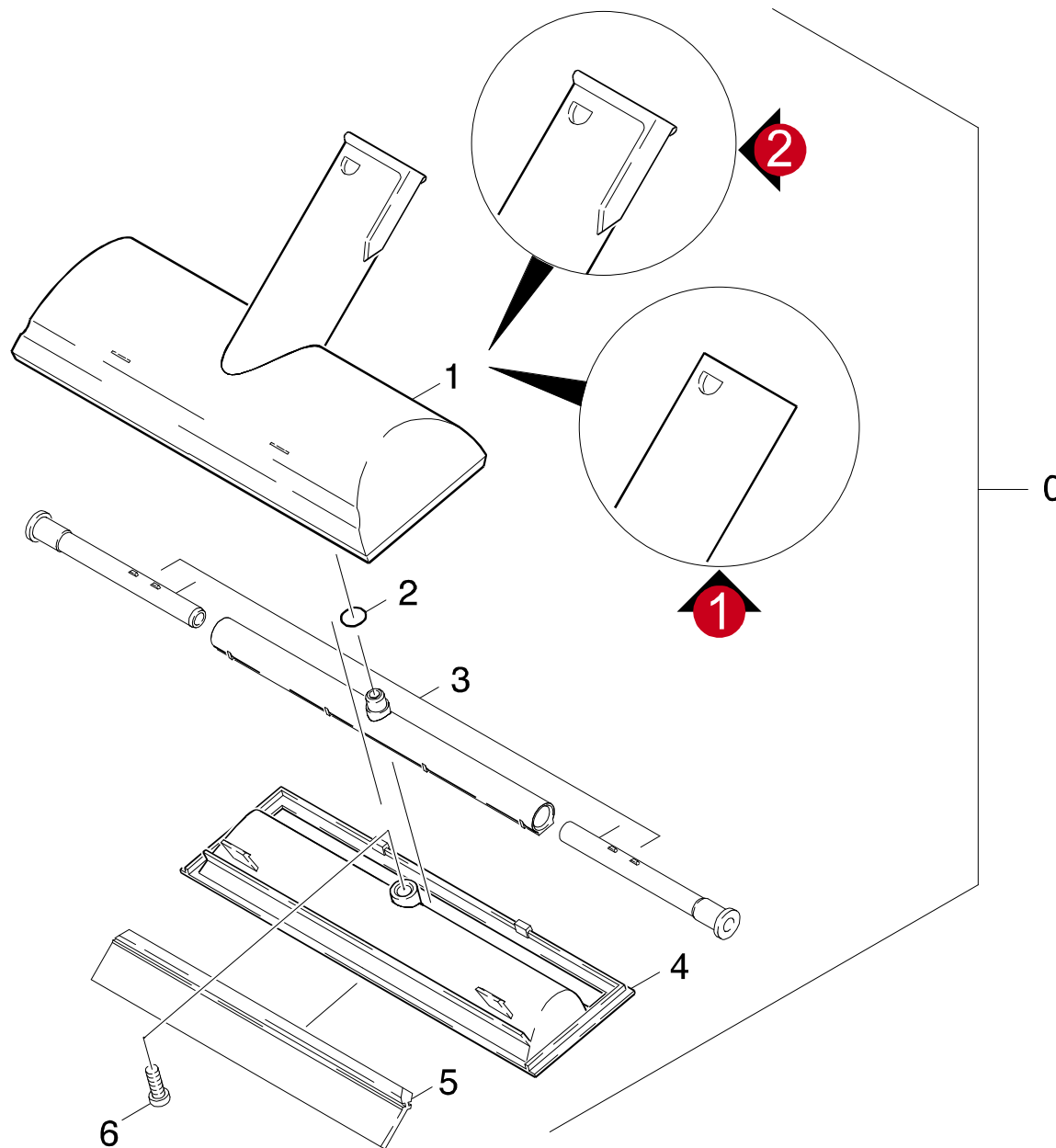

Symbolbeschreibung siehe M16 / symbol description see M16 / désignation de système voir M16 /

GRUPPE: 7.0 FENSTERDUESE
GROUP: 7.0 WINDOW TOOL
GROUPE: 7.0 SUCEUR POUR FENETRE

C7

VAP K 1701

POS. ITM. POS.	BENNENUNG DESCRIPTION DESIGNATION	TEILE-NR. PART-NO. NO.PIECE	STCK QTY. NBR.
0	FENSTERDUESE KPL. / WINDOW TOOL / SUCEUR POUR FENETRE VERSION 1	4.130-102.0	1
0	FENSTERDUESE / WINDOW TOOL / SUCEUR POUR FENETRE VERSION 2	4.130-115.0	1
1	DUESENOBERTEIL / TOP PART / PARTIE SUPERIEUR VERSION 1	5.768-035.0	1
1	DUESENOBERTEIL / TOP PART / PARTIE SUPERIEUR VERSION 2	5.768-044.0	1
2	O-RING 8,73X 1,78 / GASKET / BAQUE D'ETANCHEITE	6.362-922.0	1
3	DUESENKOERPER / NOZZLE BODY / CORPS DE BUSE	4.768-016.0	1
4	DUESENUNTERTEIL / BOTTOM / PARTIE INFERIEURE	5.768-036.0	1
5	GUMMILIPPE / RUBBER LIP / LEVRE CAOUTCHOUC	6.273-140.0	1
6	LINSENSCHR. 2,9X 13 / OVAL HEAD SCREW / VIS A TETE BOMBEE	6.303-058.0	1

"=> xxxxxx" = bis Werknummer / up to serial No. / jusqu' au No. de fabr. / "xxxxxx =>" = ab Werknummer / from serial No. / a partir du No. de fabr. /

GRUPPE: 8.0 WASSERFILTER
GROUP: 8.0 WATER FILTER
GRUPPE: 8.0 FILTRE (EAU)

A8

VAP K 1701

GRUPPE: 8.0 WASSERFILTER
GROUP: 8.0 WATER FILTER
GRUPPE: 8.0 FILTRE (EAU)

GRUPPE: 8.0 WASSERFILTER
GROUP: 8.0 WATER FILTER
GRUPPE: 8.0 FILTRE (EAU)

B8

VAP K 1701

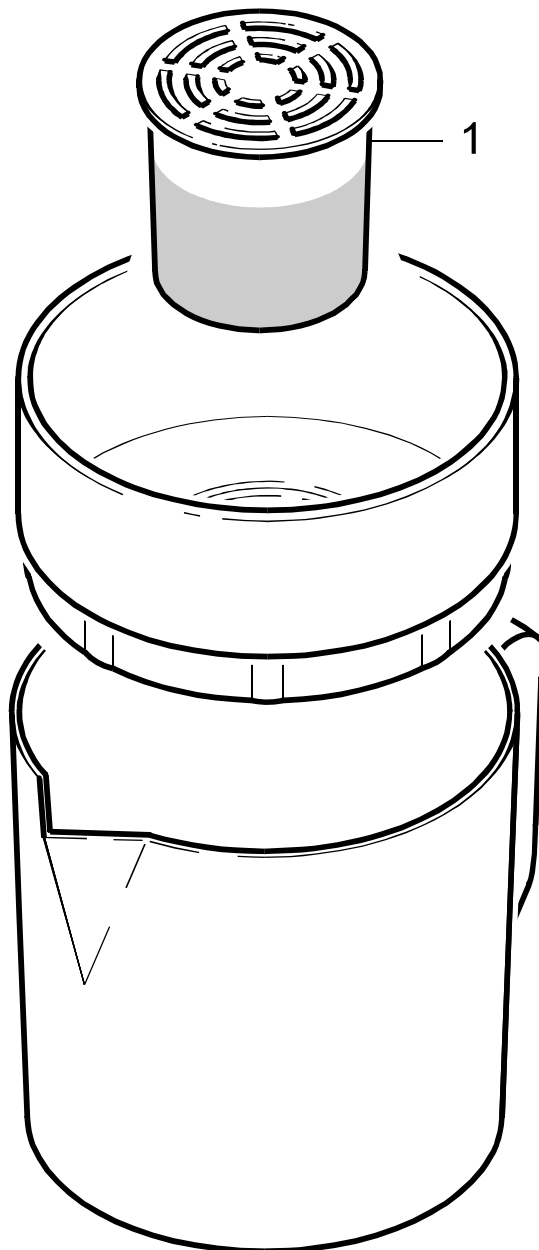

Symbolbeschreibung siehe M16 / symbol description see M16 / désignation de système voir M16 /

GRUPPE: 8.0 WASSERFILTER
GROUP: 8.0 WATER FILTER
GRUPPE: 8.0 FILTRE (EAU)

C8

VAP K 1701

POS.	BENNENUNG	TEILE-NR.	STCK
ITM.	DESCRIPTION	PART-NO.	QTY.
POS.	DESIGNATION	NO.PIECE	NBR.

1	PATRONE -NACHFUELL / CARTRIDGE / CHARGEUR	6.370-957.0	1
---	---	-------------	---

"=> xxxxxx" = bis Werknummer / up to serial No. / jusqu' au No. de fabr. / "xxxxxx =>" = ab Werknummer / from serial No. / a partir du No. de fabr. /

GRUPPE: 9.0 BUEGELEISEN
GROUP: 9.0 SMOOTHING IRON
GRUPPE: 9.0 FER A REPASSER

A9

VAP K 1701

GRUPPE: 9.0 BUEGELEISEN
GROUP: 9.0 SMOOTHING IRON
GRUPPE: 9.0 FER A REPASSER

Ersatzteile unter www.gluesing.net

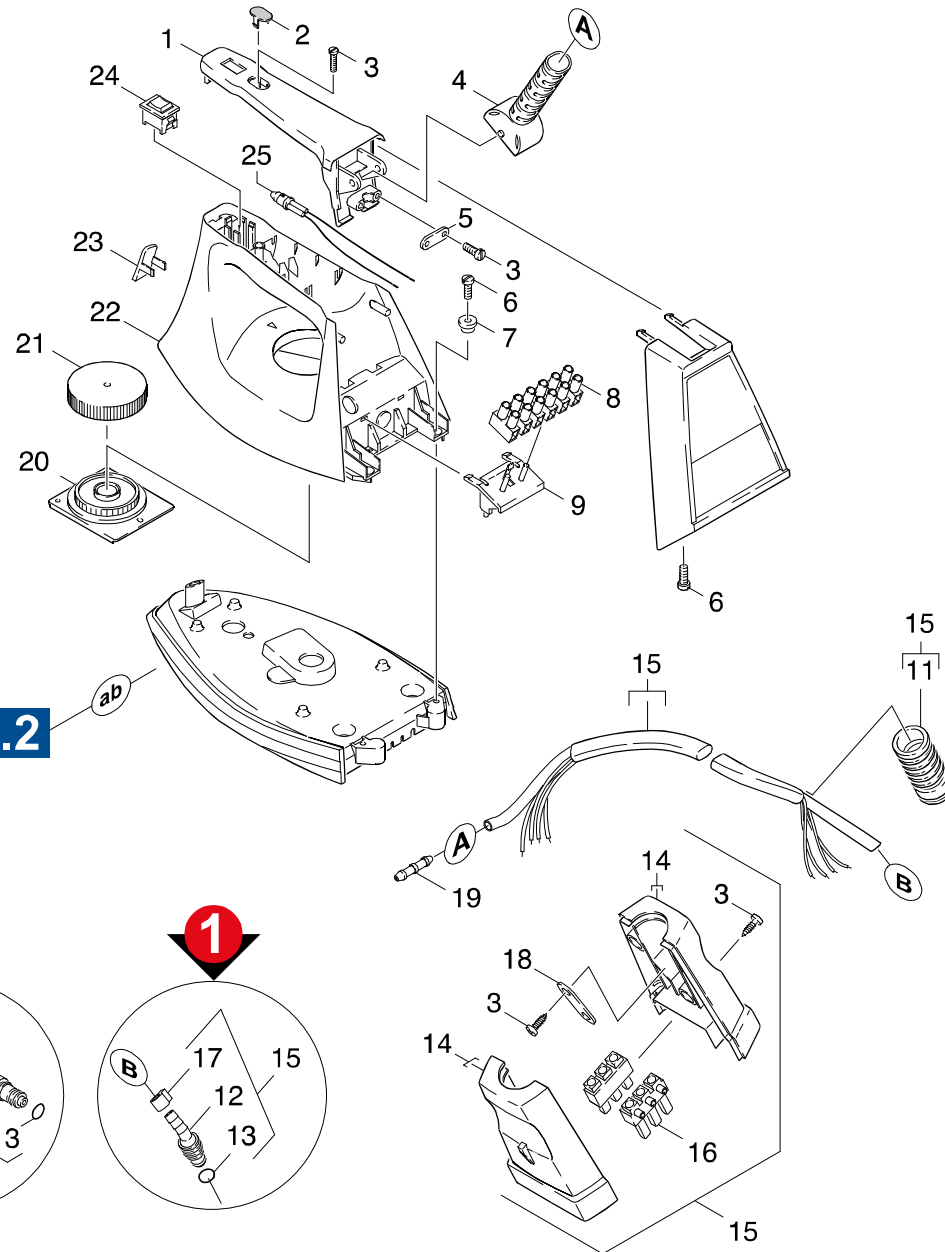

Symbolbeschreibung siehe M16 / symbol description see M16 / désignation de système voir M16 /

GRUPPE: 9.1 BUEGELEISEN / VERSION 1 /
 GROUP: 9.1 SMOOTHING IRON / VERSION 1 /
 GROUPE: 9.1 FER A REPASSER / VERSION 1 /

C9

VAP K 1701

POS. ITM. POS.	BENNENUNG DESCRIPTION DESIGNATION	TEILE-NR. PART-NO. NO.PIECE	STCK QTY. NBR.
0	BUEGELEISEN / SMOOTHING IRON / FER A REPASSER	6.960-018.0	1
1	GRIFFABDECKUNG LGR / COVER / COUVERCLE	6.960-104.0	1
2	LAMPENABDECKUNG / COVER / COUVERCLE	6.960-105.0	1
3	LINSENSCHR. 2,9X 13 / OVAL HEAD SCREW / VIS A TETE BOMBEE	6.303-058.0	8
4	KNICKSCHUTZTUELLE / BEND PROTECTION SPOUT / PASSE-CABLE	6.960-106.0	1
5	ZUGENTLASTUNG / PULL RELIEF / DECHARGE DETRACTION	6.960-107.0	1
6	BL.SCHR. ST3,5X16,0 / SHEET METAL SCREW / VIS A TOLE	7.303-363.0	4
7	GUMMILAGER / RUBBER BEARING / PALIER EN CAOUTCHOUC	6.960-109.0	2
8	KLEMMENLEISTE 6POL. / STRIP TERMINAL / BORNE PLATE	6.960-110.0	1
9	TRAEGER / CARRIER / LONGERON	6.960-111.0	1
11	SCHUTZTEIL / PROTECTION PART / PARTIE PROTECTEUR	5.394-374.0	1
12	NIPPEL / NIPPLE / NIPPLE	5.409-218.0	1
	VERSION 1		
12	KOLBEN / PISTON / PISTON	5.553-339.0	1
	VERSION 2		
13	O-RING 6,75X 1,78 / GASKET / BAQUE D'ETANCHEITE	6.362-923.0	1
14	STECKER (SCHALEN) / PLUG / FICHE	5.031-060.0	1
15	ANSCHLUSSLEITUNG / CONNECTING CABLE / CABLE D'ALIMENTATION	6.960-157.0	1
16	STECKERTEIL / PLUG ELEMENT / PIECE CONNECTEUR	6.646-325.0	2
17	SCHLAUCHSCHELLE / HOSE BAND CLIP / COLLIER DE SERRAGE	6.389-992.0	1
18	ZUGENTLASTUNG / PULL RELIEF / DECHARGE DETRACTION	6.647-513.0	1
19	SCHLAUCHNIPPEL / HOSE STEM / RACCORD DE FLEXIBLE	6.960-130.0	1
20	RASTEREINSATZ / INSERT / INSERT	6.960-122.0	1
21	REGULIERRAD WEISS / CONTROL WHEEL / VOLANT DE REGULATION	6.960-123.0	1
22	GEHAEUSE SIGNALGRAU / HOUSING / BOITIER	6.960-127.0	1
23	ABDECKUNG LICHTGRAU / COVER / CHAPEAU	6.960-124.0	1
24	UMSCHALTER / SWITCH / INVERSEUR	6.960-125.0	1
25	LAMPE / LAMP / LAMPE	6.960-126.0	1

"=> xxxxxx" = bis Werknummer / up to serial No. / jusqu' au No. de fabr. / "xxxxxx =>" = ab Werknummer / from serial No. / a partir du No. de fabr. /

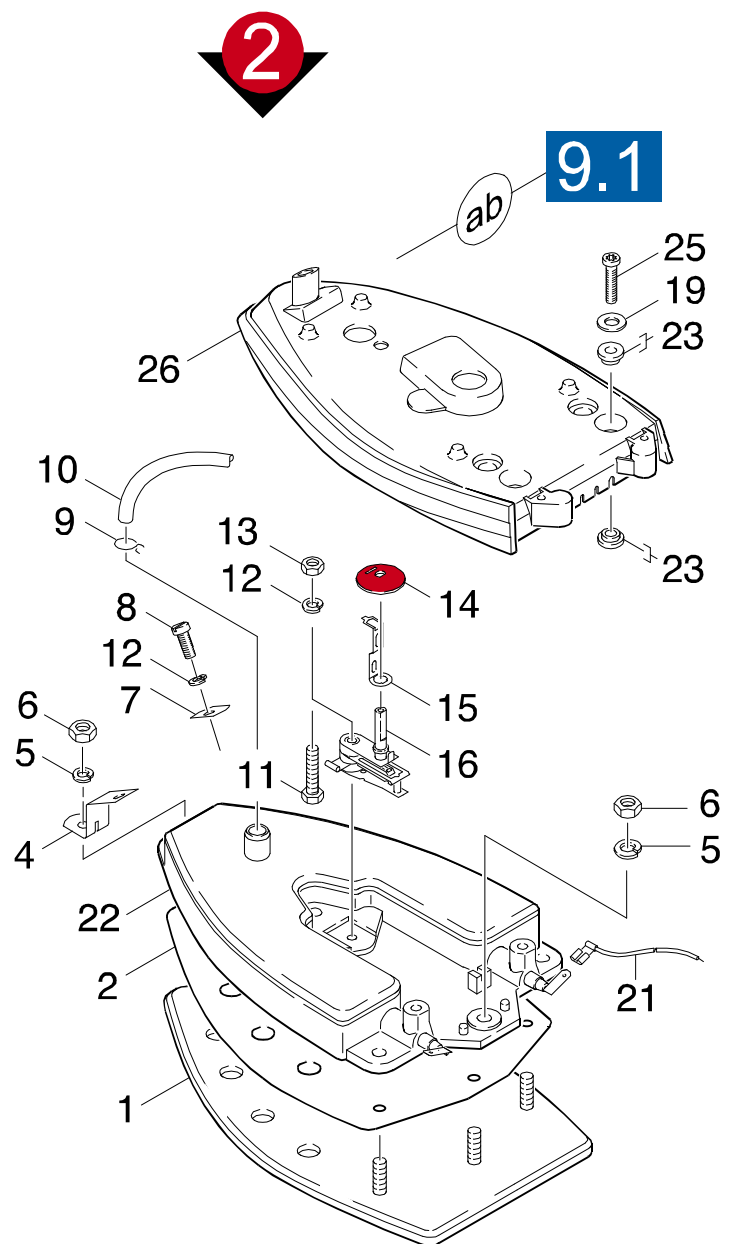
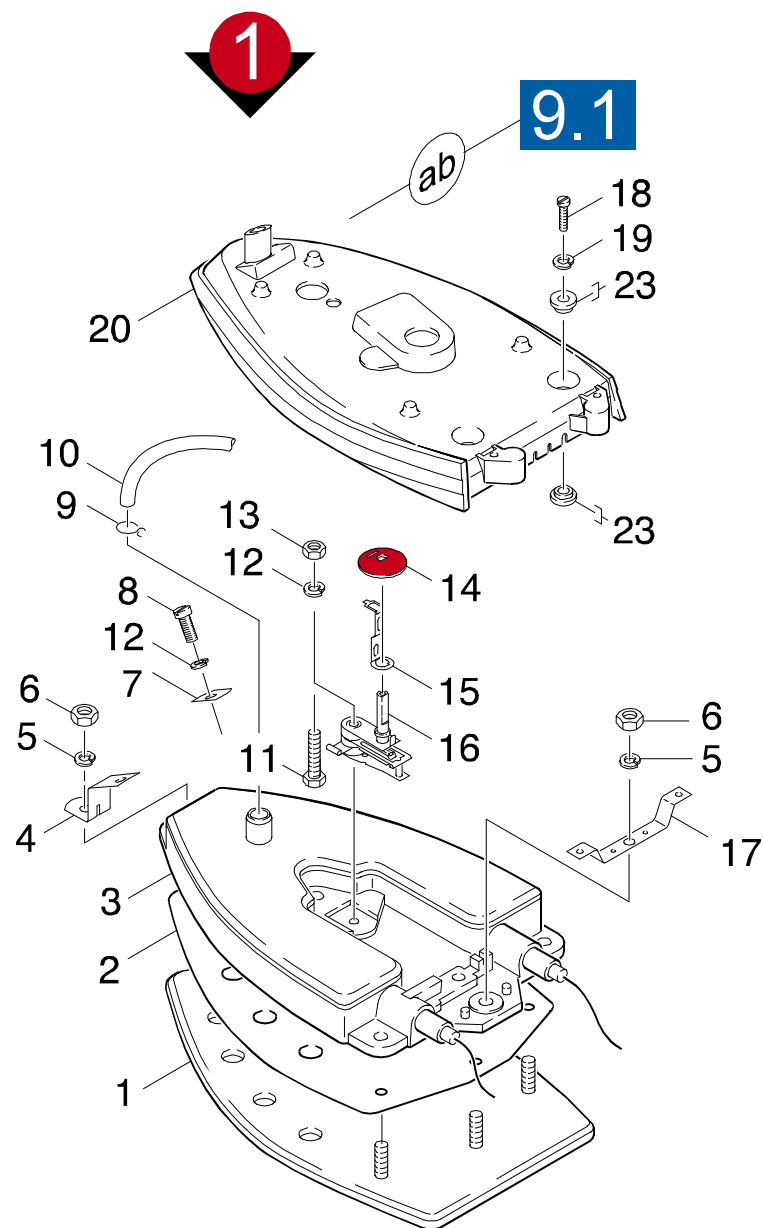

Symbolbeschreibung siehe M16 / symbol description see M16 / désignation de système voir M16 /

GRUPPE: 9.2 BUEGELEISEN / VERSION 2 /
 GROUP: 9.2 SMOOTHING IRON / VERSION 2 /
 GROUPE: 9.2 FER A REPASSER / VERSION 2 /

E9

VAP K 1701

POS. ITM. POS.	BENNENUNG DESCRIPTION DESIGNATION	TEILE-NR. PART-NO. NO.PIECE	STCK QTY. NBR.
1	GRUNDPLATTE / BASE PLATE / PLAQUE DE BASE	6.960-118.0	1
2	GLEITFOLIE / FOIL / FEUILLE	6.960-129.0	1
3	HEIZEINSATZ KPL. / HEATING ELEMENT CPL. / ELEMENT CHAUFFAGE CPL.	6.960-117.0	1
4	BUEGEL / STRAP / ETRIER	6.960-119.0	1
5	FEDERRING A 5 / SPRING WASHER / RONDELLE GROWER	7.313-032.0	2
6	6KT-MUTTER M 5 / HEXAGON NUT / ECROU HEXAGONAL	7.311-065.0	2
7	PLATTE / PLATE / PLAQUE	6.960-128.0	1
8	ZYL.SCHR. M 4X 20 / CHEESE HEAD SCREW / VIS A TETE CYLINDR.	7.306-488.0	1
9	KLEMMFEDER / SPRING / RESSORT DE FRICTION	6.960-120.0	1
10	SCHLAUCHSTUECK / HOSE / BOUT DE TUYAU	6.960-121.0	1
11	6KT-SCHR. M 4X 35 / HEXAGONAL HEAD SCREW / VIS HEXAGONAL	7.304-043.0	1
12	FEDERRING A 4 / SPRING WASHER / RONDELLE GROWER	7.313-031.0	5
13	6KT-MUTTER M 4 / HEXAGON NUT / ECROU HEXAGONAL	7.311-064.0	1
14	ABDECKUNG / COVER / CHAPEAU	6.960-113.0	1
15	MITNEHMER / CARRIER / ENTRAINEUR	6.960-114.0	1
16	KOMBIREGLER / CONTROL DEVICE / REGULATEUR	6.960-115.0	1
17	BUEGEL / STRAP / ETRIER	6.960-116.0	1
	VERSION 1		
18	ZYL.SCHR. M 4X 8 / CHEESE HEAD SCREW / VIS A TETE CYLINDR.	7.306-489.0	2
	VERSION 1		
19	SCHEIBE 4 / WASHER / RONDELLE	7.312-293.0	4
20	HAUBE SIGNALGRAU / COVER / CAPOT	6.960-112.0	1
	VERSION 1		
21	KABEL / CABLE / CABLE	6.960-193.0	2
	VERSION 2		
22	HEIZEINSATZ KPL. / HEATING ELEMENT CPL. / ELEMENT CHAUFFAGE CPL.	6.960-194.0	1
	VERSION 2		
23	ISOLIERSCHEIBE / INSULATING WASHER / RONDELLE ISOLANTE	6.960-195.0	2
25	SCHRAUBE M 4X 16 / SCREW / VIS	7.303-033.0	2
26	HAUBE SIGNALGRAU / COVER / CAPOT	6.960-196.0	1
	VERSION 2		

"=> xxxxxx" = bis Werknummer / up to serial No. / jusqu' au No. de fabr. / "xxxxxx =>" = ab Werknummer / from serial No. / a partir du No. de fabr. /

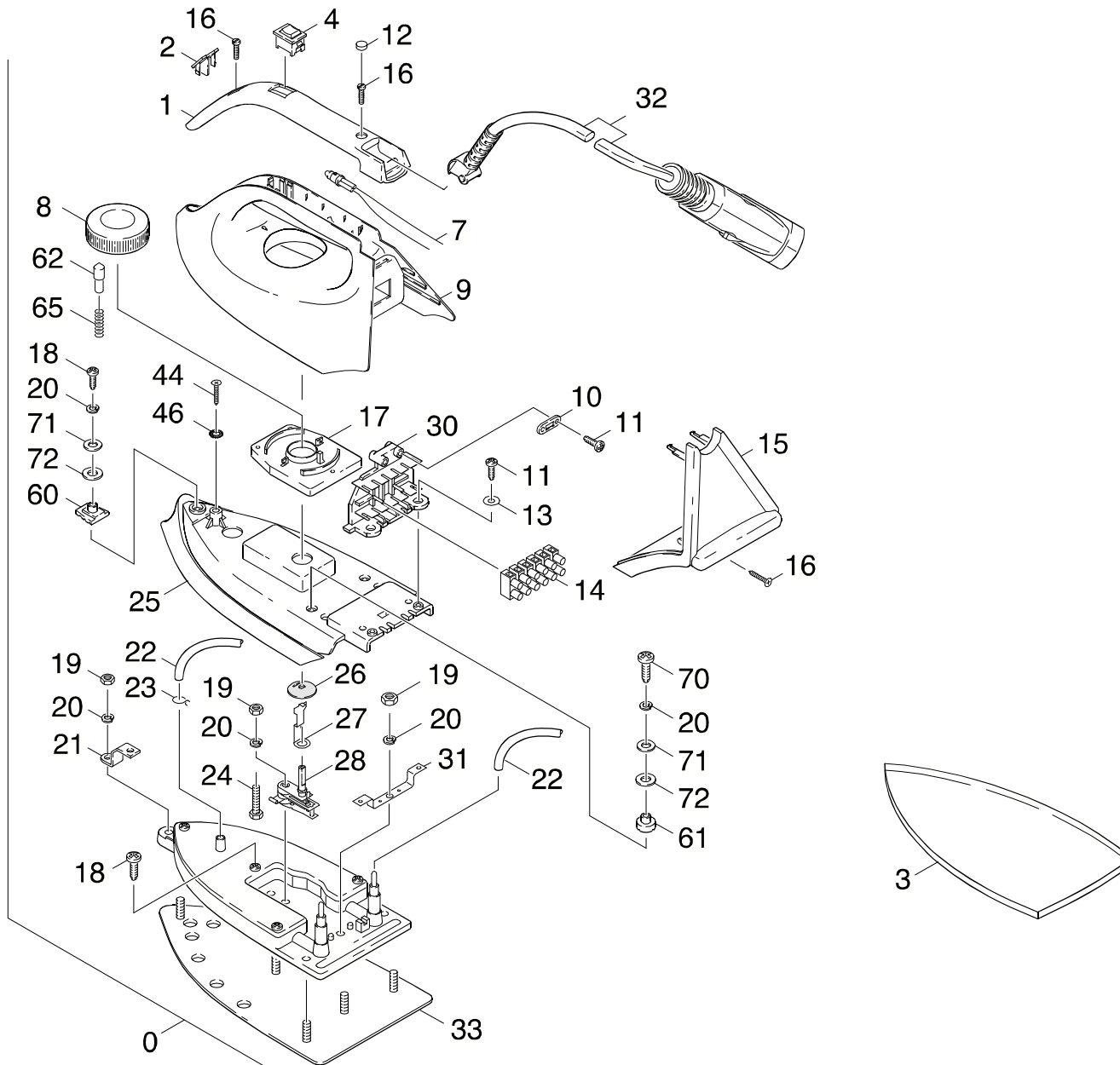

Symbolbeschreibung siehe M16 / symbol description see M16 / désignation de système voir M16 /

GRUPPE: 9.3 BUEGELEISEN / VERSION 3 /
 GROUP: 9.3 SMOOTHING IRON / VERSION 3 /
 GROUPE: 9.3 FER A REPASSER / VERSION 3 /

G9

VAP K 1701

POS. ITM. POS.	BENNENUNNG DESCRIPTION DESIGNATION	TEILE-NR. PART-NO. NO.PIECE	STCK QTY. NBR.	POS. ITM. POS.	BENNENUNNG DESCRIPTION DESIGNATION	TEILE-NR. PART-NO. NO.PIECE	STCK QTY. NBR.
0	BUEGELEISEN M.VERP. / SMOOTHING IRON / FER A REPASSER	4.862-060.0	1	46	FAECHERSCHEIBE A4,3 / SERRATED LOCK WASHER / RONDELLE A EVENTAIL	7.312-230.0	1
1	ABDECKUNG / COVER / CHAPEAU	5.031-606.0	1	60	ABDECKUNG / COVER / CHAPEAU	5.031-616.0	1
2	ABDECKUNG / COVER / CHAPEAU	5.031-607.0	1	61	ABDECKUNG / COVER / CHAPEAU	5.031-617.0	2
3	BUEGELSOHLE KPL. / IRONING BOTTOM / BUEGELSOHLE KPL.	2.860-132.0	1	62	STIFT / PIN / CHEVILLE	5.314-096.0	1
	TEFLON/TEFLON/TEFLON			64	SCHLAUCHNIPPEL / HOSE STEM / RACCORD DE FLEXIBLE	5.443-454.0	1
4	SCHALTER / SWITCH / INTERRUPTEUR	6.630-096.0	1	65	FEDER / SPRING / RESSORT	5.332-443.0	1
5	KNICKSCHUTZ / BEND PROTECTION / ANTICOQUE	5.394-525.0	1	70	SCHNEIDSCHR. M4X 20 / SELF-TAPPING SCREW / VIS AUTOTARAUDEUSE	6.303-067.0	2
7	LEUCHTE / LAMP / LAMPE	6.651-407.0	1	71	SCHEIBE 4 / WASHER / RONDELLE	7.312-281.0	3
8	REGULIERRAD / CONTROL WHEEL / VOLANT DE REGULATION	5.031-608.0	1	72	SCHEIBE / WASHER / RONDELLE	5.115-800.0	3
9	GEHAEUSE / HOUSING / BOITIER	5.060-755.0	1				
10	ZUGENTLASTUNG / PULL RELIEF / DECHARGE DETRACTION	5.031-609.0	1				
11	LINSENSCHR. 2,9X 16 / OVAL HEAD SCREW / VIS A TETE BOMBEE	6.303-262.0	4				
12	STOPFEN / PLUG / BOUCHON	5.132-130.0	1				
13	SCHEIBE / WASHER / RONDELLE	5.115-661.0	2				
14	KLEMMLEISTE / STRIP TERMINAL / BORNE PLATE	6.634-210.0	1				
15	DECKEL / COVER / COUVERCLE	5.031-610.0	1				
16	LINSENSCHR. 3,0X 14 / OVAL HEAD SCREW / VIS A TETE BOMBEE	6.303-166.0	5				
17	PLATTE / PLATE / PLAQUE	5.006-042.0	1				
18	SCHRAUBE M 4X 16 / SCREW / VIS	7.303-033.0	5				
19	6KT-MUTTER M 4 / HEXAGON NUT / ECROU HEXAGONAL	7.311-001.0	6				
20	FEDERRING B 4 / SPRING WASHER / RONDELLE GROWER	7.313-001.0	9				
21	BUEGEL / STRAP / ETRIER	5.034-574.0	1				
22	SCHLAUCH / HOSE / TUYAU FLEXIBLE	6.390-299.0	3				
23	SCHLAUCHSCHELLE / HOSE BAND CLIP / COLLIER DE SERRAGE	6.389-567.0	1				
24	6KT-SCHR. M 4X 35 / HEXAGONAL HEAD SCREW / VIS HEXAGONAL	7.304-043.0	1				
25	GEHAEUSE / HOUSING / BOITIER	5.060-756.0	1				
26	ABDECKUNG / COVER / CHAPEAU	5.031-611.0	1				
27	MITNEHMER / CARRIER / ENTRAINEUR	5.474-025.0	1				
28	TEMPERATURREGLER / THERMOSTAT / THERMOSTAT	6.690-099.0	1				
30	HALTER / BRACKET / FIXATION	5.044-183.0	1				
31	BUEGEL / STRAP / ETRIER	5.034-575.0	1				
32	SCHLAUCH BE / HOSE / TUYAU FLEXIBLE	4.400-009.0	1				
33	BUEGELSOHLE / IRONING BOTTOM / BUEGELSOHLE	5.862-002.0	1				
44	BL.SCHR. ST3,5X16,0 / SHEET METAL SCREW / VIS A TOLE	7.303-363.0	1				

"=> xxxxxx" = bis Werknummer / up to serial No. / jusqu' au No. de fabr. / "xxxxxx =>" = ab Werknummer / from serial No. / a partir du No. de fabr. /

GRUPPE: 9.4 BUEGELEISEN / VERSION 4 /
GROUP: 9.4 SMOOTHING IRON / VERSION 4 /
GROUPE: 9.4 FER A REPASSER / VERSION 4 /

H9

VAP K 1701

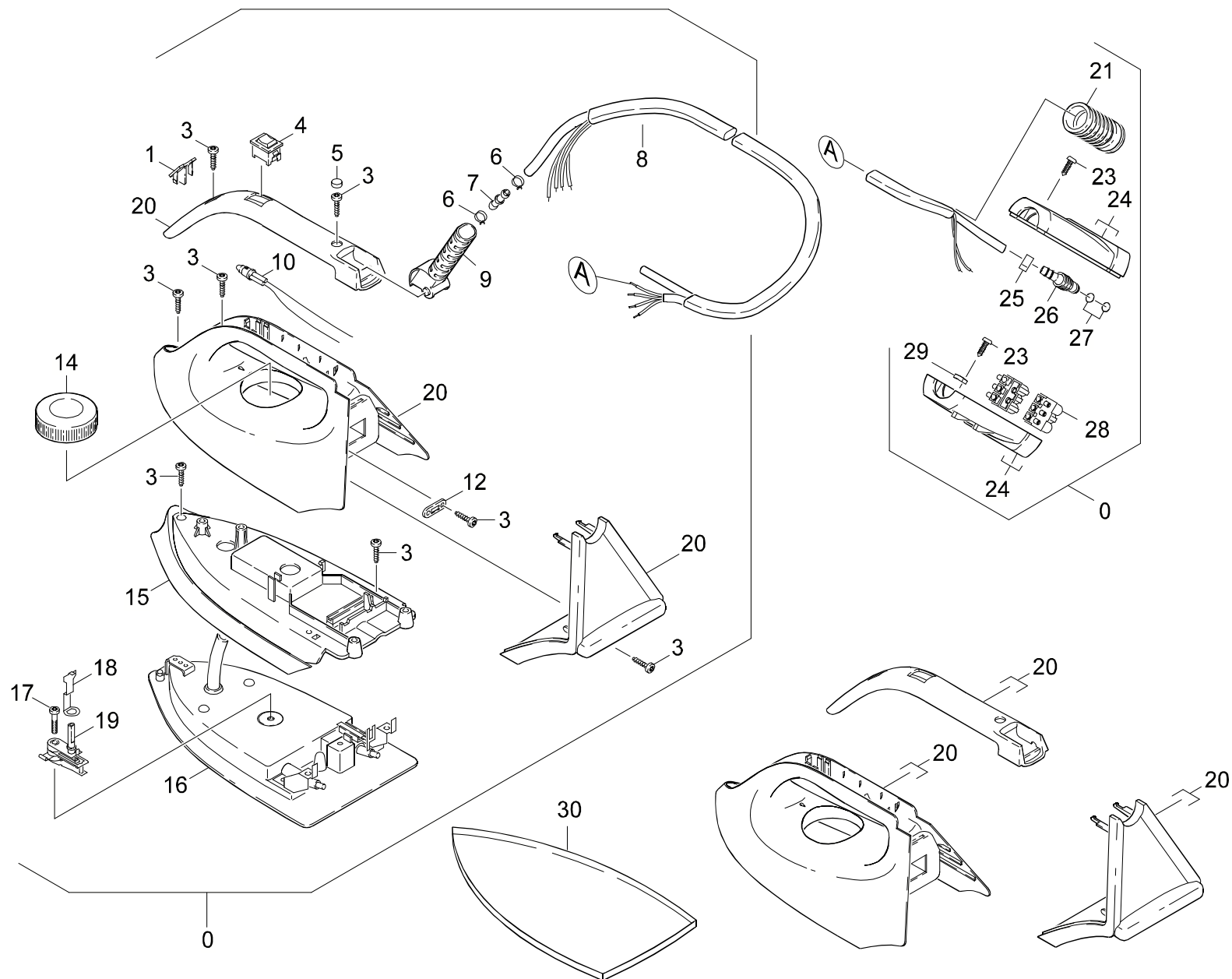

Symbolbeschreibung siehe M16 / symbol description see M16 / désignation de système voir M16 /

GRUPPE: 9.4 BUEGELEISEN / VERSION 4 /
GROUP: 9.4 SMOOTHING IRON / VERSION 4 /
GROUPE: 9.4 FER A REPASSER / VERSION 4 /

19

VAP K 1701

POS. ITM. POS.	BENNENUNG DESCRIPTION DESIGNATION	TEILE-NR. PART-NO. NO.PIECE	STCK QTY. NBR.
0	BUEGELEISEN M.VERP. / SMOOTHING IRON / FER A REPASSER	4.862-060.0	1
1	LAMPENABDECKUNG / COVER / COUVERCLE	6.998-041.0	1
3	SCHRAUBE 3,5X16 / SCREW / VIS	6.998-043.0	10
4	MIKROSCHALTER / MICRO SWITCH / MICRORUPTEUR	5.744-020.0	1
5	KAPPE / CAP / CAPUCHON	6.998-045.0	1
6	SHELLE / CLAMP / COLLIER	6.992-085.0	1
7	DOPPELNIPPEL / DOUBLE NIPPLE / NIPPLE DOUBLE	6.998-047.0	1
8	DAMPFSCHLAUCH / STEAM HOSE / TUYAU FLEXIBLE (VAPEUR)	4.321-123.0	1
9	KNICKSCHUTZ / BEND PROTECTION / ANTICOQUE	5.394-525.0	1
10	LAMPE / LAMP / LAMPE	6.998-049.0	1
12	ZUGENTLASTUNG / PULL RELIEF / DECHARGE DETRACTION	6.998-051.0	1
14	VERSTELLRAD / ADJUSTING WHEEL / ROUE REGL.	5.116-067.0	1
15	FORMTEIL / MOULDED PART / PREFORME	6.998-054.0	1
16	BUEGELSOHLE 230/700 / IRONING BOTTOM / BUEGELSOHLE 230/700	6.998-055.0	1
17	SCHRAUBE 4X25 / SCREW / VIS	6.998-056.0	1
18	MITNEHMER / CARRIER / ENTRAINEUR	6.998-057.0	1
19	TEMPERATURREGLER / THERMOSTAT / THERMOSTAT	6.998-058.0	1
20	GEHAEUSE KPL. / HOUSING / BOITIER	4.060-520.0	1
21	SCHUTZTEIL / PROTECTION PART / PARTIE PROTECTEUR	5.394-374.0	1
23	LINSENSCHR. 3,0X 14 / OVAL HEAD SCREW / VIS A TETE BOMBEE	6.303-166.0	1
24	STECKER (SCHALEN) / PLUG / FICHE	5.031-060.0	1
25	SCHLAUCHSHELLE / HOSE BAND CLIP / COLLIER DE SERRAGE	6.389-992.0	1
26	KOLBEN / PISTON / PISTON	5.553-339.0	1
27	O-RING 6,75X 1,78 / GASKET / BAQUE D'ETANCHEITE	6.362-923.0	1
28	STECKERTEIL / PLUG ELEMENT / PIECE CONNECTEUR	6.646-325.0	1
29	ZUGENTLASTUNG / PULL RELIEF / DECHARGE DETRACTION	6.647-513.0	1
30	BUEGELSOHLE KPL. / IRONING BOTTOM / BUEGELSOHLE KPL.	2.860-132.0	1

"=> xxxxxx" = bis Werknummer / up to serial No. / jusqu' au No. de fabr. / "xxxxxx =>" = ab Werknummer / from serial No. / a partir du No. de fabr. /

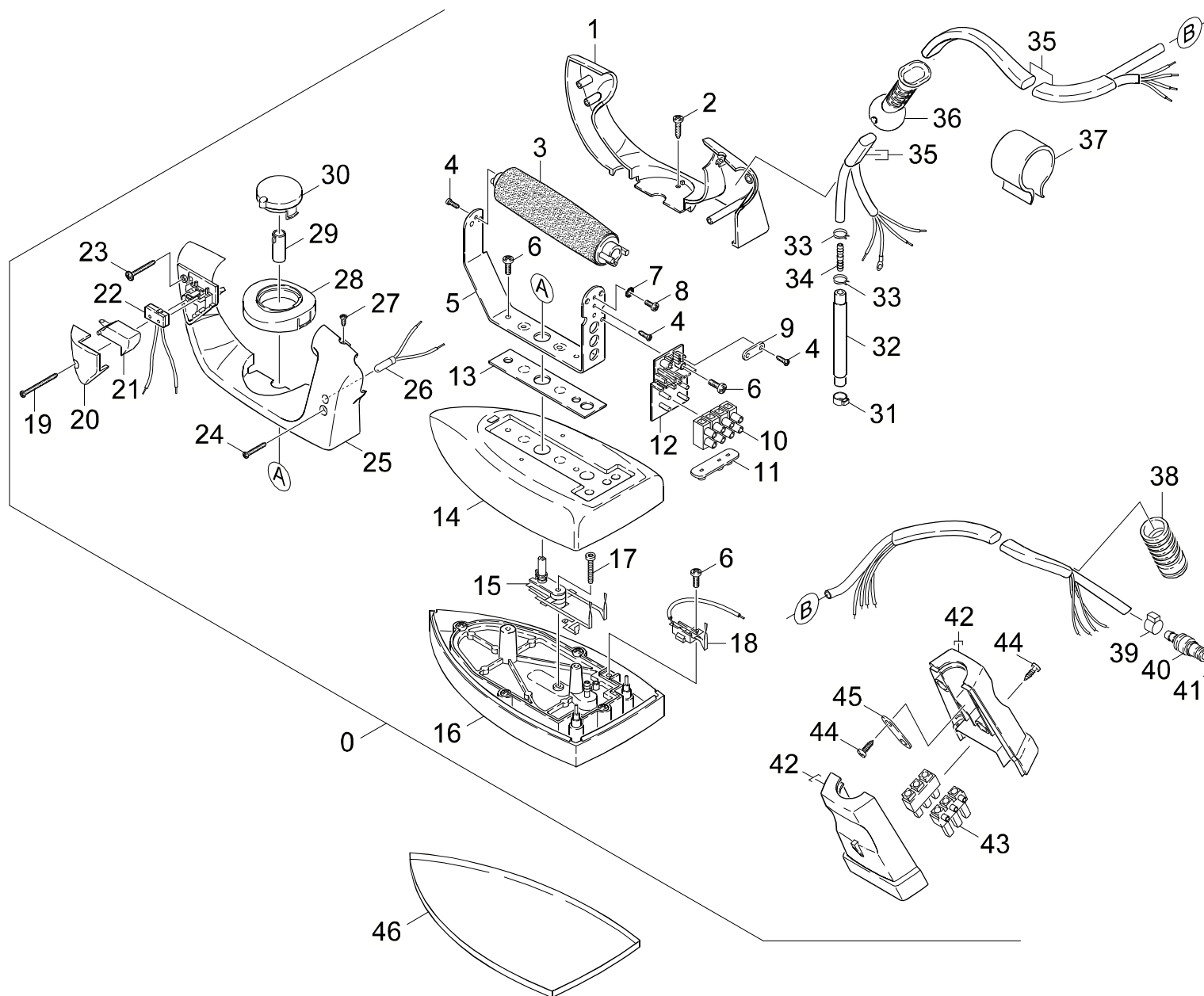

Symbolbeschreibung siehe M16 / symbol description see M16 / désignation de système voir M16 /

GRUPPE: 9.5 BUEGELEISEN / VERSION 5 /
 GROUP: 9.5 SMOOTHING IRON / VERSION 5 /
 GROUPE: 9.5 FER A REPASSER / VERSION 5 /

K9

VAP K 1701

POS. ITM. POS.	BENNENNUNG DESCRIPTION DESIGNATION	TEILE-NR. PART-NO. NO.PIECE	STCK QTY. NBR.	POS. ITM. POS.	BENNENNUNG DESCRIPTION DESIGNATION	TEILE-NR. PART-NO. NO.PIECE	STCK QTY. NBR.
0	BE 7001 230/240V / SMOOTHING IRON / FER A REPASSER	4.862-105.0	1	38	SCHUTZTEIL / PROTECTION PART / PARTIE PROTECTEUR	5.394-374.0	1
1	GRIFFTeil RECHTS / HANDLE PART / POIGNEE	6.992-022.0	1	39	SCHLAUCHSCHELLE / HOSE BAND CLIP / COLLIER DE SERRAGE	6.389-992.0	1
2	SCHRAUBE 3,5X16 / SCREW / VIS	6.998-043.0	1	40	KOLBEN / PISTON / PISTON	5.553-339.0	1
3	GRIF / HANDLE / POIGNEE	6.992-016.0	1	41	O-RING 6,75X 1,78 / GASKET / BAQUE D'ETANCHEITE	6.362-923.0	2
4	BLECHSCHRAUBE / SELF-TAPPING SCREW / VIS A TOLE	6.992-027.0	2	42	STECKER (SCHALEN) / PLUG / FICHE	5.031-060.0	1
5	STUETZHALTER / SAFETY SUPPORT / APPUI-SUPPORT	6.992-020.0	1	43	STECKERTEIL / PLUG ELEMENT / PIECE CONNECTEUR	6.646-325.0	2
6	SCHRAUBE 4X12 / SCREW / VIS	6.992-028.0	2	44	LINSENSCHR. 2,9X 13 / OVAL HEAD SCREW / VIS A TETE BOMBEE	6.303-058.0	5
7	ZAHNSCHEIBE 4,2 / LOCK WASHER / ROUE PLATE	6.992-029.0	1	45	ZUGENTLASTUNG / PULL RELIEF / DECHARGE DETRACTION	6.647-513.0	1
8	SCHRAUBE 3,5X8 / SCREW / VIS	6.992-030.0	1	46	BUEGELSOHLE KPL. / IRONING BOTTOM / BUEGELSOHLE KPL.	2.860-131.0	1
9	ZUGENTLASTUNG / PULL RELIEF / DECHARGE DETRACTION	6.998-051.0	1		TEFLON/TEFLON/TEFLON		
10	KLEMMENLEISTE / STRIP TERMINAL / BORNE PLATE	6.992-006.0	1				
11	SCHUTZ / PROTECTION / PROTECTION	6.992-018.0	1				
12	TRAEGER / CARRIER / LONGERON	6.992-008.0	1				
13	SCHLAUCHSCHELLE / HOSE BAND CLIP / COLLIER DE SERRAGE	6.992-019.0	1				
14	ABDECKUNG / COVER / CHAPEAU	6.992-017.0	1				
15	TEMPERATURREGLER / THERMOSTAT / THERMOSTAT	6.998-058.0	1				
16	GRUNDPLATTE / BASE PLATE / PLAQUE DE BASE	6.992-001.0	1				
17	SCHRAUBE 4X25 / SCREW / VIS	6.992-032.0	1				
19	BLECHSCHRAUBE / SELF-TAPPING SCREW / VIS A TOLE	6.992-034.0	1				
20	ABDECKUNG / COVER / CHAPEAU	6.992-023.0	1				
21	SCHALTER / SWITCH / INTERRUPTEUR	6.992-012.0	1				
22	MIKROSCHALTER / MICRO SWITCH / MICRORUPTEUR	6.992-005.0	1				
23	BLECHSCHRAUBE / SELF-TAPPING SCREW / VIS A TOLE	6.992-035.0	1				
24	BLECHSCHRAUBE / SELF-TAPPING SCREW / VIS A TOLE	6.992-036.0	1				
25	GRIFFTeil LINKS / HANDLE PART / POIGNEE	6.992-009.0	1				
26	SIGNALLEUCHE / PILOT LAMP / LAMPE TEMOIN	6.992-011.0	1				
27	BLECHSCHRAUBE / SELF-TAPPING SCREW / VIS A TOLE	6.992-037.0	1				
28	WAEHLSCHEIBE / DIAL DISK / CARDAN D'APPEL	6.992-013.0	1				
29	VERBINDUNG / CONNECTION / RACCORD	6.992-014.0	1				
30	REGULIERRAD / CONTROL WHEEL / VOLANT DE REGULATION	6.992-015.0	1				
31	SCHLAUCHSCHELLE / HOSE BAND CLIP / COLLIER DE SERRAGE	6.992-021.0	1				
32	SCHLAUCH MIT HUELSE / HOSE / TUYAU FLEXIBLE	6.992-024.0	1				
33	SCHELLE / CLAMP / COLLIER	6.992-085.0	2				
34	DOPPELNIPPEL / DOUBLE NIPPLE / NIPPLE DOUBLE	6.992-007.0	1				
35	KABEL / CABLE / CABLE	6.992-003.0	1				
36	KNICKSCHUTZTUELLE / BEND PROTECTION SPOUT / PASSE-CABLE	6.992-004.0	1				

"=> xxxxxx" = bis Werknummer / up to serial No. / jusqu' au No. de fabr. / "xxxxxx =>" = ab Werknummer / from serial No. / a partir du No. de fabr. /

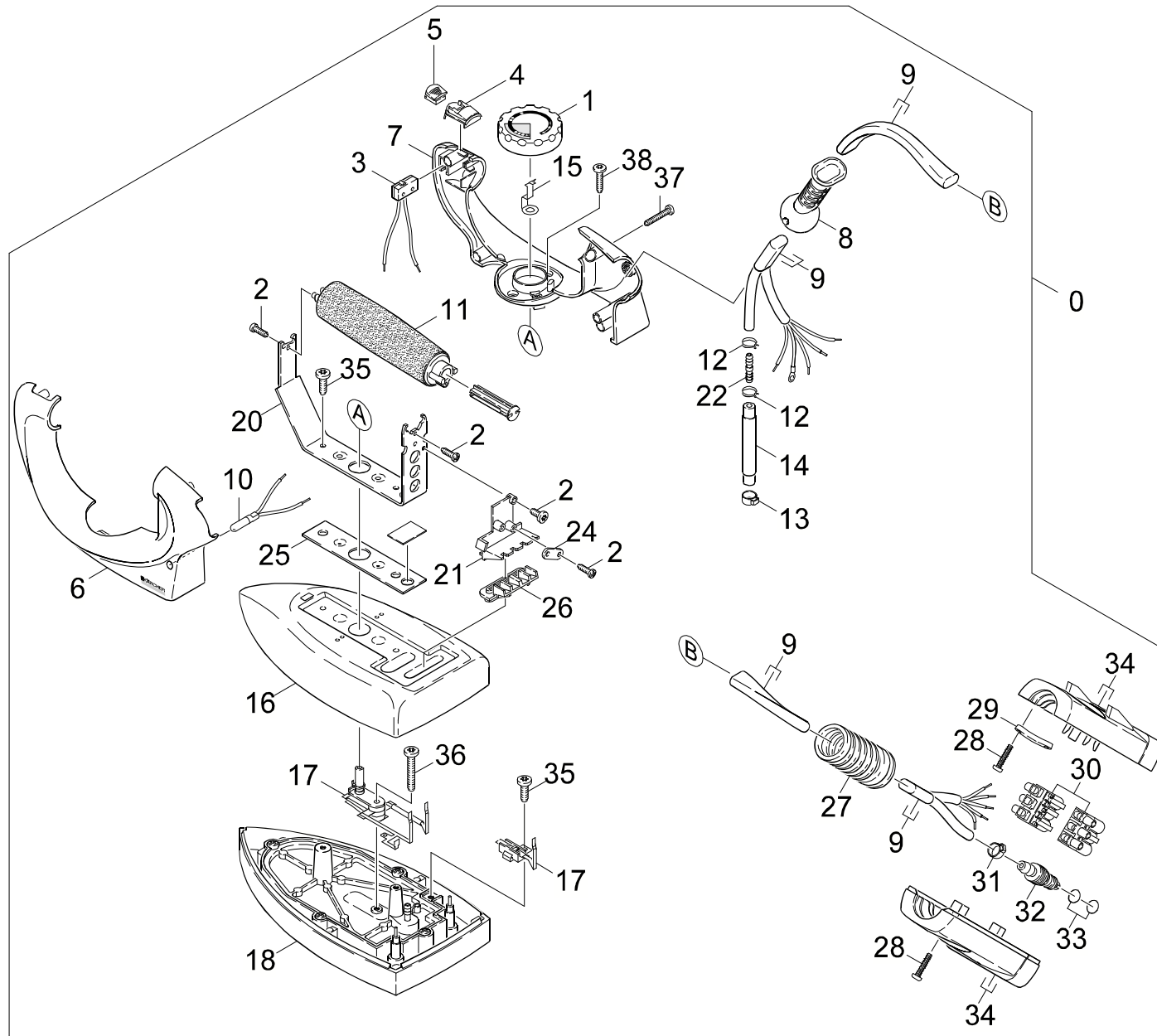

Symbolbeschreibung siehe M16 / symbol description see M16 / désignation de système voir M16 /

GRUPPE: 9.6 BUEGELEISEN / VERSION 6 /
 GROUP: 9.6 SMOOTHING IRON / VERSION 6 /
 GROUPE: 9.6 FER A REPASSER / VERSION 6 /

M9

VAP K 1701

POS. ITM. POS.	BENNENNUNG DESCRIPTION DESIGNATION	TEILE-NR. PART-NO. NO.PIECE	STCK QTY. NBR.	POS. ITM. POS.	BENNENNUNG DESCRIPTION DESIGNATION	TEILE-NR. PART-NO. NO.PIECE	STCK QTY. NBR.
0	BE 7001 230/240V / SMOOTHING IRON / FER A REPASSER	4.862-105.0	1	38	SCHRAUBE 3,5X16 / SCREW / VIS	6.998-043.0	1
1	REGULIERRAD / CONTROL WHEEL / VOLANT DE REGULATION	6.992-038.0	1				
2	BLECHSCHRAUBE / SELF-TAPPING SCREW / VIS A TOLE	6.992-027.0	5				
3	MICROSCHALTER / MICRORUPTEUR / MICROINTERRUPTOR	6.992-039.0	1				
4	HEBEL / LEVER / LEVIER	6.992-040.0	1				
5	SCHIEBER / BOLT / VERROU	6.992-041.0	1				
6	GRIFFTEIL LINKS / HANDLE PART / POIGNEE	6.992-042.0	1				
7	GRIFFTEIL RECHTS / HANDLE PART / POIGNEE	6.992-043.0	1				
8	KNICKSCHUTZTUELLE / BEND PROTECTION SPOUT / PASSE-CABLE	6.992-004.0	1				
9	KABEL / CABLE / CABLE	6.992-045.0	1				
10	SIGNALLEUCHE / PILOT LAMP / LAMPE TEMOIN	6.992-046.0	1				
11	GRIFF KORK / HANDLE / POIGNEE	6.992-047.0	1				
12	SCHELLE / CLAMP / COLLIER	6.992-085.0	2				
13	SCHLAUCHSCHELLE / HOSE BAND CLIP / COLLIER DE SERRAGE	6.992-019.0	1				
14	SCHLAUCH MIT HUELSE / HOSE / TUYAU FLEXIBLE	6.992-024.0	1				
15	MITNEHMER / CARRIER / ENTRAINEUR	6.998-057.0	1				
16	ABDECKUNG / COVER / CHAPEAU	6.992-048.0	1				
17	THERMOSTAT / THERMOSTAT / THERMOSTAT	6.992-049.0	1				
18	GRUNDPLATTE / BASE PLATE / PLAQUE DE BASE	6.992-050.0	1				
20	STUETZHALTER / SAFETY SUPPORT / APPUI-SUPPORT	6.992-051.0	1				
21	TRAEGER / CARRIER / LONGERON	6.992-052.0	1				
22	DOPPELNIPPEL / DOUBLE NIPPLE / NIPPLE DOUBLE	6.992-007.0	1				
24	ZUGENTLASTUNG / PULL RELIEF / DECHARGE DETRACTION	6.998-051.0	1				
26	SCHUTZ / PROTECTION / PROTECTION	6.992-054.0	1				
27	SCHUTZTEIL / PROTECTION PART / PARTIE PROTECTEUR	5.394-374.0	1				
28	LINSENSCHR. 2,9X 13 / OVAL HEAD SCREW / VIS A TETE BOMBEE	6.303-058.0	5				
29	ZUGENTLASTUNG / PULL RELIEF / DECHARGE DETRACTION	6.647-513.0	1				
30	STECKERTEIL / PLUG ELEMENT / PIECE CONNECTEUR	6.646-325.0	2				
31	SCHLAUCHSCHELLE / HOSE BAND CLIP / COLLIER DE SERRAGE	6.389-992.0	1				
32	KOLBEN / PISTON / PISTON	5.553-339.0	1				
33	O-RING 6,75X 1,78 / GASKET / BAQUE D'ETANCHEITE	6.362-923.0	2				
34	STECKER (SCHALEN) / PLUG / FICHE	5.031-060.0	1				
35	SCHRAUBE 4X12 / SCREW / VIS	6.992-028.0	1				
36	SCHRAUBE 4X25 / SCREW / VIS	6.992-032.0	1				
37	BLECHSCHRAUBE / SELF-TAPPING SCREW / VIS A TOLE	6.992-036.0	1				

"=> xxxxxx" = bis Werknummer / up to serial No. / jusqu' au No. de fabr. / "xxxxxx =>" = ab Werknummer / from serial No. / a partir du No. de fabr. /

GRUPPE: 10.0TAPETENLOESER
GROUP: 10.0NOZZLE FOR HANGINGS
GRUPPE: 10.0BUSE DETAPISSEUR

A10

VAP K 1701

GRUPPE: 10.0TAPETENLOESER
GROUP: 10.0NOZZLE FOR HANGINGS
GRUPPE: 10.0BUSE DETAPISSEUR

GRUPPE: 10.0TAPETENLOESER
GROUP: 10.0NOZZLE FOR HANGINGS
GRUPPE: 10.0BUSE DETAPISSEUR

B10

VAP K 1701

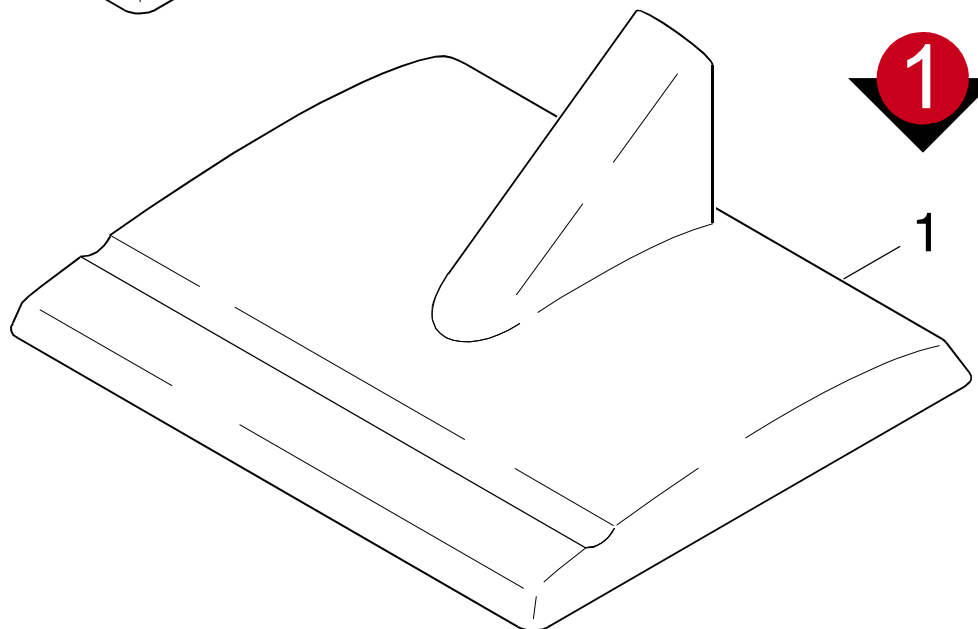
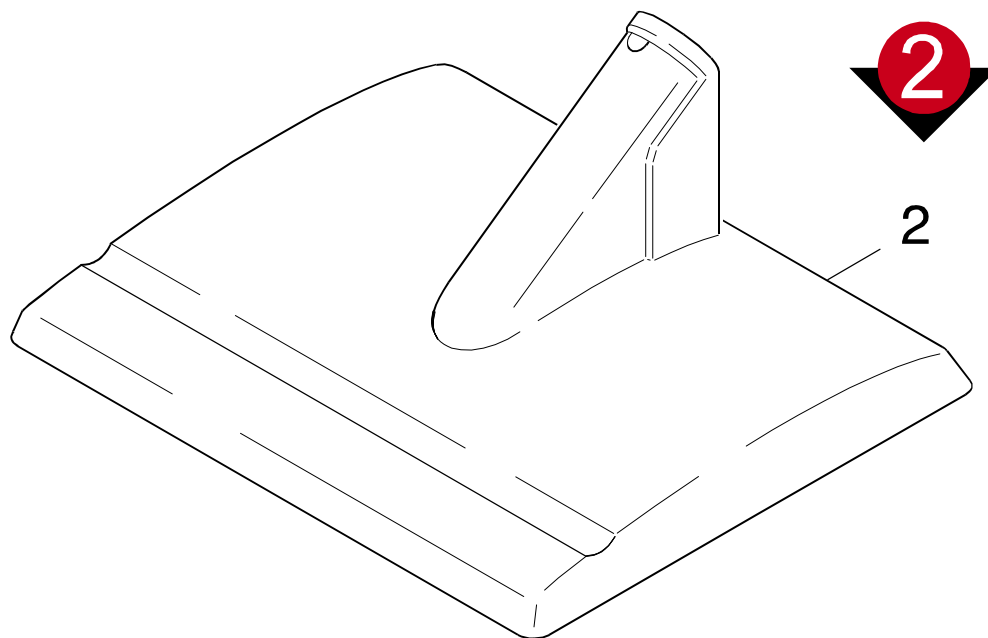

Symbolbeschreibung siehe M16 / symbol description see M16 / désignation de système voir M16 /

GRUPPE: 10.0TAPETENLOESER
GROUP: 10.0NOZZLE FOR HANGINGS
GROUPE: 10.0BUSE DETAPISSEUR

C10

VAP K 1701

POS.	BENNENNUNG	TEILE-NR.	STCK
ITM.	DESCRIPTION	PART-NO.	QTY.
POS.	DESIGNATION	NO.PIECE	NBR.

1	TAPETENLOESER / NOZZLE FOR HANGINGS / BUSE DETAPISSEUR VERSION 1	2.863-057.0	1
2	TAPETENLOESER / NOZZLE FOR HANGINGS / BUSE DETAPISSEUR VERSION 2	2.863-062.0	1

"=> xxxxxx" = bis Werknummer / up to serial No. / jusqu' au No. de fabr. / "xxxxxx =>" = ab Werknummer / from serial No. / a partir du No. de fabr. /

Bestellhinweis

Bei Ihrer Bestellung sind unbedingt anzugeben :

1.	2.	3.	4.	5.
Gerätetyp Machine model Type d'appareils	Herstell-Nr. Serial-No. No. de série	Benennung Description Désignation	Teile-Nr. Part No. Référence	Stückzahl Piece No. Quantité



**siehe Typenschild
see name-plate
voir plaque signalétique**



**siehe Ersatzteilliste
see spare parts list
voir liste des pièces de rechange**

- Die Ersatzteile, welche als Meterware geliefert werden, sind auf Einbaulänge selbst zu kürzen. Ebenso sind die Stückzahlen in den jeweiligen Gruppen als Mindestbestellmengen = 1m angegeben und können je nach Bedarf auf weitere volle Meterzahlen erhöht und bestellt werden.
- Spare Parts which are delivered as cut goods have to be shortened to installation length. The quotation of quantity in each group refers to the minimum order quantity = 1m and may be ordered and raised to further full metre-values according to demand
- Les pièces de rechange qui sont livrées comme marchandise au mètre sont à raccourcir selon la longueur d'installation. Les indications de quantité dans chaque group se réfèrent à des valeurs de mètre de plus.
- Diese Ersatzteilliste erscheint in gedruckter Form sowie als Mikrofiche. Bei Querverweisen bezieht sich die Angabe "Seitenzahl" auf die gedruckte Ersatzteilliste und die Angabe "Bildtafel" auf die Mikrofilmausgabe.
- This spare parts list is published both in printed form and as a microfiche. In the cross-references, "page number" refers to the printed spare parts list and "display table" to the microfilm edition.
- Cette liste de pièces de rechange est aussi bien imprimée que publiée sous forme de microfiche. Les indications transversales renvoient au "numéro de page" sur la liste imprimée des pièces de rechange et à la "planche" sur la microfiche.

Bitte beachten Sie, daß der Teileumfang dieser Ersatzteilliste nicht unbedingt dem Lieferumfang Ihres Gerätes entspricht.

For your information: It could be that certain parts quoted in this spare parts list were not included with the machine delivery.

Pour votre information: il se peut que certaines pièces détachées mentionnées sur la liste ne vous aient pas été livrées avec l'appareil.

Die in dieser Ersatzteilliste nicht aufgeführten Einzelteile, bestellen Sie bitte direkt beim Vertragskundendienst des jeweiligen Herstellers.

Please order the individual parts not included in this assembly directly with the contract aftersales service of the manufacturer in question.

Veillez s'il vous plaît, commander les pièces détachées qui ne sont indiquées dans notre liste des pièces détachées, directement auprès du service après-vente des fabricants en question.

Bei Bestellung von lackierten Teilen, welche in der Ersatzteilliste nicht in verschiedenen Farben ausgewiesen sind, ist zusätzlich die Farbnummer oder Farbe mit anzugeben. Diese finden Sie auf dem Typenschild oder Farbschild Ihres Gerätes.

Upon ordering of varnished parts which are not mentioned in the spare parts list as parts with different colors, kindly additionally mention the number of the color. It can be seen on the type plate of the color plate of your machine.

Commandant des parts vernissés qui ne sont pas mentionnés comme parts avec une couleur différente dans la liste des pièces détachées, veuillez mentionner de plus le numéro de la couleur. Il se trouve sur la plaque signalétique ou la plaque de couleur de votre machine.

Auflistungen von Einzelteilen bei Ersatzteil - u. Pumpensets sind in der Reihe "16" einzusehen, bzw. direkt unter dem entsprechenden Set aufgelistet.

Listings of single parts upon spare parts kits and pump kits can be seen in row "16" or directly listed below the corresponding kit.
Des établissements des pièces détachées en ce qui concerne les kits des pièces de rechange et les kits de pompes, peuvent être vus à la ligne "16" ou ils sont répertoriés directement au-dessous du jeu correspondant.

Technische Änderungen im Rahmen der Weiterentwicklung sowie das Recht der ausschließlichen Auswertung unseres geistigen Eigentums behalten wir uns vor. Vervielfältigung und Nachdruck nur mit Genehmigung und Urheberhinweis möglich.

We reserve the right to make technical changes in the course of development work and the right to make exclusive use of our intellectual property. This spare parts list may be duplicated or reprinted only with our approval and with acknowledgement of our copyright.

Nous nous réservons le droit de toutes modifications techniques dans le cadre du perfectionnement des mises au point ainsi que le droit de la mise en valeur exclusive de notre propriété intellectuelle. Polycopie et reproduction exclusivement après accord et avec mention de l'auteur.

INDEX

M16

VAP K 1701

GRUPPE: 1.0 GERAET-EINZELTEILE A1-G1
GROUP: 1.0 APPLIANCE - PIECE PARTS
GROUPE: 1.0 USTENSILE-PIECES CONSTIT.

GRUPPE: 2.0 DAMPFBEHAELTER A2-C2
GROUP: 2.0 STEAM DRUM
GROUPE: 2.0 VAPORIGENE

GRUPPE: 3.0 SCHLAUCH A3-C3
GROUP: 3.0 HOSE
GROUPE: 3.0 TUYAU FLEXIBLE

GRUPPE: 4.0 VERLAENGERUNG A4-C4
GROUP: 4.0 EXTENSION
GROUPE: 4.0 RALLONGE

GRUPPE: 5.0 BUERSTEN A5-C5
GROUP: 5.0 BRUSHES
GROUPE: 5.0 BROSSES

GRUPPE: 6.0 DUESE A6-C6
GROUP: 6.0 NOZZLE
GROUPE: 6.0 BUSE

GRUPPE: 7.0 FENSTERDUESE A7-C7
GROUP: 7.0 WINDOW TOOL
GROUPE: 7.0 SUCEUR POUR FENETRE

GRUPPE: 8.0 WASSERFILTER A8-C8
GROUP: 8.0 WATER FILTER
GROUPE: 8.0 FILTRE (EAU)

GRUPPE: 9.0 BUEGELEISEN A9-M9
GROUP: 9.0 SMOOTHING IRON
GROUPE: 9.0 FER A REPASSER

GRUPPE: 10.0 TAPETENLOESER A10-C10
GROUP: 10.0 NOZZLE FOR HANGINGS
GROUPE: 10.0 BUSE DETAPISSEUR

 BEISPIEL: VERSION 1
EXAMPLE: VERSION 1
EXEMPLE: VERSION 1

 BEISPIEL: SIEHE IN GRUPPE 3
EXAMPLE: SEE IN GROUP 3
EXEMPLE: VOIR EN GROUPE 3



WICHTIGER HINWEIS
IMPORTANT REMARK
REMARCAQUAGE IMPORTANT

BESTELLHINWEIS SIEHE M15
EXAMPLE ORDER SEE M15
EXEMPLE DE COMMANDE VOIR M15

VARIANTENÜBERSICHT SIEHE L16
VARIANTS SURVEY SEE L16
VUE D'ENSEMBLE DE VARIANTS VOIR L16