

TW 300 S TW 300 CAR

**Nilfisk
ALTO**

Why Compromise



Spare parts
Ersatzteile
Pièces détachées
Reservedele

303000007 - 2015-07-12 Ersatzteile unter www.glues.com

Clarke
TECHNOLOGY

Zeichenerklärung

Key to symbols

Légende

Symbol erklæring

Recommended spare parts

A-Parts:

High turning parts. Recommended stock size is: [Number of machines sold x 0.02] or minimum 1.

These parts are typical: Brushes, brooms, flaps, filters, squeegee blades, etc.

B-Parts:

Medium turning parts. Recommended stock size is: [Number of machines sold x 0.01] or minimum 1.

These parts are typical: Hydraulic valves, fuses, circuit breakers, seal kits, belts, carbon brushes, etc.

C-Parts:

Low turning parts. Recommended stock size is: Minimum 1.

These parts are typical: Electrical parts, relays, switches, motors, hoses, wheels, etc.

Empfohlene Ersatzteile

A-Teile:

Teile mit hoher Umschlagshäufigkeit. Empfohlene Lagerstückzahl: [Anzahl der verkauften Maschinen x 0,02] oder Minimum 1.

Diese Teile sind typisch: Bürsten aller Art, Filter, Staubklappen, Gummilamellen, etc.

B-Teile:

Teile mit mittlerer Umschlagshäufigkeit. Empfohlene Lagerstückzahl: [Anzahl der verkauften Maschinen x 0,01 oder Minimum 1.

Diese Teile sind typisch: Hydraulische Ventile, Sicherungen, Stromunterbrecher, Dichtungssätze, Riemen, Kohlebürsten, etc.

C-Teile:

Teile mit niedriger Umschlagshäufigkeit. Empfohlene Lagerstückzahl: Minimum 1.

Diese Teile sind typisch: Elektrische Teile, Relais, Schalter, Motoren, Schläuche, Räder, etc.

Liste de pièces à stocker

Pièces-A:

Pièces de rechange de la vitesse de rotation haute. Le stock conseillé est : [Nombre de machines achetées x 0,02] avec un minimum de 1.

Classiquement, ces pièces sont : Brosses, balais, volets, filtres, raclettes, etc.

Pièces-B:

Pièces de rechange de la vitesse de rotation moyenne. Le stock conseillé est : [Nombre de machines achetées x 0,01] avec un minimum de 1.

Classiquement, ces pièces sont : Hydrauliques, fusibles, coupe-circuits, kits joints, courroies, charbons, etc.

Pièces-C:

Pièces de rechange de la vitesse de rotation bas. Le stock conseillé est : Un minimum de 1.

Classiquement, ces pièces sont : Pièces électriques, relais, interrupteurs, moteurs, flexibles, roues, etc.

Anbefalede reservedele

A-Parts:

Dele med høj omsætningshastighed. Anbefalet lagerstørrelse: [Antal maskiner solgt x 0,02] eller minimum 1.

Disse dele er typisk: Skrubbearster, fejekoste, klapper, filters, suggummiblade, m.v.

B-Parts:

Dele med middel omsætningshastighed. Anbefalet lagerstørrelse: [Antal maskiner solgt x 0,01] eller minimum 1.

Disse dele er typisk: Hydrauliske ventiler, sikringer, automatsikringer, manchets kits, remme, kulbørster, m.v.

C-Parts:

Dele med lav omsætningshastighed. Anbefalet lagerstørrelse: Minimum 1.

Disse dele er typisk: Elektriske dele, relæer, kontakter, motorer, slanger, hjul, m.v.

- ◇ ACHTUNG! - Meterware - Bitte bei Bestellung gewünschte Länge angeben!
- ATTENTION! - Lengths in metres - Please indicate required length when ordering!
- ATTENTION! - Longueurs par mètre - Préciser la longueur à la commande!
- BEMÆRK! - Metervare - Ved bestilling venligst opgive den ønskede længde!

- * bestehend aus ● beinhaltet
- consisting of includes
- composé de inclus
- bestående af inkludere

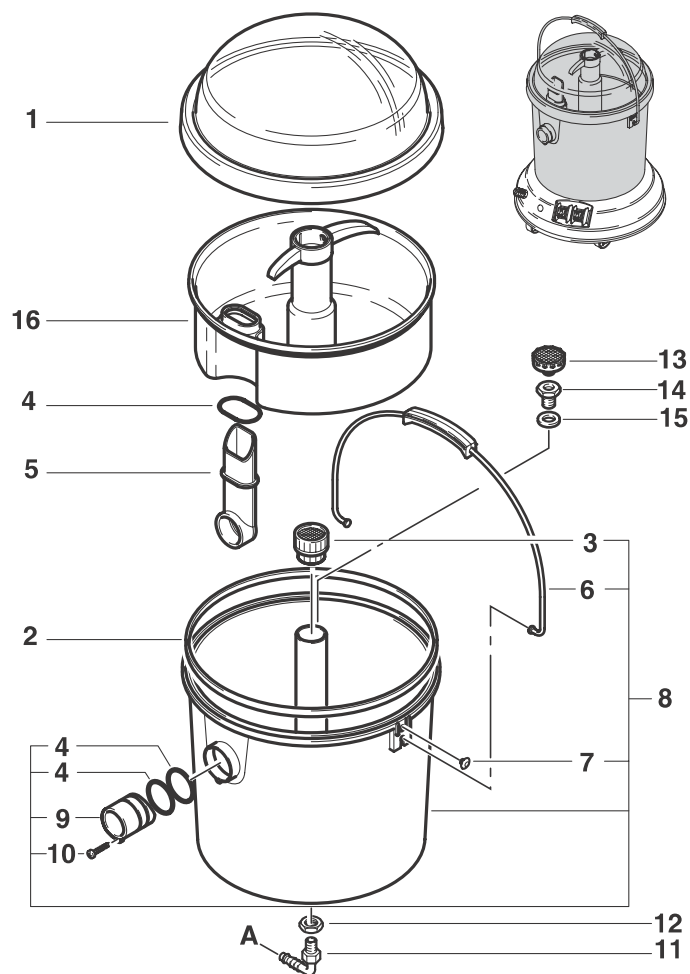

TW 300 S, TW 300 CAR-101-S

Pos.	No.	Description	Bezeichnung	Comment Bemerkung Bemærkning	Rec. Part		
					TW 300 S	TW 300 CAR	
1	7211	Cover	Haube			1	1
2	48323	Packing Ring 290x7,5x8	Dichtring 290x7,5x8			1	1
3	48324	Strainer Ø40	Sieb Ø40		C	1	1
4	4643	O-ring Ø38x3	O-Ring Ø38x3			3	3
5	7350	Spray Jet Bent	Sprühbogen			1	1
6	48325	U-Bracket	Bügel			1	1
7	48326	Buffer Ø6x10	Puffer Ø6x10			2	2
8	67081	Container	Behälter			1	1
9	46766	Inlet Fitting	Einlassfitting			1	1
10	3351	Screw 3,5x16	Blechschrabe 3,5x16			1	1
11	7356	Hose Liner Ø8 R1/4	Schlauchülle Ø8 R1/4			1	1
12	7393	Hexagon Nut R3/8x5	Sechskantmutter R3/8x5			1	1
13	7282	Filter Ø40	Filter Ø40		C	1	1
14	15629	Nipple	Sechskant-Hohnippel			1	1
15	7279	Packing Ring Ø17x2xØ32	Dichtring Ø17x2xØ32			1	1
16	7342	Waste Water Tank	Schmutzwassertank			1	1

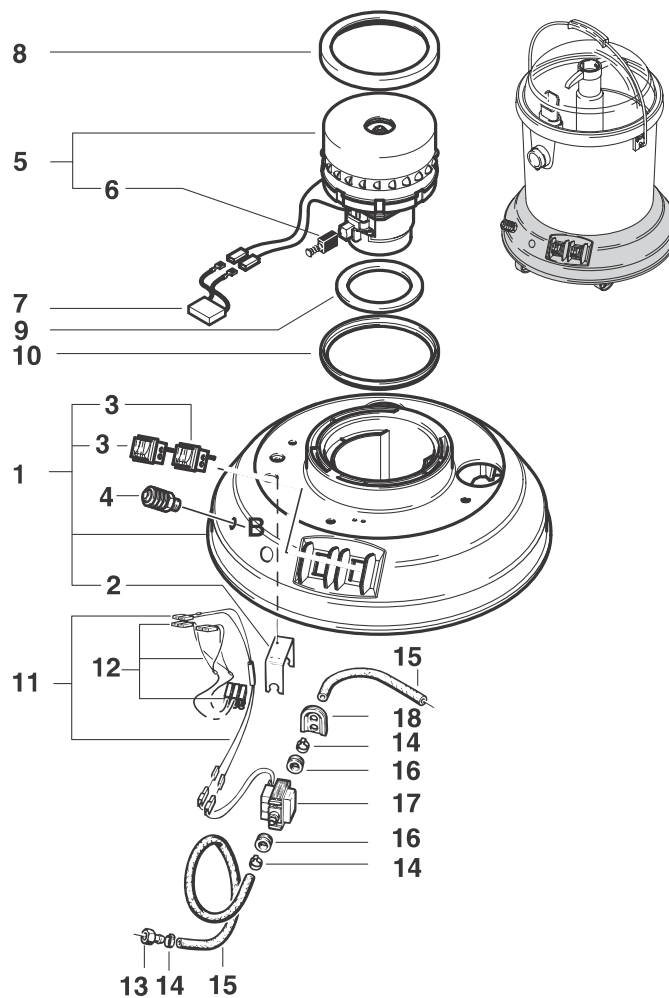

TW 300 S, TW 300 CAR-102-S

Pos.	No.	Description	Bezeichnung	Comment Bemerkung Bemærkning	Rec. Part	TW 300 S	TW 300 CAR
1	67083	Housing	Gehäuse			1	1
2	7386	Bracket	Haltebügel			1	1
3	43989	Switch 0-1/16(8)A	Wippschalter 0-1/16(8)A			2	2
4	7354	Coupling 1/4"	Kupplung 1/4"			1	1
5	11487	Motor 230V 1000W	Motor 230V 1000W		C	1	1
6	15762	Carbon Brush Set A	Kohlebürsten-Set A		C	1	1
7	7225	Filter Capacitor 0.1 MF	Entstörkondensator 0,1 MF		C	1	1
8	31843	Gasket	Motordichtring			1	1
9	15712	Packing Ring 78x105x10	Dichtring 78x105x10			1	1
10	31844	Gasket	Motordichtring			1	1
11	7389	Cable Lead Wire w. Diodes	Kabelbaum mit Dioden		C	1	1
12	34042	Cable Lead	Kabelbaum			1	1
13	7355	Hose Liner Ø8 R1/4	Schlauchtülle Ø8 R1/4			1	1
14	7239	Hose Clip Ø14,5	Schlauchschelle Ø14,5			3	3
◇	15	4973	Hose Ø6x3	Schlauch Ø6x3		1	1
16	7385	Retaining Ring	Halterungsring			2	2
17	7343	Spray Pump	Sprühpumpe		C	1	1
18	7395	Rubber Spout 42x45	Tülle 42x45			1	1

303000007 - 2005-07-12

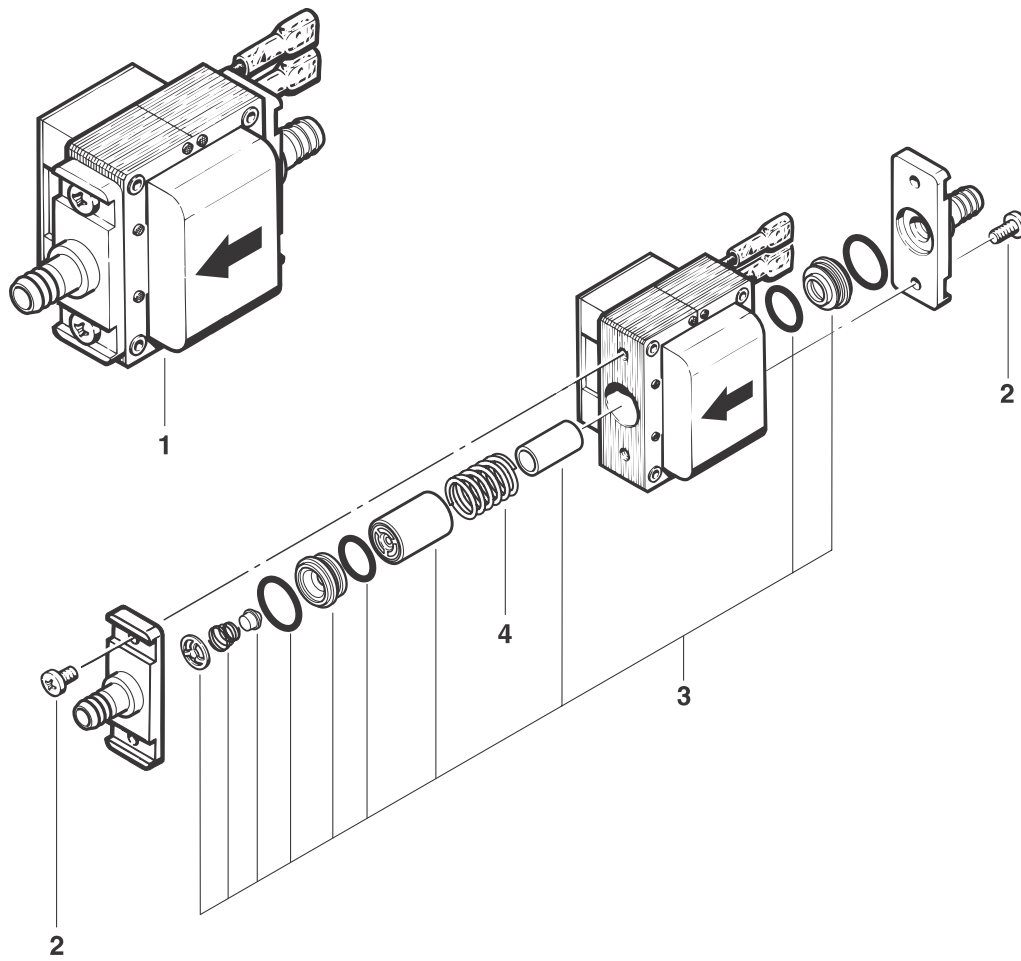

TW 300 S, TW 300 CAR-105-S

Pos.	No.	Description	Bezeichnung	Comment Bemerkung Bemærkning	Rec. Part	TW 300 S	TW 300 CAR
					C	1	1
1	7343	Spray Pump	Sprühpumpe		C	1	1
2	46269	Screw M4x10	Flachkopfschraube M4x10			4	4
3	34049	Repair Kit	Rep.Satz Wasserpumpe		B	1	1
4	909100089	Spring 1,7x14,6x20	Druckfeder 1,7x14,6x20		C	1	1

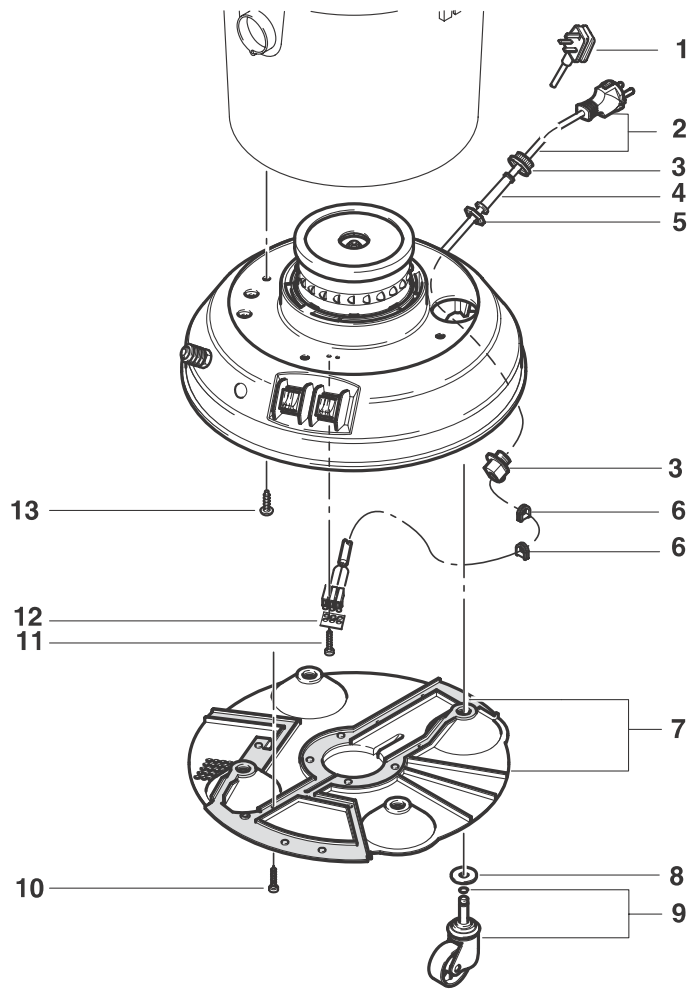

TW 300 S, TW 300 CAR-106-S

Pos.	No.	Description	Bezeichnung	Comment Bemerkung Bemærkning	Rec. Part	TW 300 S	TW 300 CAR
1	302000566	Power Cord H07RN-F 2x1x8,05 *GB*	Netzleitung H07RN-F 2x1x8,05 *GB*	*GB*		1	1
2	26771	Power Cord H05VV-F2x1x7,5	Netzleitung H05VV-F2x1x7,5	*EU*		1	1
3	7309	Cable Fixation PG9	Zugentlastung PG9			1	1
4	7352	Cable Grommet	Knickschutzhülse			1	1
5	1458	Nut 6KT PG 9	Sechskantmutter PG 9			1	1
6	48358	Cable Bushing 14x16	Kabelhülse 14x16			2	2
7	31282	Bottom Plate	Bodenplatte			1	1
8	4827	Washer 10,5x2,5	Scheibe 10,5x2,5			4	4
9	7228	Guide Roller Ø50	Lenkrolle Ø50			4	4
10	2791	Screw 2,9x16	Blechschrabe 2,9x16			7	7
11	5188	Screw 2,9x16	Blechschrabe 2,9x16			2	2
12	7146	Label	Klebeschild			1	1
13	10028	Screw 5x14	Schraube 5x14			4	4

TW 300 S
TW 300 CAR = Option

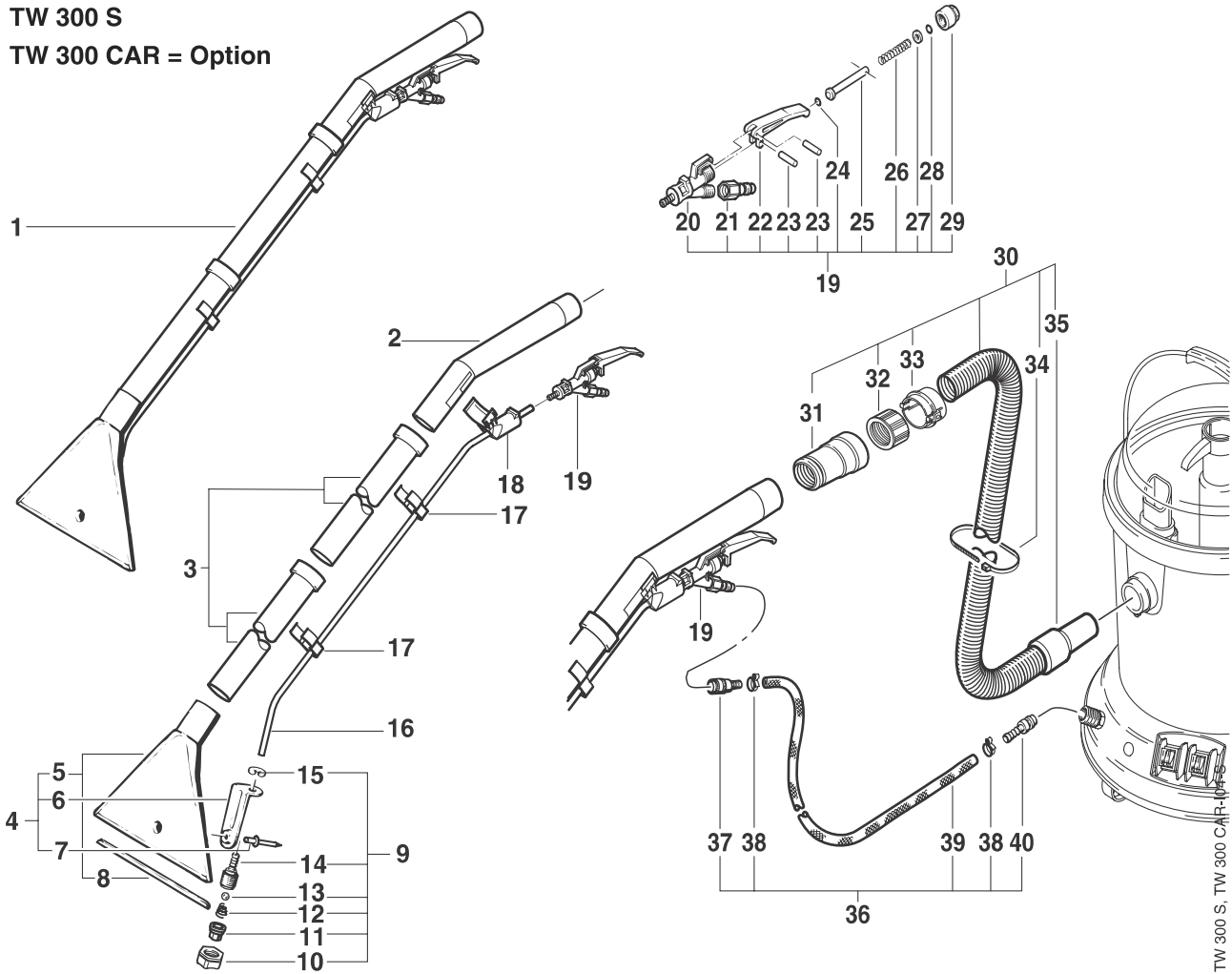

Pos.	No.	Description	Bezeichnung	Comment Bemerkung Bemærkning	Rec. Part	TW 300 S	TW 300 CAR
1	7310	Carpet Adaptor 26 cm	Teppichadapter 26 cm			1	
2	34475	Hand Tube	Handrohr			1	
3	15546	Suction Pipe Ø36x1000 Set [2] Stainless	Saugrohr Ø36x1000 Set [2] VA			1	
4	34472	Suction Nozzle	Saugdüse			1	
5	34473	Carpet Adaptor	Saugdüse			1	
6	7247	Bracket	Halterung			1	
7	15792	Rivet A4,8x16x15	Niet A4,8x16x15			1	
8	7245	Slide Rails for Carpet	Teppichgleitschiene			1	
9	34476	Spray Nozzle	Sprühdüsengarnitur			1	
10	7365	Cap Nut G3/8"	Überwurfmutter G3/8"			1	
11	7364	Nozzle	Sprühdüse		C	1	
12	34477	Spring	Druckfeder			1	
13	34478	Ball	Kugel			1	
14	34479	Nozzle Holder	Düsenhalter			1	
15	34480	Retaining Washer D9	Sicherungsscheibe D9			1	
16	28090	Chemical Tube Ø6x1x1130	Sprühschlauch Ø6x1x1130			1	
17	48375	Hose Clip	Schlauchhaltespanne			2	
18	34481	Mounting	Aufnahme			1	
19	7379	Lever	Hebelventil	consisting of 20 - 29		1	
20	34482	Valve Body	Ventilkörper		C	1	
21	7369	Coupler Nipple 1/4	Kupplungsniessel 1/4			1	
22	7399	Lever	Ventilhebel			1	
23	7401	Cylindrical Pin 1,5x14	Zylinderstift 1,5x14			2	
24	3001633	O-ring Ø5,3x2,4	O-Ring Ø5,3x2,4			1	
25	7400	Valve Pin	Ventilstift			1	

303000007 - 2005-07-12

TW 300 S
TW 300 CAR = Option

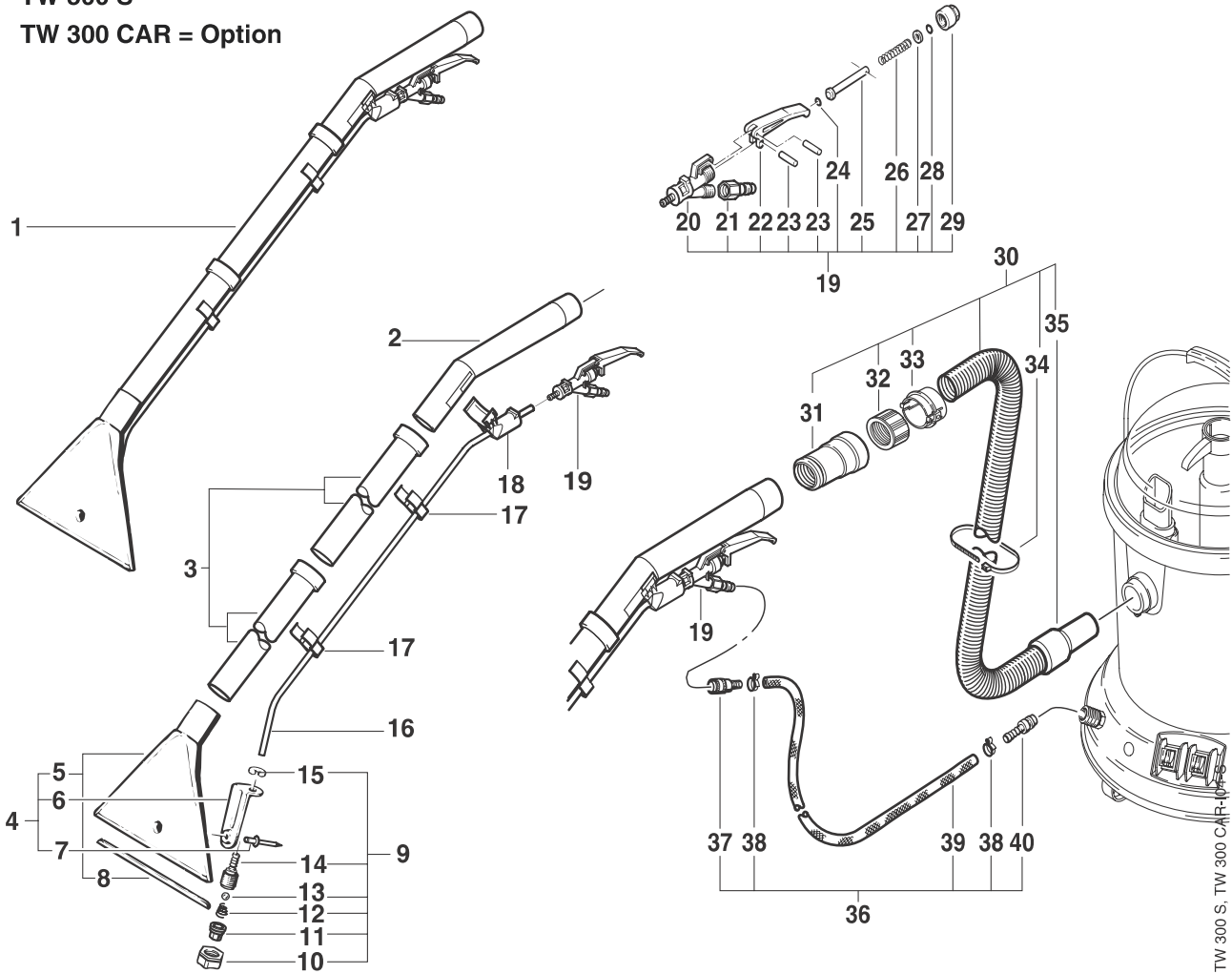

TW 300 S, TW 300 CAR

Pos.	No.	Description	Bezeichnung	Comment Bemerkung Bemærkning	Rec. Part	TW 300 S	TW 300 CAR
26	7370	Spring	Feder			1	
27	15498	Washer 5,3x1	Scheibe 5,3x1			1	
28	7368	O-ring Ø5x2	O-Ring Ø5x2			1	
29	7371	Cap Nut G3/8"x19,2	Überwurfmutter G3/8"x19,2			1	
30	34484	Suction Hose Ø32x3000	Saugschlauch Ø32x3000			1	
31	34487	Hose Sleeve Ø32	Muffe Ø32			1	
32	302000476	Bushing Ø32	Überwurfmuffe Ø32			2	
33	61154	Ring Ø32	Ring Ø32			2	
34	8819	Cable Strap 4,5x1x350	Kabelband 4,5x1x350			3	
35	46679	Hose Sleeve 35mm	Muffe 35mm			1	
36	7359	Spray Hose Ø6x3m	Sprühschlauch Ø6x3m			1	
37	7238	Coupling	Kupplung			1	
38	7239	Hose Clip Ø14,5	Schlauchschelle Ø14,5			2	
⇧	39	4973	Hose Ø6x3	Schlauch Ø6x3		1	
40	7302	Hose Liner Ø8	Schlauchtülle Ø8			1	

TW 300 CAR
TW 300 S = Option

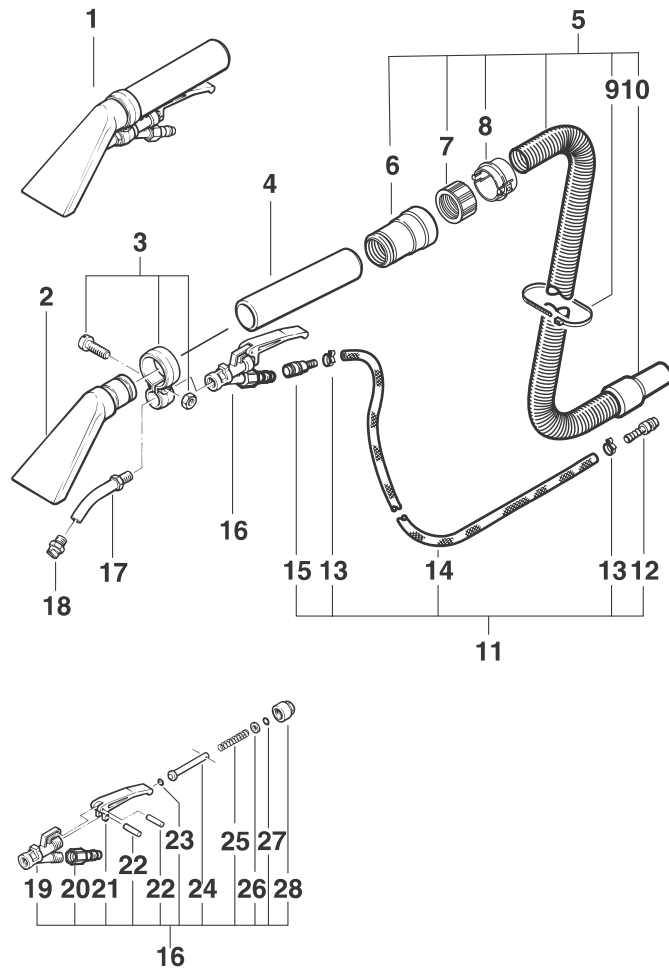

TW 300 S, TW 300 CAR-104-S

Pos.	No.	Description	Bezeichnung	Comment Bemerkung Bemærkning	Rec. Part	TW 300 S	TW 300 CAR
1	6696	Hand Adaptor 80mm	Handadapter 80mm				1
2	7377	Suction Nozzle 8cm	Saugdüse 8cm				1
3	7246	Pipe Clamp	Rohrschelle				1
4	7375	Pipe Ø33x180	Rohr Ø33x180				1
5	34484	Suction Hose Ø32x3000	Saugschlauch Ø32x3000				1
6	34487	Hose Sleeve Ø32	Muffe Ø32				1
7	302000476	Bushing Ø32	Überwurfmuffe Ø32				1
8	61154	Ring Ø32	Ring Ø32				1
9	8819	Cable Strap 4,5x1x350	Kabelband 4,5x1x350				3
10	46679	Hose Sleeve 35mm	Muffe 35mm				1
11	7359	Spray Hose Ø6x3m	Sprühschlauch Ø6x3m				1
12	7302	Hose Liner Ø8	Schlauchtülle Ø8				1
13	7239	Hose Clip Ø14,5	Schlauchschelle Ø14,5				2
⇨ 14	4973	Hose Ø6x3	Schlauch Ø6x3				1
15	7238	Coupling	Kupplung				1
16	7366	Lever	Hebelventil	consisting of 19 - 28			1
17	7256	Nozzle Tube	Düsenrohr				1
18	7376	HP Nozzle 1/8-27NPT	HD-Düse 1/8-27NPT				1
19	34483	Valve Body	Ventilkörper		C		1
20	7369	Coupler Nipple 1/4	Kupplungsrippel 1/4				1
21	7399	Lever	Ventilhebel				1
22	7401	Cylindrical Pin 1,5x14	Zylinderstift 1,5x14				2
23	3001633	O-ring Ø5,3x2,4	O-Ring Ø5,3x2,4				1
24	7400	Valve Pin	Ventilstift				1

303000007 - 2005-07-12

TW 300 CAR
 TW 300 S = Option

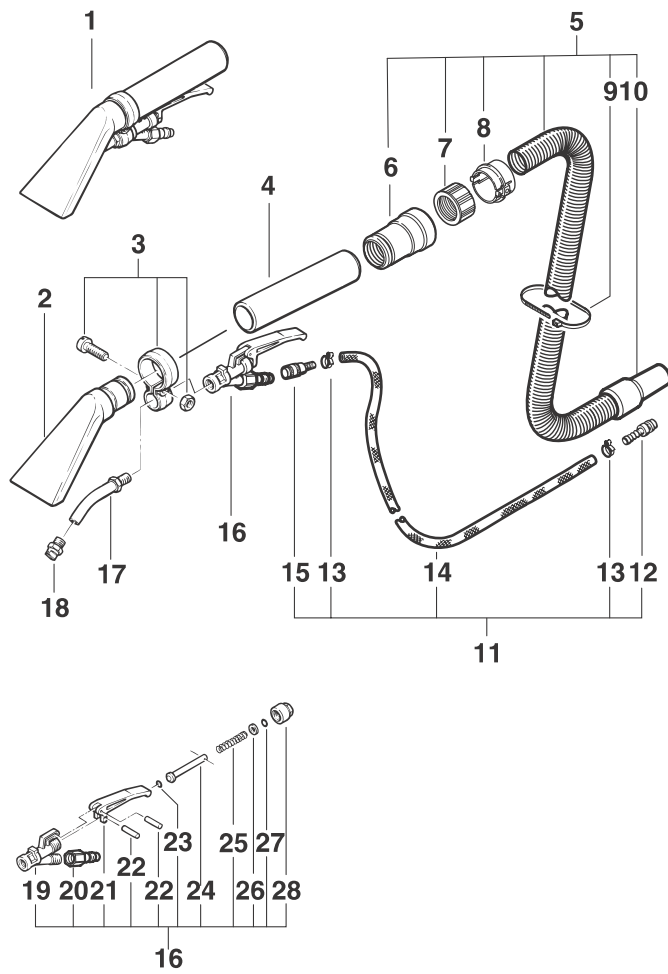

TW 300 S, TW 300 CAR-104-S

Pos.	No.	Description	Bezeichnung	Comment Bemerkung Remarque Bemærkning	Rec. Part		
					TW 300 S	TW 300 CAR	
25	7370	Spring	Feder			1	
26	15498	Washer 5,3x1	Scheibe 5,3x1			1	
27	7368	O-ring Ø5x2	O-Ring Ø5x2			1	
28	7371	Cap Nut G3/8"x19,2	Überwurfmutter G3/8"x19,2			1	

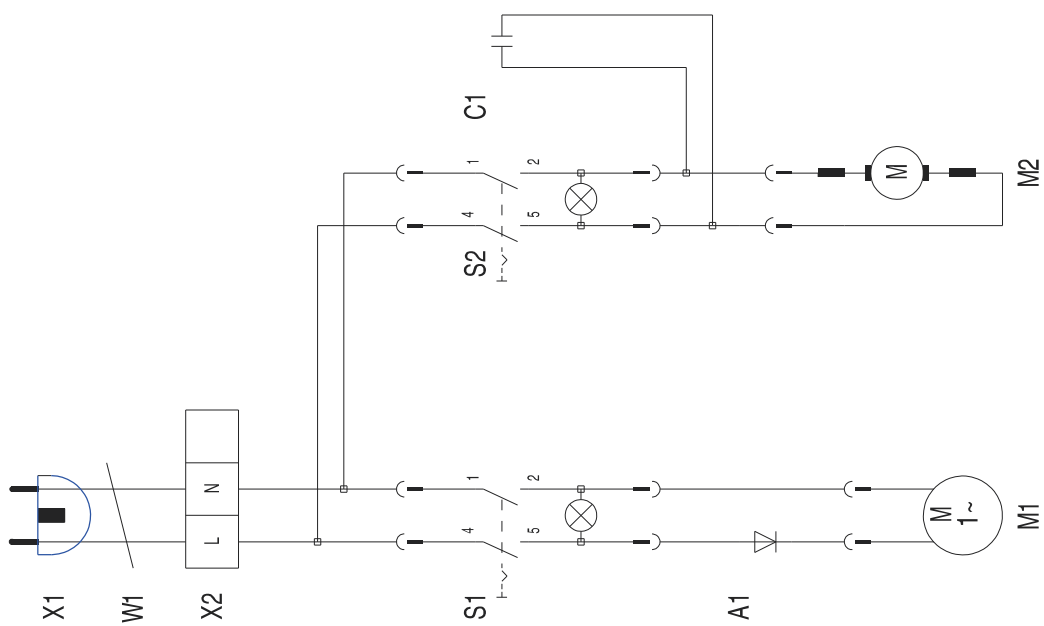

A1 C1 M1 M2 S1 S2 W1 X1 X2

Diode
Entstoerkondensator
Schwingkolbenpumpe
Saugmotor
Schalter fuer Schwingkolbenpumpe
Schalter fuer Saugmotor
Anschlusseitung
Anschlusstecker
Anschlussklemme

Diode
Decoupling capacitor
Pump
Vac motor
Pump switch
Vac motor switch
Power cord
Plug
Terminal

Nilfisk ALTO

Why Compromise

www.nilfisk-alto.com

HEADQUARTER

DENMARK

Nilfisk-Advance Group
Sognevej 25
2605 Brøndby
Denmark
Tel.: (+45) 43 23 81 00
Fax: (+45) 43 43 77 00
E-mail: mail@nilfisk-advance.dk

SALES COMPANIES

AUSTRALIA

Nilfisk-ALTO
48 Egerton St.
PO box 6046
Silverwater NSW 2128
Australia
Tel.: (+61) 2 8748 5966
Fax: (+61) 2 8748 5960

AUSTRIA

Nilfisk-Advance GmbH.
Nilfisk-ALTO
Metzgerstrasse 68
A-5101 Bergheim bei Salzburg
Tel.: (+43) 662 456 400-0
Fax: (+43) 662 456 400-34
E-mail: info@nilfisk-alto.at
www.nilfisk-alto.at

BRASIL

Wap do Brasil Ltda.
Rua das Palmeiras, 350
Capela Velha
83.705-500 – Araucária - PR
Brasil
Tel.: (+55) 41 2106 7400
Fax: (+55) 41 2106 7403
E-mail: export@wapdobrasil.com.br

CANADA

ALTO Canada
24 Constellation Road
Rexdale
Ontario M9W 1K1
Canada
Tel.: (+1) 416 675 5830
Fax: (+1) 416 675 6989

CZECH REPUBLIC

ALTO Česká republika s.r.o.
Zateckých 9
14000 Praha 4
Czech Republic
Tel.: (+420) 24 14 08 419
Fax: (+420) 24 14 08 439
E-mail: wap_p@mbox.vol.cz

DENMARK

Nilfisk-ALTO
Division of Nilfisk-Advance A/S
Industrivej 1
9560 Hadsund
Denmark
Tel.: (+45) 72 18 21 00
Fax: (+45) 72 18 21 11
E-mail: salg@nilfisk-alto.dk
E-mail: service@nilfisk-alto.dk
www.nilfisk-alto.dk

Nilfisk-ALTO Food Division
Division of Nilfisk-Advance A/S
Blytækkervej 2,
9000 Aalborg
Denmark
Tel.: (+45) 72 18 21 00
Fax: (+45) 72 18 20 99
E-mail: scanio.technology@nilfisk-alto.dk
www.nilfisk-alto.com

FRANCE

Nilfisk-ALTO
ALTO France SA
Aéroparc 1
19 rue Icare
67960 Entzheim
France
Tel.: (+33) 3 88 28 84 00
Fax: (+33) 3 88 30 05 00
E-mail: info@nilfisk-alto-fr
www.nilfisk-alto.com

GERMANY

Nilfisk-Advance AG
Nilfisk-ALTO Business Unit
Guido-Oberdorfer-Str. 10
89287 Bellenberg
Germany
Tel.: (+49) (0) 180 5 37 37 37
Fax: (+49) (0) 180 5 37 37 38
E-mail: info@nilfisk-alto.de
www.nilfisk-alto.de

HOLLAND

Nilfisk-ALTO
Division of Nilfisk-Advance BV
Camerastraat 9
NL-1322 BB Almere
Tel.: (+31) 36 5460 760
Fax: (+31) 36 5460 761
E-mail: info@nilfisk-alto.nl
www.nilfisk-alto.nl

HONG KONG

Nilfisk-Advance Ltd.
2001 HK Worsted Mills Ind'l Bldg.,
31-39 Wo Tong Tsui St.
Kwai Chung, Hong Kong
Tel.: (+852) 2427 5951
Fax: (+852) 2487 5828

HUNGARY

Kvantor-Itb Kft
II. Rákóczi Ferenc út 10
2310 Szigetszentmiklos-Lakihegy
Hungary
Tel.: (+36) 24 47 55 50
Fax: (+36) 24 47 55 51
E-mail: nilfisk@kvantor-itb.hu

JAPAN

Nilfisk-Advance, Inc.
1-6-6 Kita-shinyokohama, Kouhoku-ku,
Yokohama, 223-0059
Japan
Tel.: (+81) 45 548 2571
Fax: (+81) 45 548 2541

MALAYSIA

Nilfisk-Advance Sdn Bhd
No. 1011, Block A4
Leisure Commerce Square
No. 9, Jalan PJS 8/9
46150 Petaling Jaya
Selangor, Malaysia
Tel.: (+60) 3 603 7876 4222
Fax: (+60) 3 603 7876 3878

PEOPLE'S REPUBLIC OF CHINA

Nilfisk-Advance (Shenzhen) Ltd
Blok 3, Unit 130, 1001 Honghua Road
Int. Commercial & Trade Center
Fuitian Free Trade Zone
518038 Shenzhen
P.R. China
Tel.: (+86) 755 8359 7937
Fax: (+86) 755 8359 1063

POLAND

Nilfisk-ALTO
Division of Nilfisk-Advance A/S
05-800 Pruszków
ul. 3-go MAJA 8
Poland
Tel.: (+48) 22 738 37 50
Fax: (+48) 22 738 37 51
info@nilfisk-alto.pl
www.nilfisk-alto.pl

NORWAY

ALTO Norge AS
Bjørnerudveien 24

1266 Oslo
Norway
Tel.: (+47) 22 75 17 70
Fax: (+47) 22 75 17 71
E-mail: info@nilfisk-alto.no
www.nilfisk-alto.no

PORTUGAL

Nilfisk-ALTO
Division of Nilfisk-Advance Lda.
Sintra Business Park
Zona Industrial Da Abrunheira
Edifício 1, 1º A
P-2710-089 Sintra
Tel.: (+35) 808 200 537
Fax: (+35) 121 911 2679
E-mail: mkt@nilfisk-advance.es
www.nilfisk-alto.com

SINGAPORE

Nilfisk-Advance Pte. Ltd.
Nilfisk-ALTO Division
40 Loyang Drive
Singapore 508961
sales@nilfisk-advance.com.sg
Tel.: (+65) 6 759 9100
Fax: (+65) 6 759 9133

SPAIN

Nilfisk-ALTO
Division of Nilfisk-Advance S.A.
Torre DAra
Paseo del Rengle, 5 Pl. 10
E-08302 Mataró
Tel.: (+34) 902 200 201
Fax: (+34) 93 757 8020
E-mail: mkt@nilfisk-advance.es
www.nilfisk-alto.com

SWEDEN

ALTO Sverige AB
Member of Nilfisk-Advance Group
Aminogatan 18, Box 4029
S-431 04 Mölndal
Sweden
Tel.: (+46) 31 706 73 00
Fax: (+46) 31 706 73 40
E-mail: info@nilfisk-alto.se
www.nilfisk-alto.se

TAIWAN

Nilfisk-Advance Ltd.
Taiwan Branch (H.K.)
1F, No. 193, Sec.2
Xing Long Rd., Taipei
Taiwan, R.O.C.
Tel.: (+886) 2 2239 8812
Fax: (+886) 2 2239 8832

THAILAND

Nilfisk-Advance Co. Ltd.
89 Soi Chochechai-Ruammitr
Viphavadee-Rangsit Road
Ladyao, Jatuchak, Bangkok 10900
Thailand
Tel.: (+66) 2 275 5630
Fax: (+66) 2 691 4079

UNITED KINGDOM

Nilfisk-ALTO
Division of Nilfisk-Advance Ltd.
Bowerbank Way
Gilwilly Industrial Estate
Penrith Cumbria CA11 9BQ
Great Britain
Tel.: (+44) (0) 1768 868995
Fax: (+44) (0) 1768 864713
E-mail: sales@nilfisk-alto.co.uk
www.nilfisk-alto.co.uk

USA

ALTO Cleaning Systems Inc.
Part of the Nilfisk-Advance Group
12249 Nations Ford Road
Pineville, NC 28134
USA
Tel.: (+1) 704 971 1240
Fax: (+1) 704 971 1241
E-mail: info@nilfisk-advance.us
www.nilfisk-alto.com