

**Reservedele • Spare parts  
Ersatzteile • Pièces détachées**

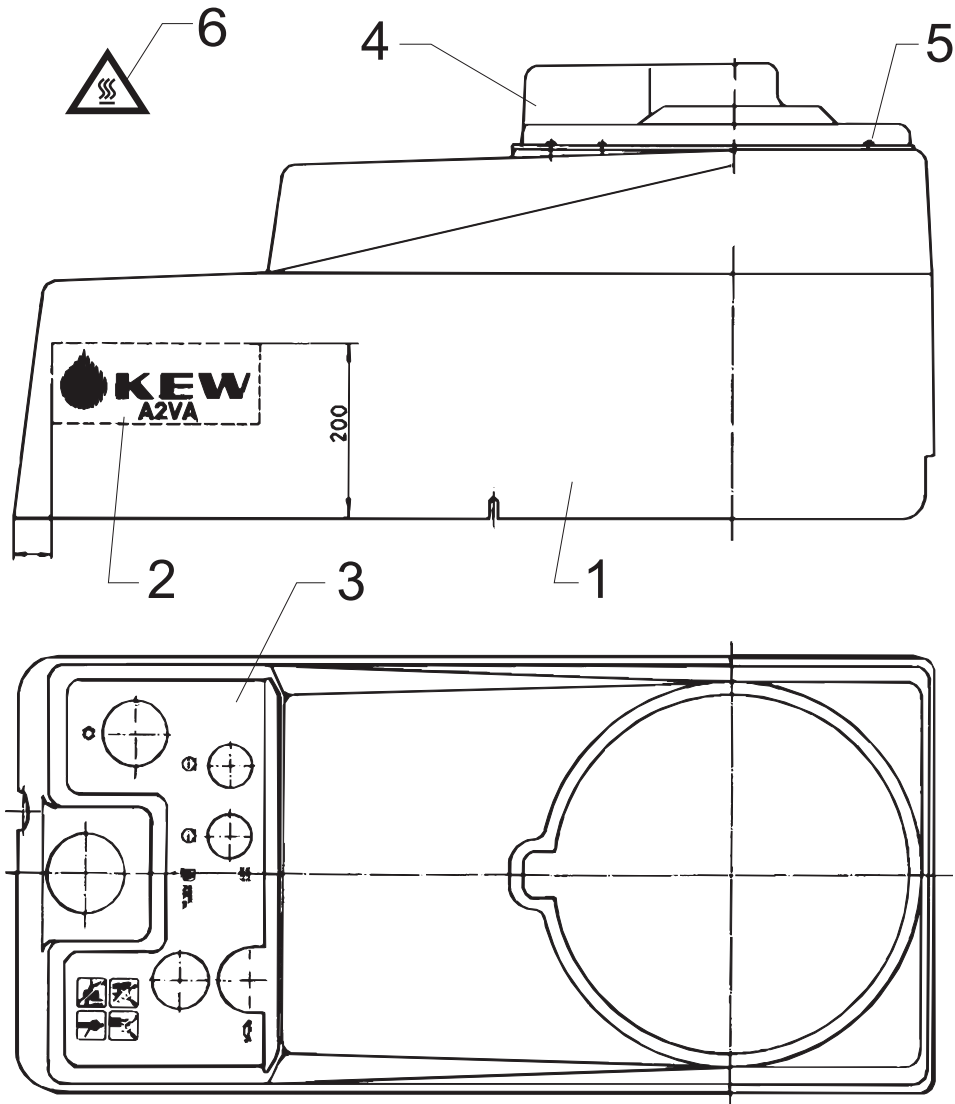



Pos. Ref.	Nr. No.	Betegnelse Bezeichnung	Designation Désignation	16A2V/VA	23A2V/VA	26A2V/VA	38A2V/VA
-	-	Kabinet, kompl. Cabinet, compl. Haube, kompl. Capot, compl.		x	x	x	x
1	6201060	Kabinet Cabinet Haube Capot	A2V				
1	6201100	Kabinet Cabinet Haube Capot	(16A2V, CDN) A2VA				
2	-	Logo Logo Logo Logo					
-	6201077	16A2V	USA, SGP J	2	2	2	2
-	6201076	23A2V					
-	6201119	26A2V					
-	6201075	38A2V					
-	6201074	16A2VA	USA, SGP J	2	2	2	2
-	6201073	23A2VA					
-	6201118	26A2VA					
-	6201072	38A2VA					
3	6201117	Instrument panel Control panel Armaturenbrett Tableau de commande	A2V	1	1	1	
-	6201101	Instrument panel Control panel Armaturenbrett Tableau de commande	A2VA	1	1	1	1
-	6220733	Instrument panel Control panel Armaturenbrett Tableau de commande	CDN	1	1	1	
4	6200287	Kedel top Boiler, top section Kessel, oberer Teil Chaudière, partie supérieure	D				1
5	1801406	Skrue Screw Schraube Vis	D				6
6	4210066	Advarselslabel "varmeoverførsel" Warning label "heat transfer" Warnaufkleber Wärmeübertragung Avertis. "transmission chaaleur"		1	1	1	1

Pos. Ref.	Nr. No.	Betegnelse Bezeichnung	Designation Désignation	16A2V/VA	23A2V/VA	26A2V/VA	38A2V/VA
-	-	Instruktionsbøger Instruction manuals Betriebsanleitungen Livrets d'instructions		1	1	1	1
	6209078	DK					
	6209079	GB					
	6209080	D					
	6209081	F					
	6209082	NL					
	6209083	S					
	6209086	USA, CDN					

Stel / Chassis / Rahmen / Châssis

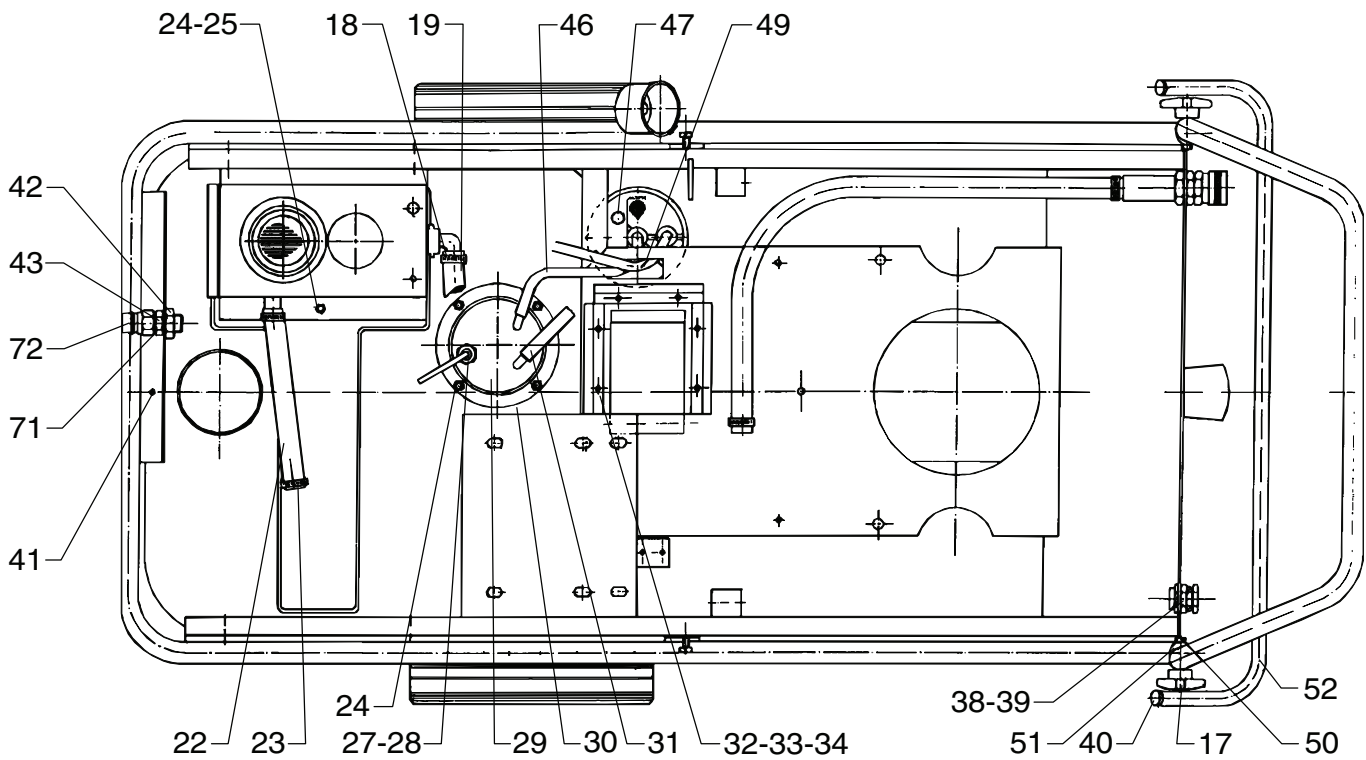
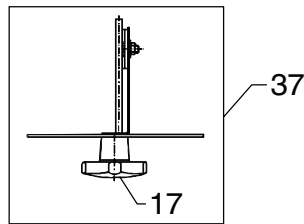
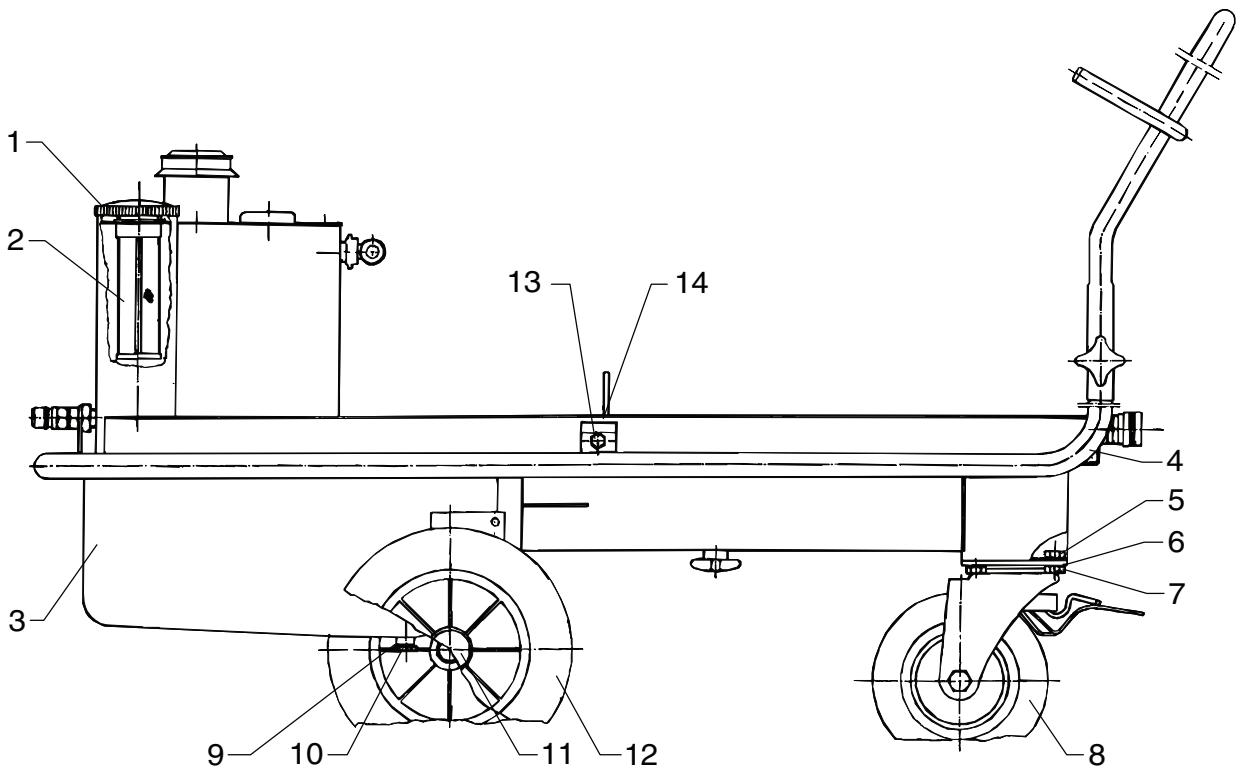

Pos. Ref.	Nr. No.	Betegnelse Bezeichnung	Designation Désignation	16A2V/VA	23A2V/VA	26A2V/VA	38A2V/VA
-	-	Stel, monteret Chassis, mount. Rahmen, montiert Châssis, monté		x	x	x	x
1	2011104	Låg f. brændstof Cover f. fuel tank Deckel f. Brennstofftank Couvercle du réservoir fuel		1	1	1	1
2	1604222	Påfyldningssi Fuel filling (filter) Brennstoffauffüllung (Filter) Filtre		1	1	1	1
3	6200203	Brændstofftank Fuel tank Brennstofftank Réservoir à fuel		1	1	1	1
4	6200204	Stel Chassis Rahmen Châssis		1	1	1	1
-	6201200	Stel Chassis Rahmen Châssis	CDN, 1x115V	1	1	1	1
5	1802305	Skrue Screw Schraube Vis		4	4	4	4
6	1801968	Skive Washer Scheibe Rondelle		4	4	4	4
7	1800465	Møtrik Nut Mutter Ecrou		4	4	4	4
8	2005619	Drejehjul Steerable wheel Lenkrad Roue pivotante		1	1	1	1
9	3001468	Fiberskive Washer Scheibe Rondelle		1	1	1	1
10	6200529	Aftapningsskrue Drain screw Ablassschraube Vis de vidange fuel		1	1	1	1
11	102004266	Navkapsel, kompl. Hub cap, compl. Nabenkappe, kompl. Enjoliveur, compl.	01.03.02 =>	2	2	2	2
11	2004265	Navkapsel Hub cap Nabenkappe Enjoliveur	=> 28.02.02	2	2	2	2
12	301000041	Hjul Wheel Rad Roue	01.03.02 =>	2	2	2	2
12	-	Hjul Wheel Rad Roue	=> 28.02.02	2	2	2	2
13	6200145	Skrue Screw Schraube Vis		2	2	2	2
14	1803832	Seegerring Seeger circlip ring Seeger-Ring Anneau Seger		2	2	2	2
17	4000279	Stjernegreb Star handle Sterngriff Poignée en étoile		3	3	3	3
18	5206065	Slange Hose Schlauch Tuyau	(L=230)	1	1	1	1

Pos. Ref.	Nr. No.	Betegnelse Bezeichnung	Designation Désignation	16A2V/VA	23A2V/VA	26A2V/VA	38A2V/VA
19	1801034	Spændebånd Hose clip Schelle Collier de serrage	(J, AUS 3 pcs.)	2	2	2	2
22	5206230	Slange Hose Schlauch Tuyau	(L=190)	1	1	1	1
23	1802107	Spændebånd Hose clip Schelle Collier de serrage		2	2	2	2
24	1802743	Møtrik Nut Mutter Ecrou		5	5	5	5
25	1804152	Skive Washer Scheibe Rondelle		1	1	1	1
27	1801026	Møtrik Nut Mutter Ecrou		1	1	1	1
28	3000429	Fiberskive Fibre washer Fiberscheibe Rondelle		1	1	1	1
29	6200202	Dæksel Cover Deckel Couvercle		1	1	1	1
30	6240091	Pakning Gasket Dichtung Joint		1	1	1	1
31	5226220	Olieslange Hose (fuel) Schlauch (Brennstoff) Durite à fuel	(L=220)	1	1	1	1
32	6200088	Holder Holder Halter Support		3	3	3	3
33	1803618	Popnitte Rivet Niet Rivet		6	6	6	6
34	6200089	Pakning Gasket Dichtung Joint		1	1	1	1
37	6202222	Spjældplade, kompl. Plate f. throttle, compl. Platte f. Luftschieber, kompl. Plaque du régulateur, compl.		1	1	1	1
38	3800786	Kontramøtrik Lock nut Gegenmutter Contre écrou		1	1	1	1
-	3808169	Kontramøtrik Lock nut Gegenmutter Contre écrou	CDN, 1x115V	1			
39	3800760	Trækafastning Cable lead- in Zugentlastung Passe fil		1	1	1	1
-	3802212	Trækafastning Cable lead- in Zugentlastung Isolateur de traversée	CDN, 1x115V	1			
40	4600490	Dupsko Ferrule Zwinge Embout		2	2	2	2
41	1803592	Skrue Screw Schraube Vis		7	7	7	7

Stel / Chassis / Rahmen / Châssis

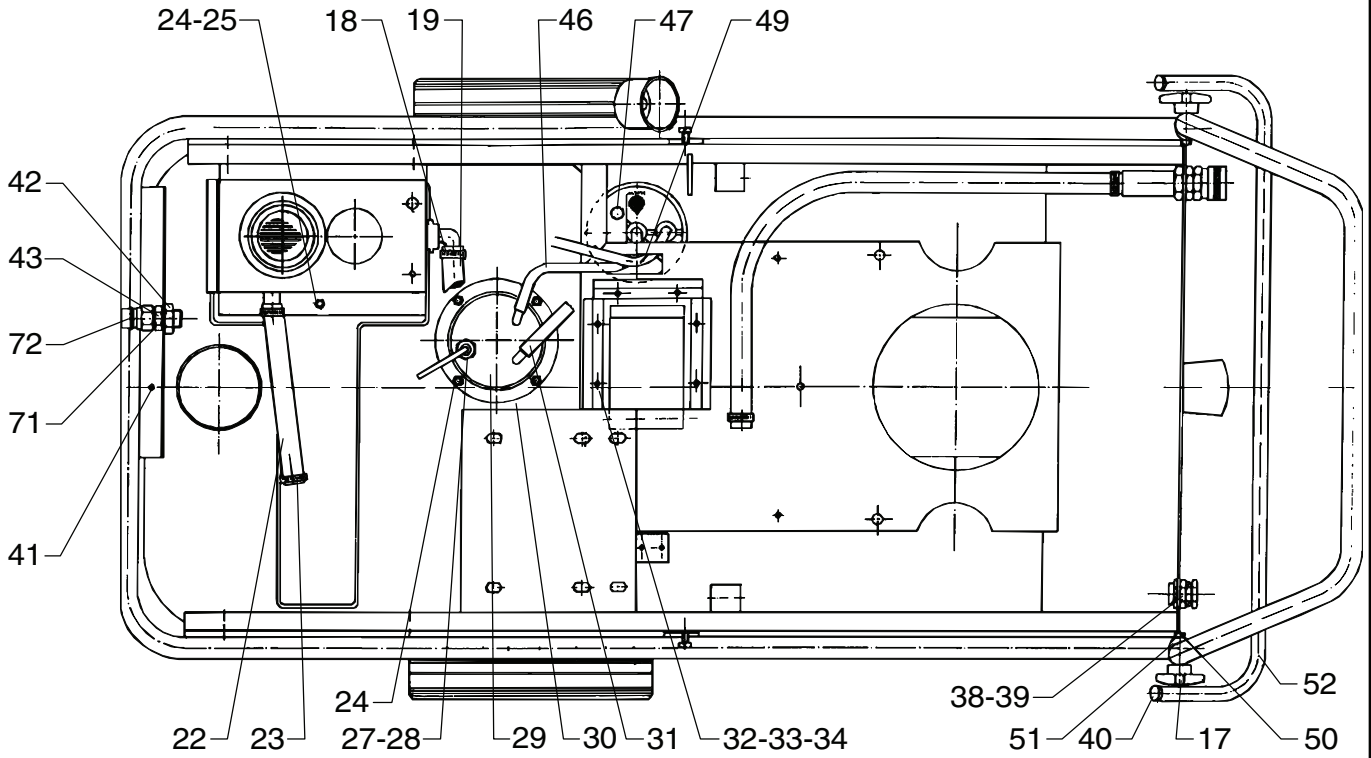

60

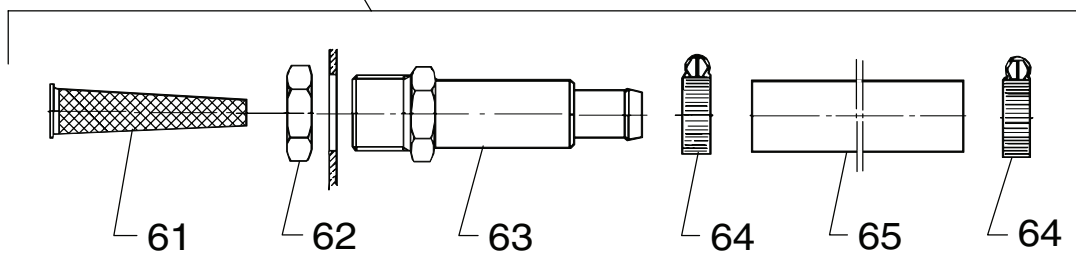

Lynkbling / Quick coupling / Schnellkupplung / Coupleur rapide

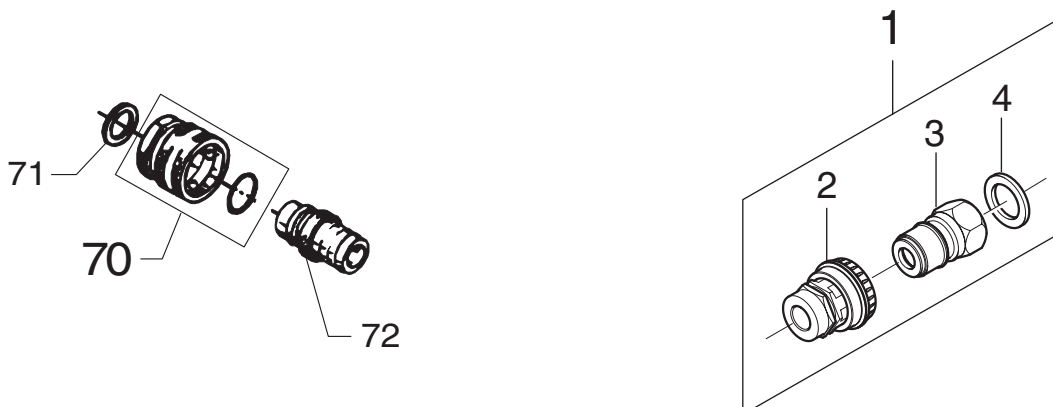

Pos. Ref.	Nr. No.	Betegelse Bezeichnung	Designation Désignation	16A2/V/A	23A2/V/A	26A2/V/A	38A2/V/A
42	1803220	Kontramøtrik Lock nut Gegenmutter Contre écrou		1	1	1	1
43	6200484	Forskruning Threaded connection Verschraubung Raccord fileté		1	1	1	1
46	5226220	Olieslange Hose (fuel) Schlauch (Brennstoff) Durite à fuel	(L=220)	1	1	1	1
-	5226220	Olieslange Hose (fuel), <b>CDN</b> Schlauch (Brennstoff) Durite à fuel	(L=340)	1			
47	1810167	Skrue Screw Schraube Vis		2	2	2	2
49	5226220	Olieslange Hose (fuel) Schlauch (Brennstoff) Tube (fuel)	(L=265)	1	1	1	1
-	5226220	Olieslange Hose (fuel), <b>CDN</b> Schlauch (Brennstoff) Tube (fuel)	(L=340)	1			
50	6100123	Stelskrue Screw Schraube Vis		2	2	2	2
51	4600559	Dupsko Ferrule Zwinge Embout		2	2	2	2
52	6200249	Bagbøjle Handle, back Bügel, hinten Poignée, arrière		1	1	1	1
<b>60</b>	-	<b>Vandtilslutning, kompl.</b> <b>Water inlet, compl.</b> <b>Wasseranschluss, kompl.</b> <b>Admission eau, compl.</b>		<b>x</b>	<b>x</b>	<b>x</b>	<b>x</b>
61	6100941	Filter Filter Filter Filtre		1	1	1	1
62	1800341	Kontramøtrik Lock nut Gegenmutter Contre-écrou		1	1	1	1
63	6100937	Filterhus Filter housing Gehäuse f. Filter Carter filtre		1	1	1	1
64	1802107	Spændebånd Hose clip Schelle Collier de serrage		2	2	2	2
65	5206487	Slange Hose Schlauch Flexible	(L=630)	1	1	1	1
<b>70</b>	<b>1602945</b>	<b>Lynkobling, kompl. (lavtryk)</b> <b>Quick coupling, compl. (l.p.)</b> <b>Schnellkupplung, kompl. (N.D.)</b> <b>Coupleur rapide, compl. (b.p.)</b>		<b>1</b>	<b>1</b>	<b>1</b>	<b>1</b>
71	1801075	Tætningsskive Sealing washer Dichtungsscheibe Rondelle d'étanchéité		2	2	2	2
72	-	Lynkoblingsnippel (lavtryk) Nipple f. quick coupling (l.p.) Nippel f. Schnellkupplung (N.D.) Entrée du coupleur rapide (b.p.)					
-	1600659	3/4"					
-	1602473	5/8"					
			<b>USA</b>				

Pos. Ref.	Nr. No.	Betegelse Bezeichnung	Designation Désignation	16A2/V/A	23A2/V/A	26A2/V/A	38A2/V/A
1	101119499	<b>Koblingsæt f. højtryksslange (h.t.)</b> <b>Coupling kit f. high pres. hose (h.p.)</b> <b>Kupplungsatz f. Hochdruckschlauch (H.D.)</b> <b>Kit de coupleur p. tuyau (h.p.)</b>		x	x	x	x
2	106402075	Lynkobling, kompl. (damp) Quick coupling, compl. (steam) Schnellkupplung, kompl. (Dampf) Coupleur rapide, compl. (vapeur)		1	1	1	1
3	1600493	Lynkoblingsnippel (højtryk) Nipple f. quick coupling (h.p.) Nippel f. Schnellkupplung (H.D.) Entrée du coupleur rapide (h.d.)					
-	1603101	Lynkoblingsnippel, RF (højtryk) Nipple f. quick coupling, SS H.P. Nippel f. Schnellkupplung, RF H.D. Entrée du coupleur rapide, INOX H.P.					
4	1801075	Tætningsskive Sealing washer Dichtungsscheibe Rondelle d'étanchéité		1	1	1	1

598 75 99 - Jun. 2004

Oliefilter / Fuel filter / Brennstofffilter / Filtre à fuel

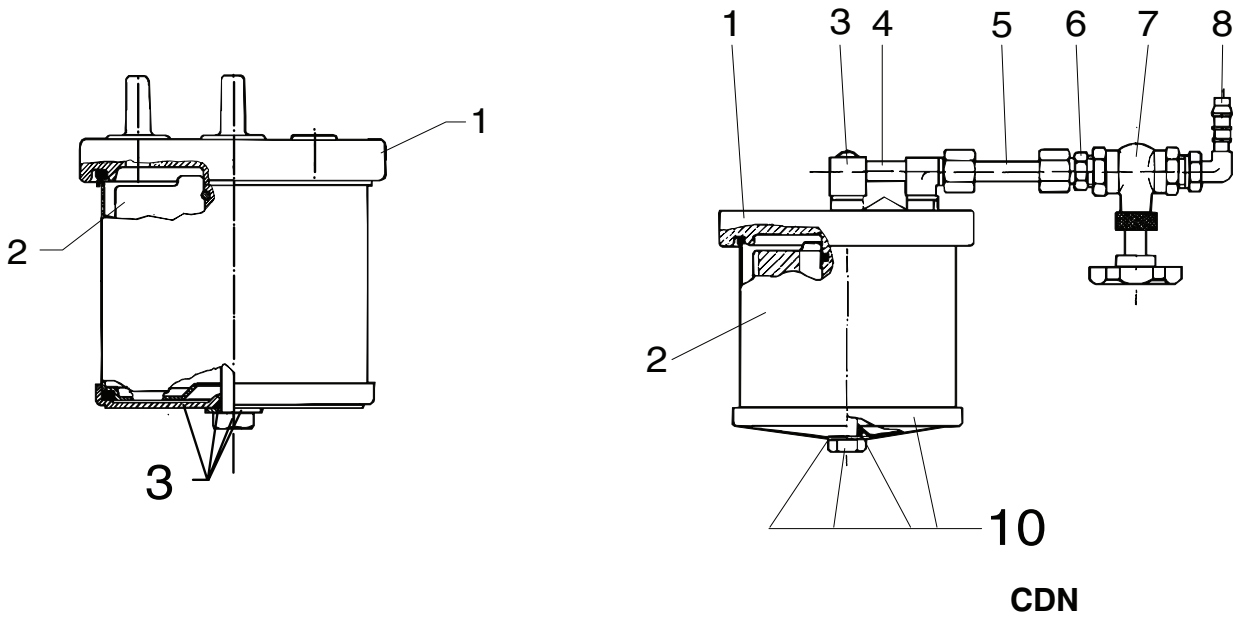

Niveauekontakt / Level switch / Niveauschalter / Contrôleur de niveau

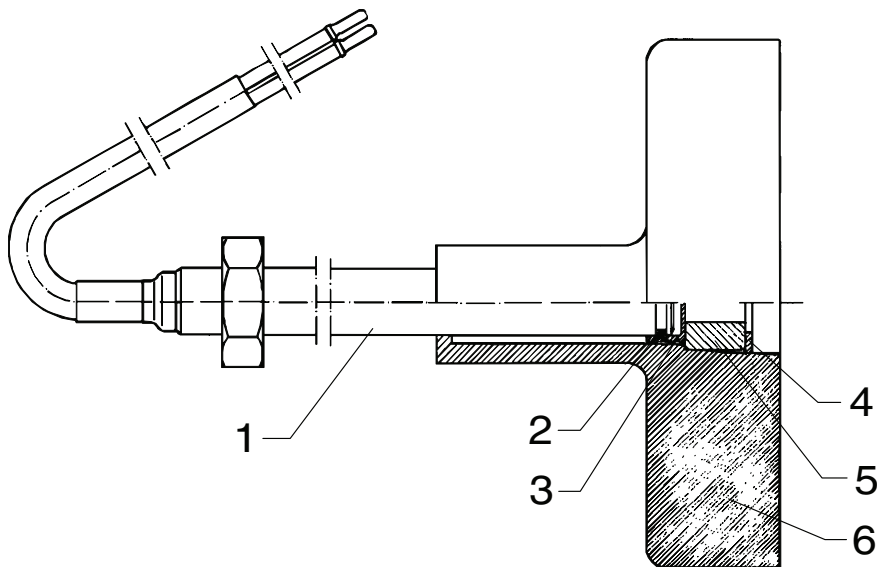

Filterhus / Filter housing / Gehäuse f. Filter / Carter filtre

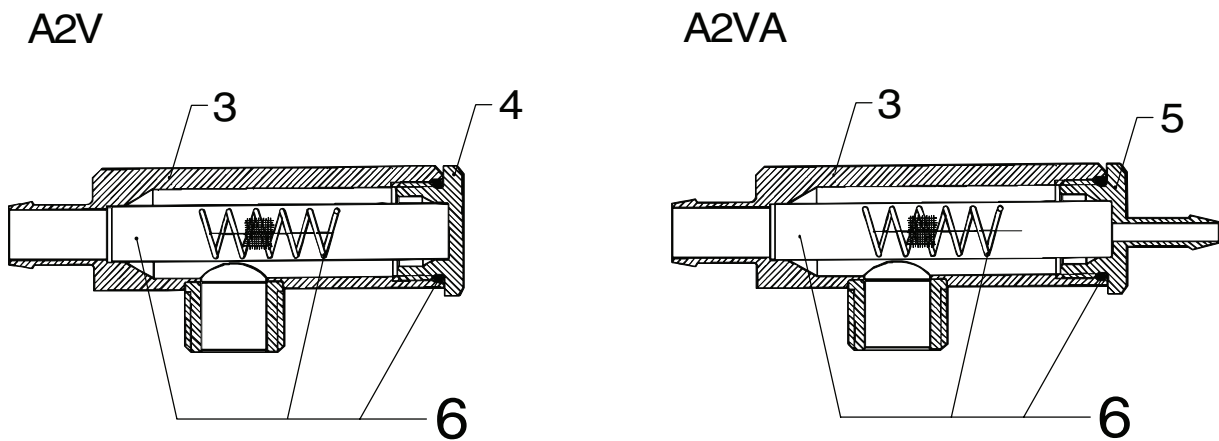



Pos. Ref.	Nr. No.	Betegnels Bezeichnung	Designation Désignation	16A2V/VA	23A2V/VA	26A2V/VA	38A2V/VA
-	6200466	<b>Oliefilter, komplet Fuel filter, complete Brennstofffilter, komplett Filtre à fuel, compl.</b>		x	x	x	x
1	6200445	Filterdæksel Filter cap Deckel für Filter Couvercle du filtre		1	1	1	1
2	1604248	Oliefilter Fuel filter Brennstofffilter Filtre à fuel		1	1	1	1
<b>3</b>	<b>1119301</b>	<b>Rep.sæt, filter bund Kit, bottom sect. f. filter housing Satz, Unterer Teil f. Filtergehäuse Kit, part. infér. du carter filtre</b>		1	1	1	1
-	6200471	<b>Oliefilter, komplet Fuel filter, compl. Brennstofffilter, komplett Filtre à fuel, compl.</b>	<b>CDN, 16A2V</b>	x			
1	6220411	Filterdæksel Filter cap Deckel für Filter Couvercle du filtre		1			
2	1604248	Oliefilter Fuel filter Brennstofffilter Filtre à fuel		1			
3	1602317	Fitting Fitting Halterung Garniture		2			
4	6222480	Olierør L=112mm Tube Rohr Tube		1			
5	6222481	Olierør L=44mm Tube Rohr Tube		1			
6	1602259	Fitting Fitting Halterung Garniture		2			
7	1601186	Nåleventil Needle valve Nadelventil Soupape à pointeau		2			
8	1604008	Slangestuds Hose socket Schlauchstutzen Raccord		2			
<b>10</b>	<b>1119301</b>	<b>Rep.sæt, filter bund Kit, bottom sect. f. filter housing Satz, Unterer Teil f. Filtergehäuse Kit, part. infér. du carter filtre</b>		1			

Pos. Ref.	Nr. No.	Betegnels Bezeichnung	Designation Désignation	16A2V/VA	23A2V/VA	26A2V/VA	38A2V/VA
-	6200208	<b>Niveauekontakt, kompl. Level switch, compl. Niveauschalter, kompl. Contrôleur de niveau, compl.</b>		x	x	x	x
1	6200083	Rør Tube Rohr Corps		1	1	1	1
2	3000296	O-ring O-ring O-Ring Joint torique		1	1	1	1
3	6200067	Hætte Cap Kappe Capuchon		1	1	1	1
4	1803634	Låsering Circlip Sicherungsring Circlip		1	1	1	1
5	1803485	Magnet Magnet Magnet Aimant		1	1	1	1
6	6200060	Flyder Float Schwimmer Floteur		1	1	1	1
-	6105388	<b>Filterhus, kompl. Filter housing, compl. Gehäuse f. Filter, kompl. Carter filtre, compl.</b>	<b>A2V</b>	x	x	x	x
-	6200937	<b>Filterhus, kompl. Filter housing, compl. Gehäuse f. Filter, kompl. Carter filtre, compl.</b>	<b>A2VA</b>	x	x	x	x
3	6105625	Filterhus Filter housing Gehäuse f. Filter Carter filtre		1	1	1	1
4	6105545	Prop Plug Pfropfen Bouchon	<b>A2V</b>	1	1	1	1
5	6201901	Slangestuds Hose socket Schlauchstutzen Raccord p. flexible	<b>A2VA</b>	1	1	1	1
<b>6</b>	<b>1119316</b>	<b>Rep. sæt, filterhus Rep. kit, filter housing Rep. sæt, Gehäuse f. Filter Kit de rép., carter filtre</b>		1	1	1	1

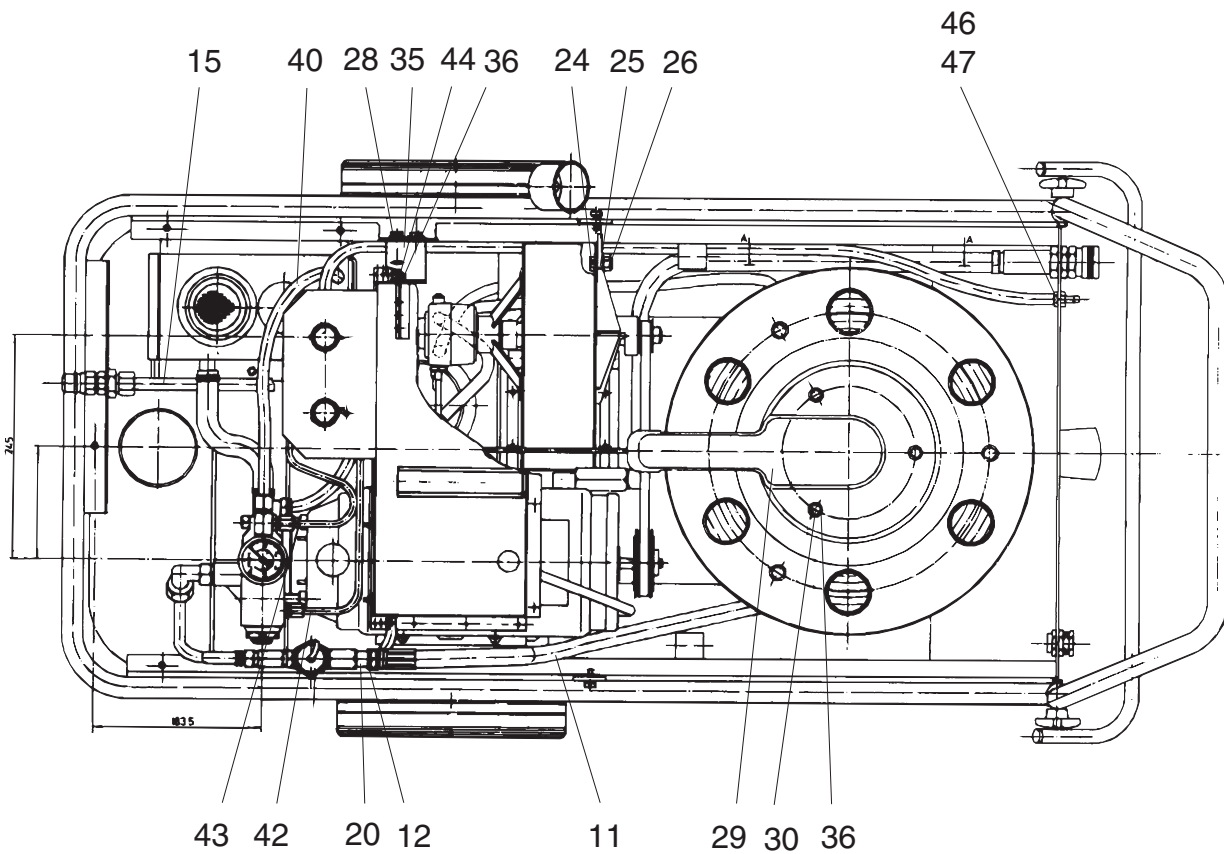
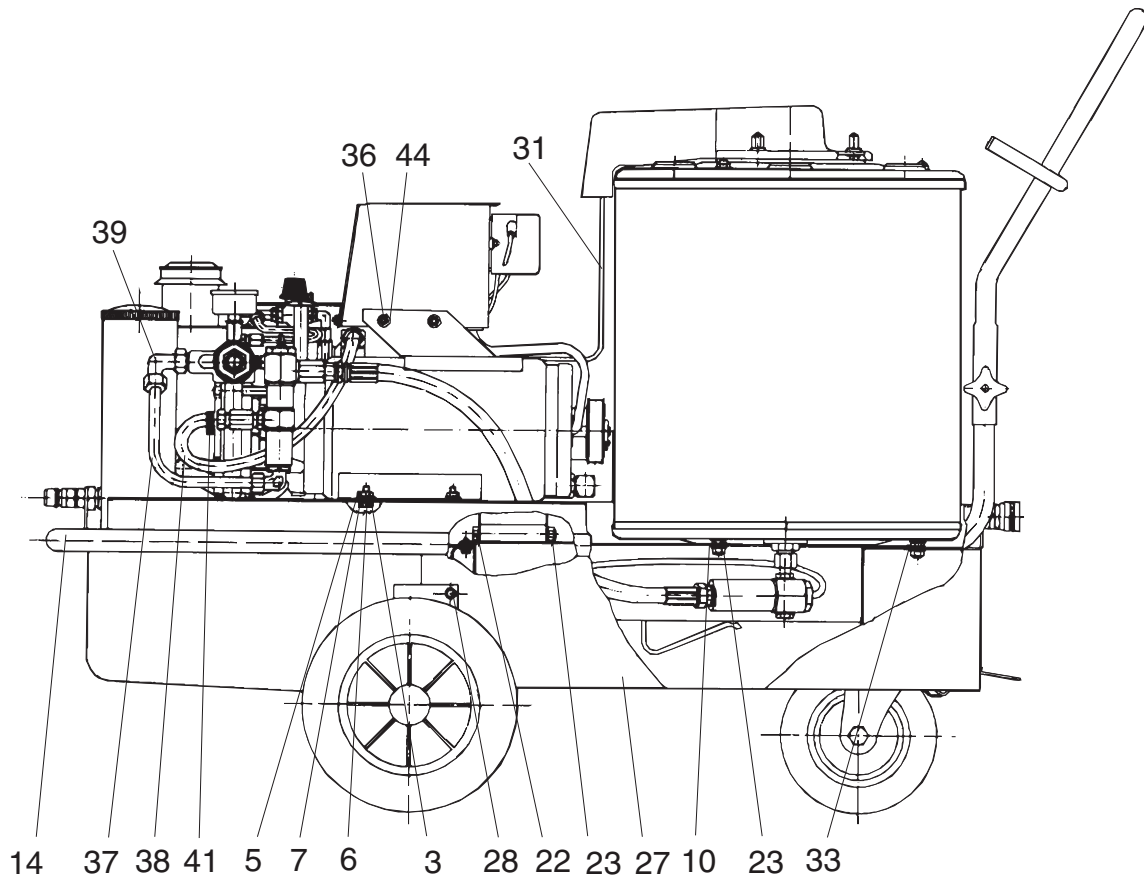

Pos. Ref.	Nr. No.	Betegnels Bezeichnung	Designation Désignation	16A2V/VA	23A2V/VA	26A2V/VA	38A2V/VA
-	-	Maskine, monteret Machine, mounted Maschine, montiert Appareil, monté		x	x	x	x
3	1801174	Skrue Screw Schraube Vis		4	4	4	4
5	1803725	Møtrik Nut Mutter Ecrou		4	4	4	4
6	1807445	Skive Washer Scheibe Rondelle		4	4	4	4
7	1800796	Skive Washer Scheibe Rondelle		4	4	4	4
10	1800796	Skive Washer Scheibe Rondelle		3	3	3	3
11	6200511	Intern højtryksslange High pressure hose Hochdruckschlauch Flexible haute pression	A2V	1	1	1	1
-	6200513	Intern højtryksslange High pressure hose Hochdruckschlauch Flexible haute pression	A2VA	1	1	1	1
12	1803493	Tætningskive Sealing washer Dichtungsscheibe Rondelle d'étanchéité		1	1	1	1
15	6200502	Trykrør, afgang Pressure pipe, outlet Druckrohr, Auslass Tuyau en départ		1	1	1	1
18	6105375	Oliefyldningsprop Oil filling plug Öleinfüllstutzen Tubulure de remplissage d'huile		1	1	1	1
20	1602267	Muffe Sleeve Muffe Manchon	A2VA	1	1	1	1
22	1803626	Bolt Bolt Bolzen Boulon		1	1	1	1
23	1800515	Møtrik Nut Mutter Ecrou		4	4	4	4
24	1800432	Skrue Screw Schraube Vis		1	1	1	1
25	6223089	Skive Washer Scheibe Rondelle		1	1	1	1
26	1800457	Låsemøtrik Lock nut Gegenmutter Ecrou de blocage		1	1	1	1
27	6200062	Dækplade Cover plate Abschlussdeckel Couverture		4	4	4	4
28	1803592	Skrue Screw Schraube Vis		6	6	6	6
29	6200280	Kedeltop Boiler top section Kessel, oberer Teil Chaudière, partie supérieure		1	1	1	1

Pos. Ref.	Nr. No.	Betegnels Bezeichnung	Designation Désignation	16A2V/VA	23A2V/VA	26A2V/VA	38A2V/VA
29	6200228	⇒ 01.07.93	N	1	1	1	1
29	6220268		CDN	1			
30	6200310	Top møtrik Nut Mutter Ecrou		3	3	3	3
-	1800705	Top møtrik Nut Mutter Ecrou	D	3	3	3	3
31	6200504	Dyserør, kompl. Fuel line, compl. Rohr f. Düse, kompl. Tube p. buse, compl.		1	1	1	1
33	6200093	Skive Washer Scheibe Rondelle		3	3	3	3
35	6201742	Stiver Support Stütze Support		1	1	1	1
-	6201754	1x115V	CDN	1			
-	6201775	1x220V	CDN	1			
36	1800440	Skive Washer Scheibe Rondelle		11	11	11	11
37	6200516	Trykrør Pressure pipe, outlet Druckrohr Tubulure de sortie	A2VA   09.04.89 ⇒ ⇒ 09.04.89	1	1	1	1
38	5206054	Meldeslange blå Alarm hose blue Alarmschlauch blau Flexible indicateur bleu	A2VA (L=440)	1	1	1	1
39	1604487	Vinkel Elbow Winkel Raccord coudé	A2VA ⇒ 09.04.89	1	1	1	1
40	5206636	Slange Hose Schlauch Flexible	A2VA (L=390)	1	1	1	1
41	1801034	Spændebånd Hose clip Schlauchschelle Collier de serrage		2	2	2	2
42	6200514	Afgangsrør Outlet tube Auslassrohr Tube de sortie		1	1	1	1
43	6240500	Rør f. temp. regl. Tube f. temp. regl. Rohr f. Temperaturreg. Tube p. rég. de temp.		1	1	1	1
44	1800457	Låsemøtrik Lock nut Gegenmutter Ecrou de blocage		3	3	3	3
46	1801026	Møtrik Nut Mutter Ecrou		1	1	1	1
47	6200651	Slangestuds Hose socket Schlauchstutzen Raccord du tuyau		1	1	1	1
-	1803329	Kabelbinder sort Clamp black Schelle schwarz Collier de serrage noir		3	3	3	3
-	1802347	Kabelbinder hvid Clamp white Schelle weiss Collier de serrage blanc		3	3	3	3

598 75 99 - Jun. 2004

⚠ ATTENTION! - Lengths in metres - Please indicate required length when ordering! ⚠ ATTENTION! - Longueurs par mètre - Préciser la longueur à la commande!  
⚠ ACHTUNG! - Maße in Metern - Bitte bei Bestellung gewünschte Länge angeben! ⚠ ACHTUNG! - Maße in Metern - Bitte bei Bestellung gewünschte Länge angeben!

**Blødgøringspumpe / Pump f. softener**  
**Pumpe f. Enthärter / Pompe adoucisseur d'eau**

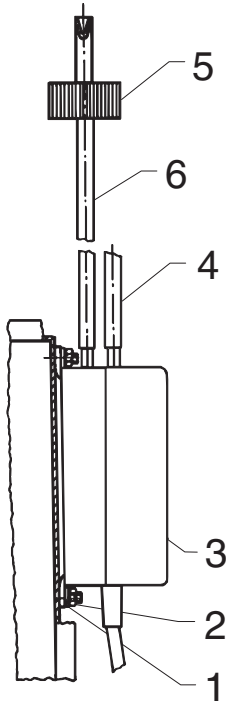

**Indsugningsstuds / Suction branch**  
**Einlaßstutzen / Raccord d'aspiration**  
 ⇒ 07.03.89 |

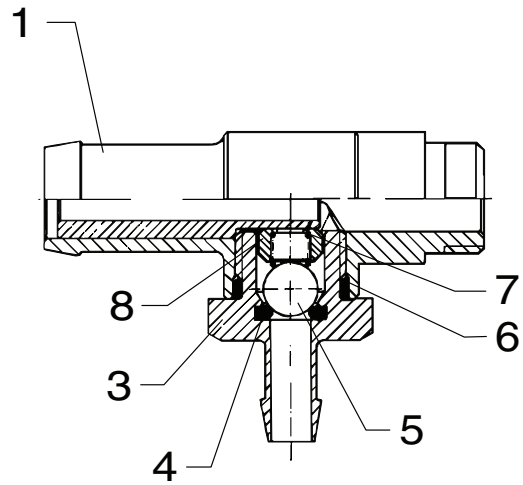

**Kemisystem / Chemical dosing / Chemiedosierung / Dosage détergent**

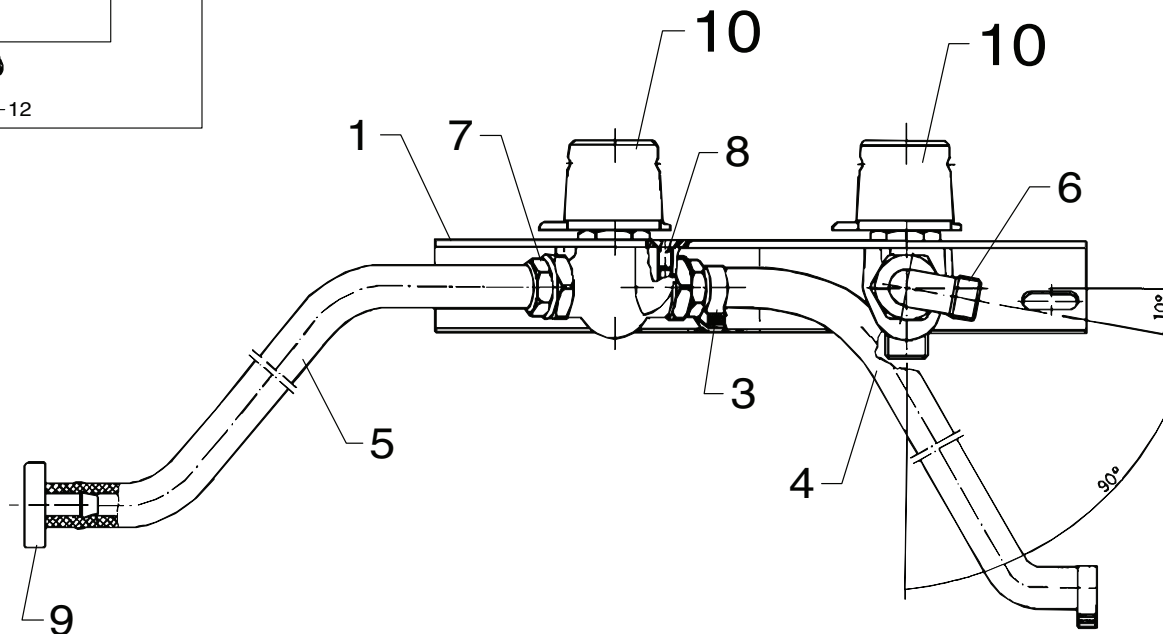
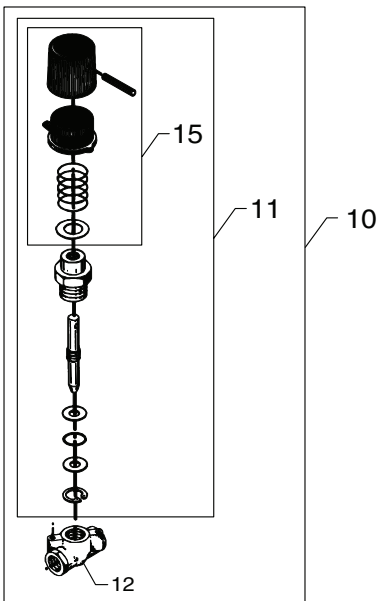

598 75 99 - Jun. 2004

Pos. Ref.	Nr. No.	Betegnels Bezeichnung	Designation Désignation	16A2V/VA	23A2V/VA	26A2V/VA	38A2V/VA
-	6401064	Blødgøringspumpe, kompl. Pump f. softener, compl. Pumpe f. Enthärter, kompl. Pompe adoucisseur d'eau, compl.		x	x	x	x
1	1800887	Skive Washer Scheibe Rondelle		2	2	2	2
2	1800127	Låsemøtrik Lock nut Gegenmutter Ecroû de blocage		2	2	2	2
<b>3</b>	<b>3812468</b>	<b>Doserpumpe, kompl. Dosing pump, compl. Dosierpumpe, kompl. Pompe de dosage, compl.</b>		<b>1</b>	<b>1</b>	<b>1</b>	<b>1</b>
4	5206388 ⌘	Afgangsslange Outlet hose Auslassschlauch Flexible (sortie)	(L=525)	1	1	1	1
5	6200658	Låg for dunk Cover for container Deckel für Behälter Couvercle du bidon		1	1	1	1
6	5206388 ⌘	Tilgangsslange Inlet hose Einlassschlauch Flexible (admission)	(L=1260)	1	1	1	1
-	6209071	Betjeningsvejledning Instructions for use Gebrauchsanleitung Notice d'utilisation		1	1	1	1
-	-	<b>Indsugningsstuds, kompl. Suction branch Einlassstutzen, kompl. Raccord d'aspiration, compl.</b>	⇒ 07.03.89	x	x	x	x
1	6200564	Studs Socket Stutzen Raccord		1	1	1	1
3	3400512	Kontraventil Non return-valve Rückschlagventil Clapet anti-retour		1	1	1	1
4	3000296	O-ring O-ring O-Ring Joint torique		1	1	1	1
5	3400447	Kugle Ball Kugel Bille		1	1	1	1
6	3000064	O-ring O-ring O-Ring Joint torique		1	1	1	1
7	2600468	Fjeder Spring Feder Ressort		1	1	1	1
8	6200541	Fjederstyr Valve guide Federführung Guide ressort		1	1	1	1

Pos. Ref.	Nr. No.	Betegnels Bezeichnung	Designation Désignation	16A2V/VA	23A2V/VA	26A2V/VA	38A2V/VA
-	-	<b>Kemisystem, kompl. Chemical dosing, compl. Chemiedosierung, kompl. Dosage détergent, compl.</b>		x	x	x	x
1	6200081	Instrumentplade Control panel Armaturenbrett Tableau de commande	<b>A2V</b>	1	1	1	1
-	6201905	Instrumentplade Control panel Armaturenbrett Tableau de commande	<b>A2VA</b>	1	1	1	1
3	1810084	Spændebånd Hose clip Schlauchschele Collier de serrage		2	2	2	2
4	5206388 ⌘	Slange Hose Schlauch Flexible	(L = 320)	1	1	1	1
5	5206636 ⌘	Slange Hose Schlauch Flexible	(L = 2212)	1	1	1	1
6	1602416	Vinkel Elbow Winkel Coude	<b>A2VA</b>	2	2	2	2
7	1600527	Slangestuds Hose socket Schlauchstutzen Raccord du tuyau		2	2	2	2
8	1801612	Skrue Screw Schraue Vis		2	2	2	2
9	6400240	Kemifilter Chemical filter Chemiefilter Filtre de détergent		1	1	1	1
<b>10</b>	<b>1111913</b>	<b>Doserventil, kompl. Dosing valve, compl. Dosierventil, kompl. Vanne de dosage, compl.</b>		<b>x</b>	<b>x</b>	<b>x</b>	<b>x</b>
<b>11</b>	<b>1400811</b>	<b>Spindel, kompl. Spindle, compl. Spindel, kompl. Broche, compl.</b>		<b>1</b>	<b>1</b>	<b>1</b>	<b>1</b>
12	3401148	Hus Housing Gehäuse Carter		1	1	1	1
<b>15</b>	<b>6008041</b>	<b>Rep. sæt, greb Rep. kit, handle Rep.satz, Griff Kit de rép., poignée</b>		<b>1</b>	<b>1</b>	<b>1</b>	<b>1</b>

A 1119017  
 B 1119037  
 C 1119310  
 D 1119101  
 E 1119013  
 F 1119038

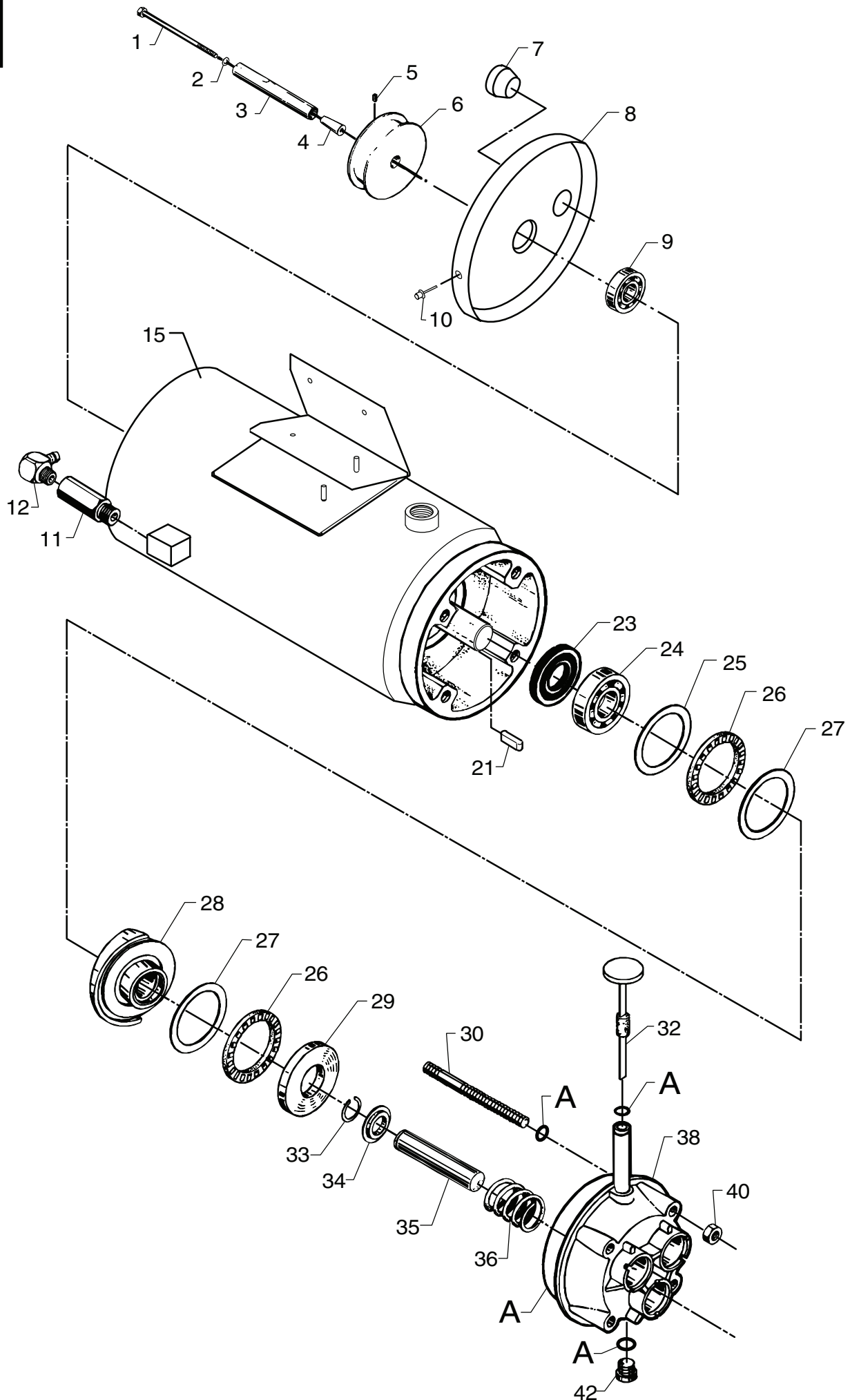

598 75 99 - Jun. 2004

Pos. Ref.	Nr. No.	Betegnels Bezeichnung	Designation Désignation	16A2V/VA	23A2V/VA	26A2V/VA	38A2V/VA
-	-	<b>Motorpumpeenhed, komp. Motor/pump unit, compl. Motorpumpeneinheit, kompl. Corps de moteur/pompe, compl.</b>		x	x	x	x
1	6200415	Bolt Stud Bolzen Boulon	⇒ 01.11.89	1	1	1	1
2	1802727	Skive Washer Scheibe Rondelle	⇒ 01.11.89	1	1	1	1
3	6200413	Aksel Shaft Welle Arbre	⇒ 01.11.89	1	1	1	1
4	6200414	Konus Cone Kegel Cône	⇒ 01.11.89	1	1	1	1
5	1800358	Skrue Screw Schraube Vis	⇒ 01.11.89	1	1	1	1
6	6200434	Remskive Pulley Riemenscheibe Poulie	50Hz	1	1	1	1
6	6200435	Remskive Pulley Riemenscheibe Poulie	60Hz	1	1	1	1
7	3808276	Pakdåse Cable grommet Stopfbuchse Presse-étoupe		1	1	1	1
8	6105485	N-lejedæksel Rear bearing cover N-Lagerdeckel AR-flasque de carter		1	1	1	1
9	3200870	Kugleleje Ball bearing Kugellager Roulement à bille		1	1	1	1
10	1813260	Popnitte Rivet Niet Rivet		2	2	2	2
11	2200293	Studs Socket Stutzen Raccord		1	1	1	1
12	6101752	Vinkel Elbow Winkel Coude		1	1	1	1
<b>15</b>	-	<b>Motor, komplet Motor, complete Motor, komplett Moteur, compl.</b>		<b>Se side 19 See page 19 SieheSeite 19 Voir page 19</b>			
21	3200789	Feder Key Federkeil Clavette		1	1	1	1
23	3001872	Olietætningsring Oil gasket Öldichtungsring Joint d'huile		1	1	1	1
24	3200888	Kugleleje Ball bearing Kugellager Roulement à bille		1	1	1	1
25	3200896	Lejering Bearing ring Ring f. Lager Rondelle		1	1	1	1
26	3200912	Nåleleje Needle bearing Nadellager Roulement à aiguille		2	2	2	2

Pos. Ref.	Nr. No.	Betegnels Bezeichnung	Designation Désignation	16A2V/VA	23A2V/VA	26A2V/VA	38A2V/VA
27	3200904	Lejering Bearing ring Ring f. Lager Rondelle		2	2	2	2
28	-	Skråskive Wobble disc Taumelscheibe Disque oblique					
-	6105503	A	60Hz	1			
-	6105504	B	50Hz (23A2V/VA 60Hz)	1	1		
-	6105505	C	(26A2V/VA, 50Hz) 60Hz			1	1
-	6105506	D	50Hz			1	1
29	6105499	Lejeskive Bearing track Lagerscheibe Rondelle de palier		1	1	1	1
30	6105480	Stagbolt L=130mm Stay bolt Stehbolzen Entretoise		4	4	4	4
32	6105375	Oliepind Oil gauge pin Ölauffüllrohr Orifice de remplissage d'huile		1	1	1	1
33	1803162	Låsering Circlip Sicherungsring Circlip		3	3	3	3
34	6105521	Ring til returfeder Ring for return spring Ring für Rückzugfeder Anneau p. ressort de rap.		3	3	3	3
35	6152604	Stempel Piston Druckkolben Piston				3	3
35	6150619	Stempel Piston Druckkolben Piston		3	3		
36	2600591	Returfeder Return spring Rückzugfeder Ressort de rappel		3	3	3	3
38	6105474	Cylinderblok Cylinder bloc Zylinderblock Carter-cylindre		1	1	1	1
40	1800465	Møtrik Nut Mutter Ecrou		6	6	6	6
42	6105533	Oliefaptningsprop Oil drain plug Ölablasspfropfen Bouchon de vidange huile		1	1	1	1

- A 1119017
- B 1119037
- C 1119310
- D 1119101
- E 1119013
- F 1119038

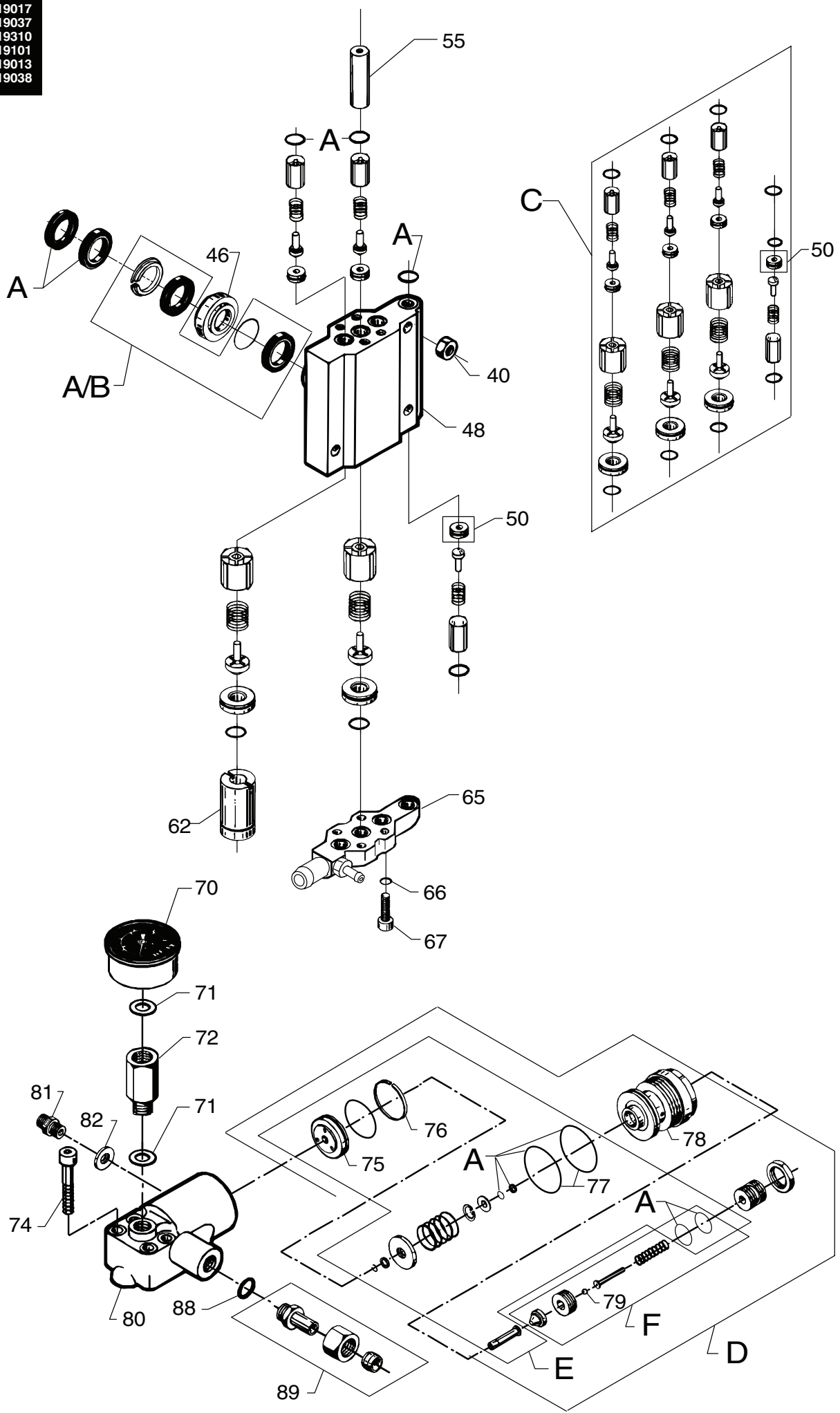

598 75 99 - Jun. 2004



Pos. Ref.	Nr. No.	Betegnelse Bezeichnung	Designation Désignation	16A2V/VA	23A2V/VA	26A2V/VA	38A2V/VA
<b>A</b>	1119017	Rep.sæt, pakninger Rep.kit, gaskets Rep.satz, Dichtungen Kit de joints		1	1	1	1
<b>B</b>	1119037	Rep.sæt, pakninger (red.) Rep.kit, gaskets (red.) Rep.satz, Dichtungen (red.) Kit de joints (réduit)		1	1	1	1
<b>C</b>	1119310	Rep.sæt, ventilsystem Rep.kit, valve system Rep.satz, Ventilsystem Kit de système de clapet		1	1	1	1
46	6150609	Trykring Thrust collar Druckring Anneau d'arrêt		1	1	1	1
48	6105476	Topstykke Cylinder head Zylinderkopf Culasse		1	1	1	1
50	6200568	Ventilsæde Valve seat Ventilsitz Siège du clapet	<b>16A2VA</b>	1			
-	6200567	Ventilsæde Valve seat Ventilsitz Siège du clapet	<b>23A2VA</b>		1		
-	6402307	Ventilsæde Valve seat Ventilsitz Siège du clapet	<b>26/38A2VA</b>			1	1
55	6150611	Afstandsstykke Spacer Zwischenstück Pièce d'espace		1	1	1	1
62	6105500	Afstandsstykke Spacer Zwischenstück Pièce d'espace		2	2	2	2
65	6200573	Indsugningsdæksel Suction cover Einlassdeckel Couvercle d'aspiration		1	1	1	1
66	1801182	Skive Washer Scheibe Rondelle		4	4	4	4
67	1803337	Sætskrue Set screw Gewindestift Vis		4	4	4	4
70	3600996	Manometer Pressure gauge Manometer Manomètre		1	1	1	1
71	6105516	Nylonskive Nylon washer Nylonscheibe Rondelle nylon		1	1	1	1
72	6201651	Mellemstykke Spacer Zwischenstück Pièce d'espace	<b>A2V</b>	1	1	1	1
-	6201902	Forskrunding Threaded connection Verschraubung Raccord fileté	<b>A2VA</b>	1	1	1	1
74	1804590	Skrue Screw Schraube Vis		4	4	4	4
75	6105523	Ventilstempel Valve piston Ventilkolben Piston (de la soupape)		1	1	1	1
76	6150693	Stempelring Ring f. piston Ring f. Kolben Anneau piston		1	1	1	1

Pos. Ref.	Nr. No.	Betegnelse Bezeichnung	Designation Désignation	16A2V/VA	23A2V/VA	26A2V/VA	38A2V/VA
77	3001385	O-ring O-ring O-Ring Joint torique		1	1	1	1
78	6150642	Bundskrue Screw Schraube Vis		1	1	1	1
79	1600311	Kugle Ball Kugel Bille		1	1	1	1

- A 1119017
- B 1119037
- C 1119310
- D 1119101
- E 1119013
- F 1119038

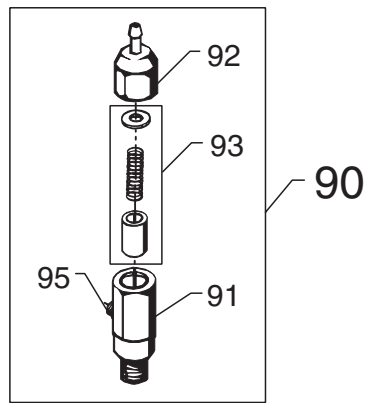
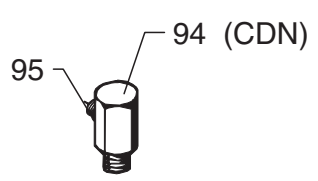
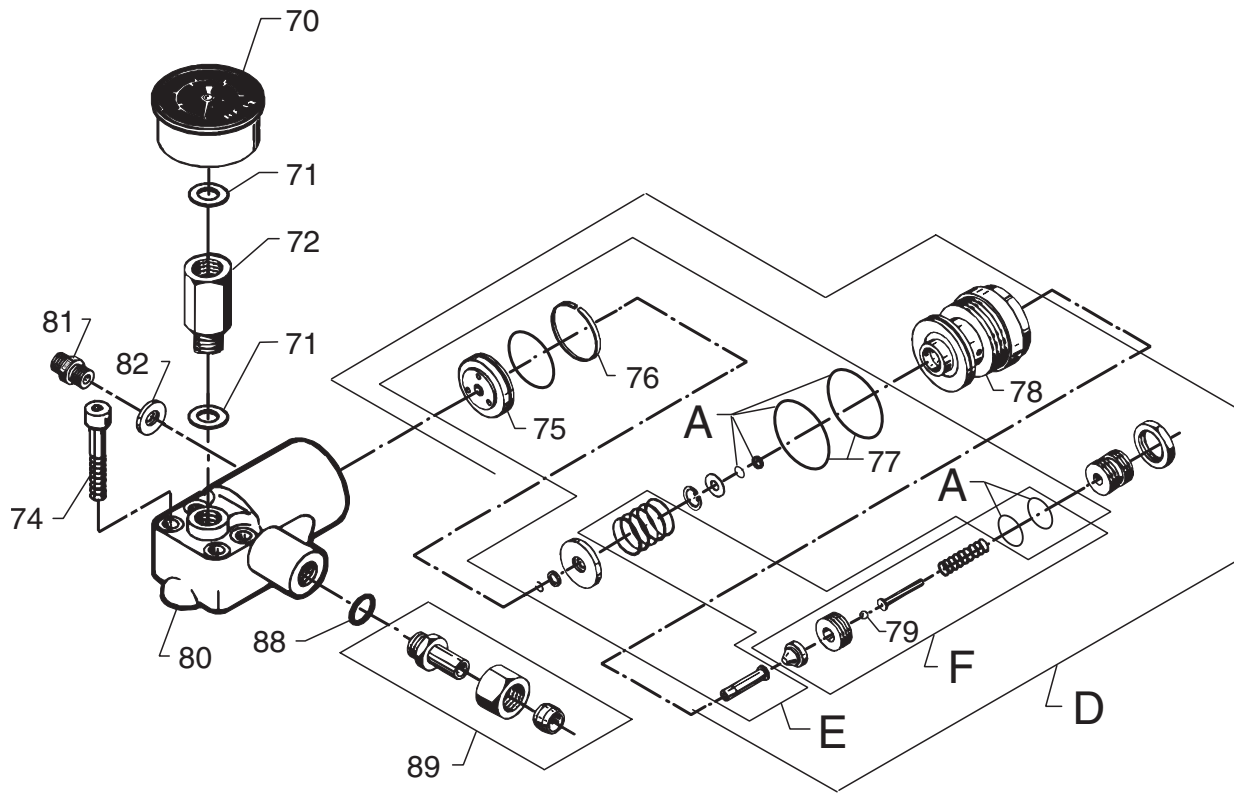

Pos. Ref.	Nr. No.	Betegnelse Bezeichnung	Designation Désignation	16A2V/VA	23A2V/VA	26A2V/VA	38A2V/VA
<b>D</b>	1119101	Rep.sæt, omløbsventil Rep.kit, by-pass valve Rep.satz, Umlaufventil Kit de soupape by-pass		1	1	1	1
<b>E</b>	1119013	Rep.sæt, omløbsventil Rep.kit, by-pass valve Rep.satz, Umlaufventil Kit de soupape by-pass		1	1	1	1
<b>F</b>	1119038	Rep.sæt, sikkerhedsventil Rep.kit, safety valve Rep.satz, Sicherheitsventil Kit de soupape de sûreté		1	1	1	1
80	6105528	Ventildæksel Valve cover Ventildeckel Couvercle de la soupape	<b>A2V</b>	1	1	1	1
-	6201903	Ventildæksel Valve cover Ventildeckel Couvercle de la soupape	<b>A2VA</b>	1	1	1	1
81	1602606	Forskruning Threaded connection Verschraubung Raccord fileté	<b>A2VA</b>	1	1	1	1
82	6201906	Afstandsskive Spacer Zwischenstück Pièce d'espace	<b>A2VA</b>	1	1	1	1
88	3000460	O-ring O-ring O-Ring Joint torique		1	1	1	1
89	6200558	Skæreringsforskruning Threaded connection Verschraubung Raccord fileté		1	1	1	1
<b>90</b>	<b>6221552</b>	* Udluftningsventil, kompl. Venting valve, compl. Entlüftungsventil, kompl. Vis de purge, compl.		x	x	x	x
91	6221526	Hus Housing Gehäuse Carter		1	1	1	1
92	6221529	Dæksel Cover Deckel Couvercle		1	1	1	1
<b>93</b>	1119317	Rep.sæt, udluftningsventil Rep.kit, venting valve Rep.satz, Entlüftungsventil Kit de rép., vis de purge		1	1	1	1
94	6200497	Forskruning Threaded connection Verschraubung Raccord fileté	<b>CDN</b>	1			
95	6200494	Dyse f. temp. reg. Nozzle f. temp. reg. Düse f. Temperaturregulierung Buse p. reg. de la temp.	<b>A2VA</b>	1			
-	6200495	Dyse f. temp. reg. Nozzle f. temp. reg. Düse f. Temperaturregulierung Buse p. reg. de la temp.	<b>A2VA</b>		1		
-	6200496	Dyse f. temp. reg. Nozzle f. temp. reg. Düse f. Temperaturregulierung Buse p. reg. de la temp.	<b>A2VA</b>			1	1

Pos. Ref.	Nr. No.	Betegnelse Bezeichnung	Designation Désignation	16A2V/VA	23A2V/VA	26A2V/VA	38A2V/VA
<b>15</b>	-	Motor, komplet Motor, complete Motor, komplett Moteur, compl.		x	x	x	x
-	6201652	60Hz, 3x440V 60Hz, 3x220V (USA) 50Hz, 3x380/220V					1 1 1
-	6201653	50Hz, 3x380V 50Hz, 3x380V 50Hz, 3x415-440V		1		1	1
-	6201654	50Hz, 1x240V 50Hz, 1x220V		1 1			
-	6201655	50Hz, 3x346/200V 60Hz, 3x200V				1 1	1 1
-	6201656	60Hz, 1x220V 60Hz, 1x220V		1	1		
-	6201657	60Hz, 1x115V		1			

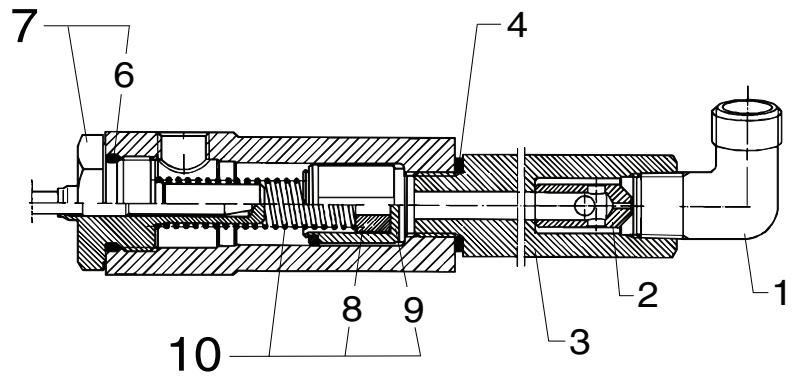

6228551

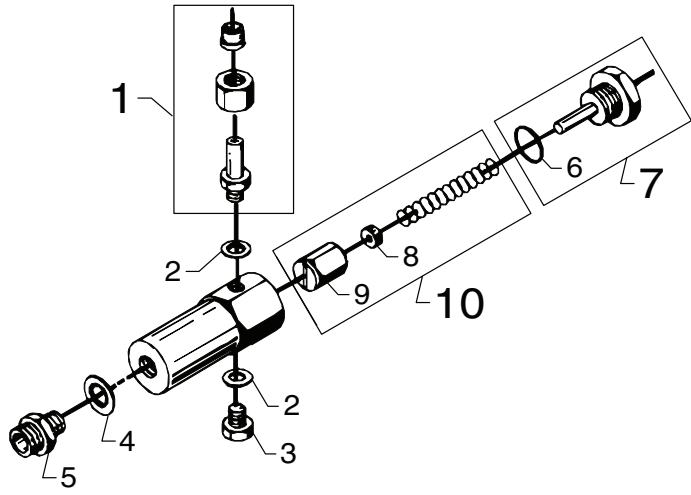

6200574

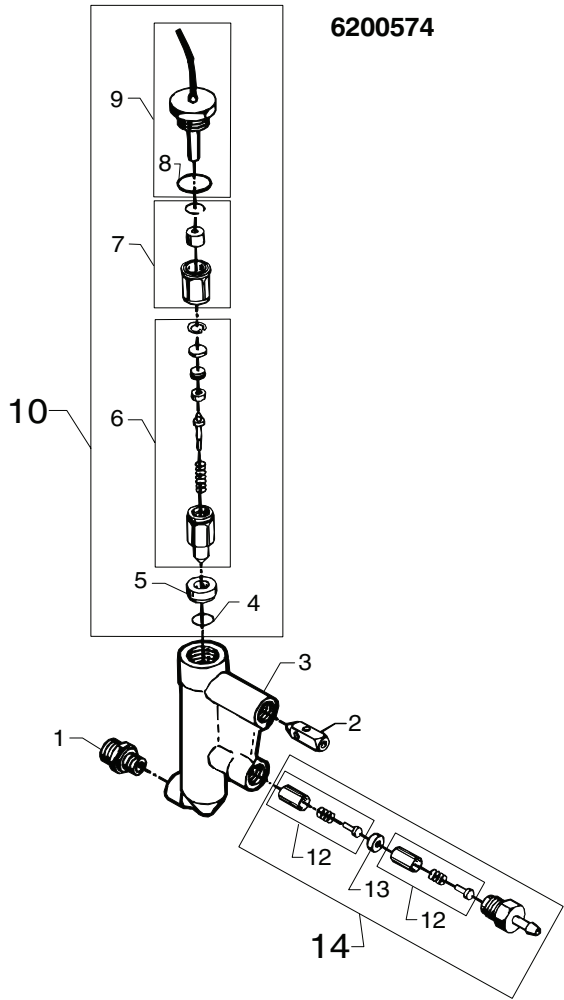

Pos. Ref.	Nr. No.	Betegnelse Bezeichnung	Designation Désignation	16A2V/VA	23A2V/VA	26A2V/VA	38A2V/VA
-	6200550	Strømningskontakt, pumpe Flow switch, pump	A2V	x	x	x	x
-	6200552	Strömungsschalter, Pumpe Circulation sélecteur	CDN (1x220V)	x	x	x	x
1	1600444 Winkel	Vinkel Elbow		1	1	1	1
		Coude					
2	6101038	Stempel Piston		1	1	1	1
		Kolben Piston					
3	6200537	Hus, kort Housing, short		1	1	1	1
		Gehäuse, kurz Corps, court					
-	6221257	Hus, lang Housing, long		1	1	1	1
		Gehäuse, lang Corps, long					
4	1801075	Tætningsskive Sealing washer		1	1	1	1
		Dichtungsscheibe Rondelle d'étanchéité					
6	3000825	O-ring O-ring		1	1	1	1
		O-Ring Joint torique					
7	6221773	Reedkontakt m. O-ring Reed switch with O-ring		1	1	1	1
		Reedschalter mit O-ring Reed sélecteur avec joint torique					
8	1803485	Magnet Magnet		1	1	1	1
		Magnet Aimant					
9	6200554	Stempel Piston		1	1	1	1
		Kolben Piston					
<b>10</b>	<b>1119701</b>	<b>Rep.sæt, strømningskontakt Rep.kit, flow switch Rep.satz, Strömungsschalter Kit de rép., circulation sélecteur</b>		<b>1</b>	<b>1</b>	<b>1</b>	<b>1</b>
-	6228551	Strømningskontrol Flow control, complete	A2V/VA	x	x	x	x
		Strömungswächter, komplett Contrôleur de débit, compl.					
1	6200558	Forskruning Threaded connection		1	1	1	1
		Verschraubung Raccord fileté					
2	1803493	Tætningsskive Sealing washer		2	2	2	2
		Dichtungsscheibe Rondelle d'étanchéité					
3	6200529	Aftapningsprop Drain plug		1	1	1	1
		Ablassschraube Bouchon					
4	1801075	Tætningsskive Sealing washer		1	1	1	1
		Dichtungsscheibe Rondelle d'étanchéité					
5	1601079	Forskruning Threaded connection		1	1	1	1
		Verschraubung Raccord fileté					
6	3000825	O-ring O-ring		1	1	1	1
		O-Ring Joint torique					
7	6221773	Reedkontakt m. O-ring Reed switch with O-ring		1	1	1	1
		Reedschalter mit O-ring Reed sélecteur avec joint torique					

Pos. Ref.	Nr. No.	Betegnelse Bezeichnung	Designation Désignation	16A2V/VA	23A2V/VA	26A2V/VA	38A2V/VA
8	1803485	Magnet Magnet		1	1	1	1
		Magnet Aimant					
9	6200554	Stempel Piston		1	1	1	1
		Kolben Piston					
<b>10</b>	<b>1119701</b>	<b>Rep.sæt, strømningskontakt Rep.kit, flow switch Rep.satz, Strömungsschalter Kit de rép., circulation sélecteur</b>		<b>1</b>	<b>1</b>	<b>1</b>	<b>1</b>
-	6200574	Strømningskontrol, komplet Flow control, compl.	01.02.90 ⇒	x	x	x	x
		Strömungswächter, komplett Contrôleur de débit, compl.					
1	1602770	Forskruning Threaded connection		1	1	1	1
		Verschraubung Raccord fileté					
2	6101038	Stempel Piston		1	1	1	1
		Kolben Piston					
3	6201545	Hus Housing		1	1	1	1
		Gehäuse Corps					
4	3001112	O-ring O-ring		1	1	1	1
		O-Ring Joint torique					
5	6201534	Sæde Seat		1	1	1	1
		Sitz Siège					
6	6350463	Stempel, kompl. Piston, compl.		1	1	1	1
		Kolben, kompl. Piston, compl.					
7	6350454	Stempel, kompl. Piston, compl.		1	1	1	1
		Kolben, kompl. Piston, compl.					
8	3000825	O-ring O-ring		1	1	1	1
		O-Ring Joint torique					
9	6221773	Reedkontakt m. O-ring Reed switch with O-ring		1	1	1	1
		Reedschalter mit O-ring Reed sélecteur avec joint torique					
<b>10</b>	<b>1119319</b>	<b>Rep.sæt, strømningskontrol Rep.kit, flow control Rep.satz, Strömungswächter Kit de rép., contrôleur de débit</b>		<b>1</b>	<b>1</b>	<b>1</b>	<b>1</b>
<b>12</b>	<b>1119566</b>	<b>Rep. sæt, kontraventil Rep. kit, nonreturn valve Rep. satz, Rückschlagventil Kit de rép., clapet anti-retour</b>		<b>2</b>	<b>2</b>	<b>2</b>	<b>2</b>
13	6201535	Sæde Seat		1	1	1	1
		Sitz Siège					
<b>14</b>	<b>1119318</b>	<b>Rep.sæt, kontraventil Rep.kit, nonreturn valve Rep.satz, Rückschlagventil Kit de rép., clapet anti retour</b>		<b>1</b>	<b>1</b>	<b>1</b>	<b>1</b>

6200939

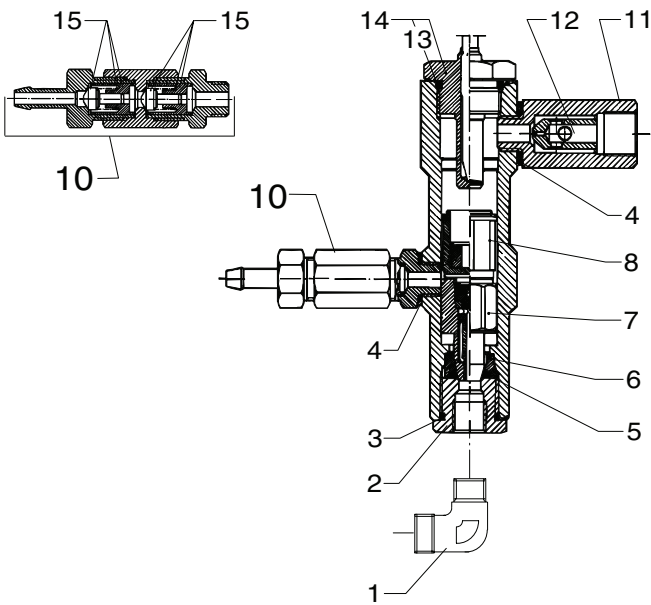

(N, S)

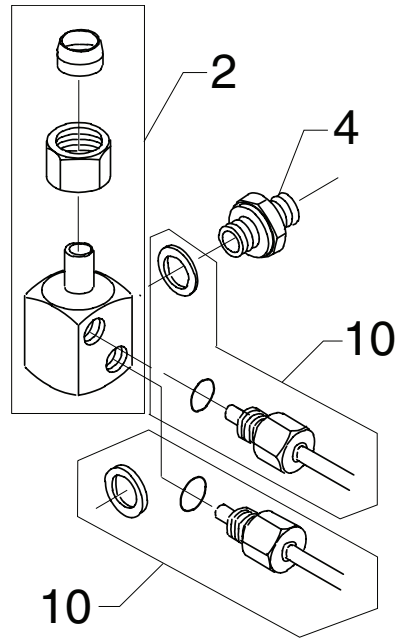

(CDN)

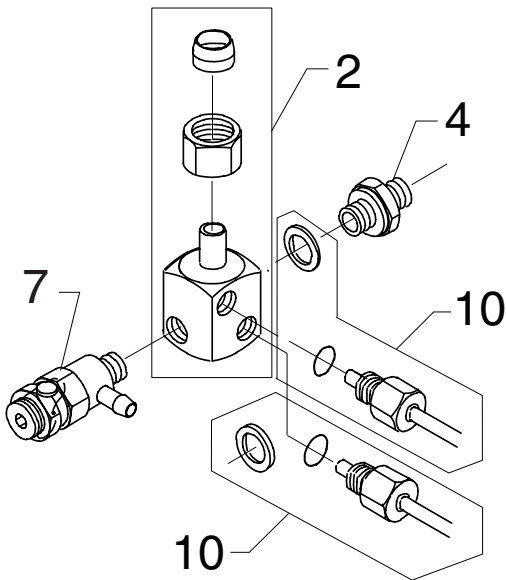

(AUS)

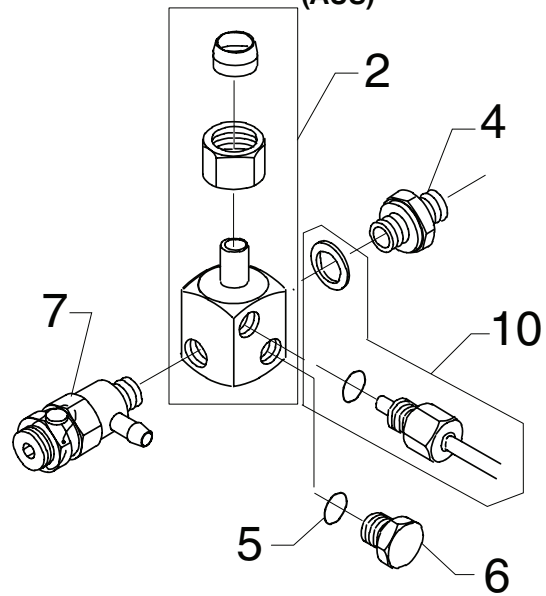

(SF)

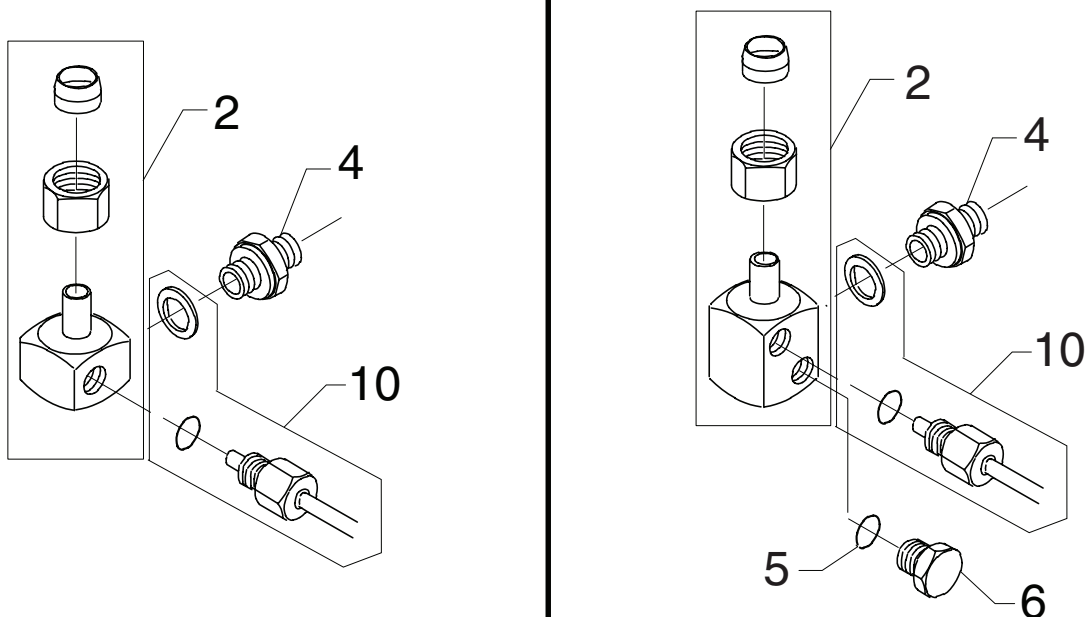

Pos. Ref.	Nr. No.	Betegnelse Bezeichnung	Designation Désignation	16A2/V/A	23A2/V/A	26A2/V/A	38A2/V/A
-	6200939	Strømningskontakt (start/stop) Flow switch (s/s) ⇒ 01.02.90   Strömungsschalter (Start/Stop) Circulation sélecteur (marche/arr.)		x	x	x	x
1	1603119	Vinkel Elbow Winkel Raccord coudé		1	1	1	1
2	6300438	Omløber Union nut Überwurfmutter Ecrou-raccord		1	1	1	1
3	3000262	O-ring O-ring O-Ring Joint torique		1	1	1	1
4	1803493	Tætningsskive Sealing washer Dichtungsscheibe Rondelle d'étanchéité		2	2	2	2
5	3001112	O-ring O-ring O-Ring Joint torique		1	1	1	1
6	6350625	Sæde Seat Sitz Siège		1	1	1	1
7	6350463	Stempel, kompl. Piston, kompl. Kolben, kompl. Piston, kompl.		1	1	1	1
8	6350454	Stempel, kompl. Piston, kompl. Kolben, kompl. Piston, kompl.		1	1	1	1
<b>10</b>	<b>6200938</b>	<b>Kontraventil, kompl. Nonreturn valve, compl. Rückschlagventil, kompl. Clapet anti-retour, compl.</b>		<b>1</b>	<b>1</b>	<b>1</b>	<b>1</b>
11	6220530	Hus Housing Gehäuse Corps		1	1	1	1
12	6101038	Stempel Piston Kolben Piston		1	1	1	1
13	3000825	O-ring O-ring O-Ring Joint torique		1	1	1	1
14	6221773	Reedkontakt m. O-ring Reed switch with O-ring Reedschalter mit O-ring Reed sélecteur avec joint torique		1	1	1	1
<b>15</b>	<b>1119566</b>	<b>Rep. sæt, kontraventil Rep. kit, nonreturn valve Rep. satz, Rückschlagventil Kit de rép., clapet anti-retour</b>		<b>2</b>	<b>2</b>	<b>2</b>	<b>2</b>
-	6201358	Spiralafgangsvinkel, komplet Outlet for coil, elbow Auslass für Heizschlange, Winkel Sortie serpentin coudée, compl.	CDN	x	x	x	x
<b>2</b>	<b>6220368</b>	<b>Spiralafgangsvinkel Outlet for coil, elbow Auslass für Heizschlange Sortie serpentin coudée</b>		<b>1</b>	<b>1</b>	<b>1</b>	<b>1</b>
4	1601079	Forskruning Threaded connection Verschraubung Raccord fileté		1	1	1	1
7	6220583	Sikkerhedsventil Safety valve Überdruckventil Soupape de sûreté		1	1	1	1
<b>10</b>	<b>1119011</b>	<b>Rep.sæt, spiralafgangsvinkel Rep.kit, Outlet coil, elbow Satz, Auslass Heizschlange, Winkel Kit de rép., sortie serpentin coudée</b>		<b>2</b>	<b>2</b>	<b>2</b>	<b>2</b>

Pos. Ref.	Nr. No.	Betegnelse Bezeichnung	Designation Désignation	16A2/V/A	23A2/V/A	26A2/V/A	38A2/V/A
-	6228350	Spiralafgangsvinkel, komplet Outlet for coil, elbow, complete Auslass für Heizschlange, Winkel Sortie serpentin coudée, compl.		x	x	x	x
<b>2</b>	<b>6200360</b>	<b>Spiralafgangsvinkel Outlet for coil, elbow Auslass für Heizschlange Sortie serpentin coudée</b>		<b>1</b>	<b>1</b>	<b>1</b>	<b>1</b>
4	1601079	Forskruning Threaded connection Verschraubung Raccord fileté		1	1	1	1
<b>10</b>	<b>1119011</b>	<b>Rep.sæt, spiralafgangsvinkel Rep.kit, Outlet coil, elbow Satz, Auslass Heizschlange, Winkel Kit de rép., sortie serpentin coudée</b>		<b>1</b>	<b>1</b>	<b>1</b>	<b>1</b>
-	6228354	Spiralafgangsvinkel, komplet Outlet for coil, elbow Auslass für Heizschlange, Winkel Sortie serpentin coudée, compl.	N, S	x	x	x	x
<b>2</b>	<b>6200381</b>	<b>Spiralafgangsvinkel Outlet for coil, elbow Auslass für Heizschlange Sortie serpentin coudée</b>		<b>1</b>	<b>1</b>	<b>1</b>	<b>1</b>
4	1601079	Forskruning Threaded connection Verschraubung Raccord fileté		1	1	1	1
<b>10</b>	<b>1119011</b>	<b>Rep.sæt, spiralafgangsvinkel Rep.kit, Outlet coil, elbow Satz, Auslass Heizschlange, Winkel Kit de rép., sortie serpentin coudée</b>		<b>2</b>	<b>2</b>	<b>2</b>	<b>2</b>
-	6228357	Spiralafgangsvinkel, komplet Outlet for coil, elbow, complete f. AUS Auslass für Heizschlange, Winkel, komp. Sortie serpentin coudée, compl.		x	x	x	x
<b>2</b>	<b>6220368</b>	<b>Spiralafgangsvinkel Outlet for coil, elbow Auslass für Heizschlange Sortie serpentin coudée</b>		<b>1</b>	<b>1</b>	<b>1</b>	<b>1</b>
4	1601079	Forskruning Threaded connection Verschraubung Raccord fileté		1	1	1	1
6	6200491	Prop Plug Pfropfen Bouton		1	1	1	1
7	6220584	Sikkerhedsventil Safety valve Überdruckventil Soupape de sûreté		1	1	1	1
<b>10</b>	<b>1119011</b>	<b>Rep.sæt, spiralafgangsvinkel Rep.kit, Outlet coil, elbow Rep.satz, Auslass Heizschlange, Winkel Kit de rép., sortie serpentin coudée</b>		<b>1</b>	<b>1</b>	<b>1</b>	<b>1</b>
-	6228355	Spiralafgangsvinkel, komplet Outlet for coil, elbow Auslass für Heizschlange, Winkel Sortie serpentin coudée, compl.	SF	x	x	x	x
<b>2</b>	<b>6200381</b>	<b>Spiralafgangsvinkel Outlet for coil, elbow Auslass für Heizschlange Sortie serpentin coudée</b>		<b>1</b>	<b>1</b>	<b>1</b>	<b>1</b>
4	1601079	Forskruning Threaded connection Verschraubung Raccord fileté		1	1	1	1
5	3000973	O-ring O-ring O-Ring Joint torique		1	1	1	1
6	6200491	Prop Plug Pfropfen Bouton		1	1	1	1
<b>10</b>	<b>1119011</b>	<b>Rep.sæt, spiralafgangsvinkel Rep.kit, Outlet coil, elbow Satz, Auslass Heizschlange, Winkel Kit de rép., sortie serpentin coudée</b>		<b>2</b>	<b>2</b>	<b>2</b>	<b>2</b>

Kedel / Boiler / Kessel / Chaudière

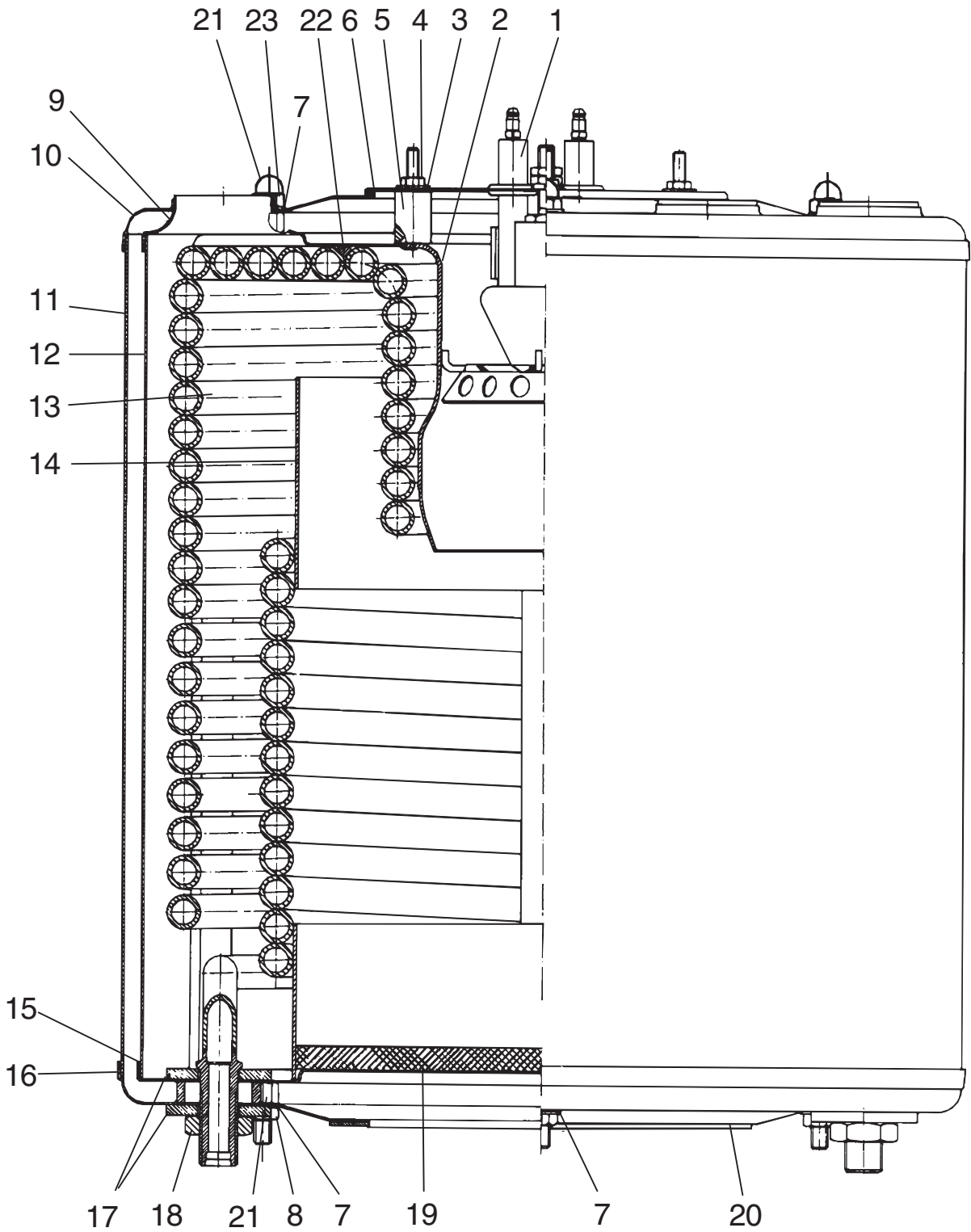



Pos. Ref.	Nr. No.	Betegnels Bezeichnung	Designation Désignation	16A2V/VA	23A2V/VA	26A2V/VA	38A2V/VA
5	-	Kedel, komplet Boiler, complete Kessel, komplett Chaudière, compl.		x	x	x	x
1	-	Lufftdelers, komplet Air distributor, complete Luftverteiler, komplett Distributeur d'air, compl.		Se side 27 See page 27 Siehe Seite 27 Voir page 27			
2	6200350	Brænderrør Burner tube Brennrør Tube du brûleur		1	1	1	1
-	6201353	Brænderrør Burner tube Brennrør Tube du brûleur	CDN	1			
3	1800440	Skive Washer Scheibe Rondelle	M6	3	3	3	3
-	1800903	Skive Washer Scheibe Rondelle	CDN	3			
4	1800705	Møtrik Nut Mutter Écrou	M6	3	3	3	3
5	6200281	Afstandsstykke Spacer Zwischenstück Pièce d'espace		3	3	3	3
6	3001104	O-ring O-ring O-Ring Joint torique	ø 164,3x3	1	1	1	1
7	1800796	Skive Washer Scheibe Rondelle	M8	7	7	7	7
8	1803725	Møtrik Nut M8 Mutter Écrou		3	3	3	3
9	6200354	Kedeltop, indvending Boiler, top section, inner Kessel, oberer Teil, innen Chaudière, part sup., intérieure		1	1	1	1
10	6200250	Kedeltop, udvendig Boiler, top section, outer Kessel, oberer Teil, aussen Chaudière, part sup., extérieure		1	1	1	1
11	6200256	Ydersvøb Outer jacket Aussenmantel Jupe externe		1	1	1	1
12	6200255	Indersvøb Inner jacket Innenmantel Jupe interne		1	1	1	1
13	-	Spiral Coil Heizschlange Serpentin		1	1	1	1
-	6200390	Gul, yellow, gelb, jaune		1	1	1	
-	6201359	Hvid, white, weiss, blanc					1
14	-	Flammerør Flame tube Flammrohr Tube à flammes		1	1	1	1
-	6200389	38A2V/VA					1
-	6200359	16-23-26A2V/VA		1	1	1	
15	6200253	Kedelbund, indvending Boiler, bottom sect., inner Kessel, Unterteil, innen Chaudière, fond, intérieur		1	1	1	1

Pos. Ref.	Nr. No.	Betegnels Bezeichnung	Designation Désignation	16A2V/VA	23A2V/VA	26A2V/VA	38A2V/VA
-	6220277	Kedelbund, indvending Boiler, bottom sect., inner Kessel, Unterteil, innen Chaudière, fond, intérieur	CDN	1			
16	6200355	Kedelbund, udvendig Boiler, bottom sect., outer Kessel, Unterteil, aussen Chaudière, fond, extérieur		1	1	1	1
-	6220367	Kedelbund, udvendig Boiler, bottom sect., outer Kessel, Unterteil, aussen Chaudière, fond, extérieur	CDN	1			
17	6200273	Skive Washer Scheibe Rondelle		4	4	4	4
18	1803220	Kontramøtrik Lock nut Gegenmutter Contre écrou	M 18x1,5	2	2	2	2
19	6240257	Isolering Insulating covering Isolierschicht Isolant		1	1	1	1
20	6200282	Pakning Gasket Dichtung Joint		1	1	1	1
21	6200286	Møtrik Nut Mutter Écrou		6	6	6	6
22	6200299	Paksnor Gasket (cord) Dichtungsschnur Ficelle de garniture	L=700	1	1	1	1
23	1807528	Møtrik Nut Mutter Écrou	M 8	3	3	3	3
24	1801026	Møtrik Nut Mutter Écrou	CDN	1			
25	3001427	Gennemføring Lead-in bush Durchführungsstülpe Traversée	CDN	1			
26	6220275	Drænstuds Drain socket Ablassstutzen Raccord (vidange)	CDN	1			

Luftfordeler / Air distributor / Luftverteiler / Distributeur d'air

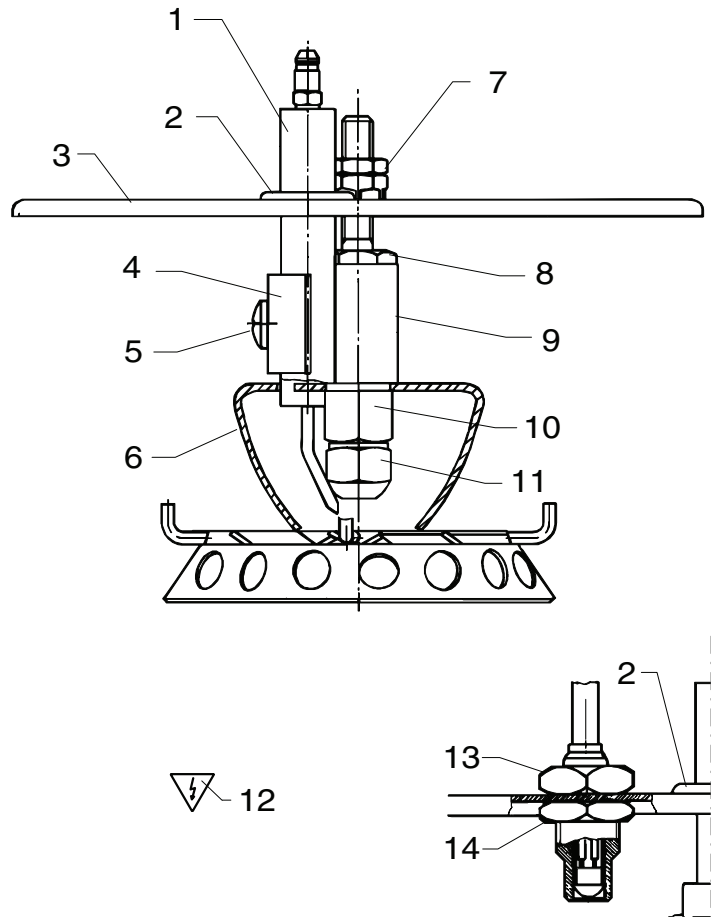

CDN

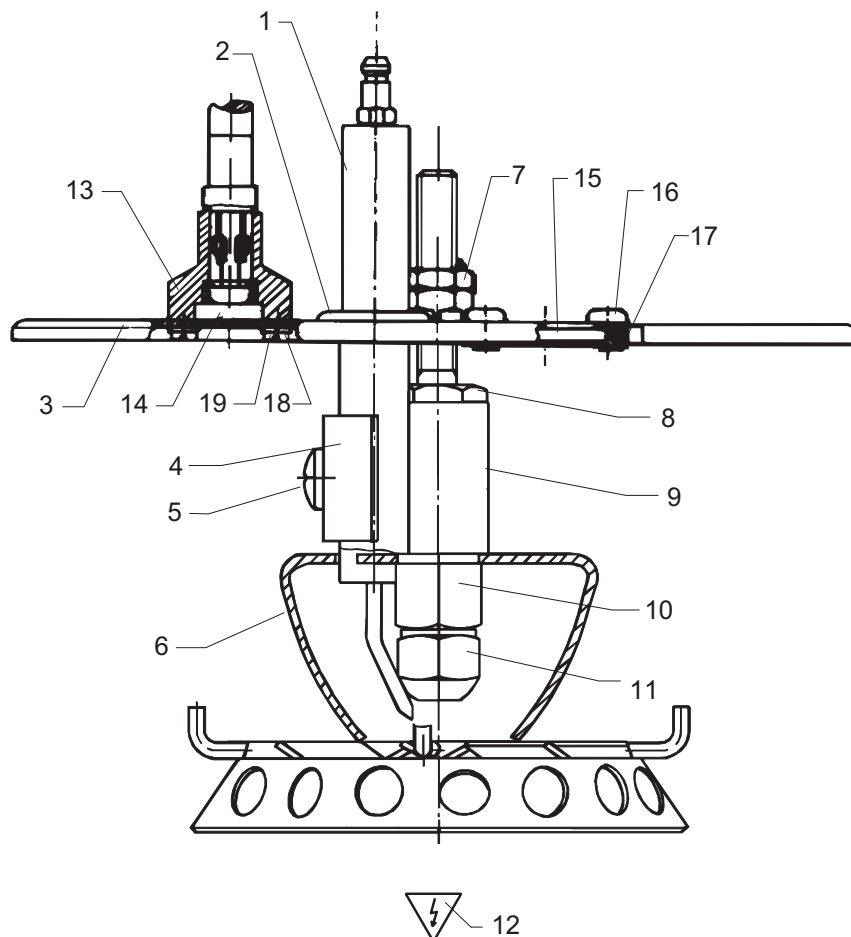

Pos. Ref.	Nr. No.	Betegnelse Bezeichnung	Designation Désignation	16A2V/VA	23A2V/VA	26A2V/VA	38A2V/VA
-	6200367	Luftfordeler, kompl. Air distributor Luftverteiler, komplett Distributeur d'air, compl.	⇒ 01.10.94	x	x	x	x
-	6200375	Luftfordeler m. føler, komplet Air distributor w. sensor, compl. Luftverteiler m. Fühler, komplett Distributeur d'air a. sonde, compl.				x	
-	6201354	Luftfordeler m. føler, komplet Air distributor w. sensor Luftverteiler m. Fühler, komplett Distributeur d'air a. sonde, compl.	CDN	x			
1	6200298	Tændelegode Initiating electrode Zündelegode Electrode		1	1	1	1
-	6220264	Tændelegode Initiating electrode Zündelegode Electrode	CDN	1			
2	3001427	Gennemføringsbøsning Rubber lead-in Gummidichtung Support de caoutchouc		2	2	2	2
3	6200364	Dæksel Cover Deckel Couvercle	CDN ⇒ 01.10.94	1	1	1	1
3	6200373	Dæksel til luftfordeler m. føler Cover for air distributor w. sensor Deckel für Luftverteiler m. Fühler Couvercle p. distrib. d'air a. sonde		1	1	1	1
4	6200260	Bøjle Clamp Bügel Collier		1	1	1	1
5	1801273	Skrue Screw Schraube Vis	M 6x12	1	1	1	1
6	6200365	Luftfordeler Air distributor Luftverteiler Distributeur d'air		1	1	1	1
-	6220266	Luftfordeler Air distributor Luftverteiler Distributeur d'air	CDN	1			
7	1803402	Kontramøtrik Lock nut Gegenmutter Contre écrou	M 8x1	1	1	1	1
8	6200296	Møtrik Nut Mutter Écrou		1	1	1	1
9	6200297	Elektrodeholder Holder f. electrode Halter f. Elektrode Support d'électrode		1	1	1	1
10	6220250	Dyseholder Holder f. nozzle Düsensitz Support du buse		1	1	1	1
11	2800548	Dyse Nozzle Düse Buse	7,49 kg	1	1	1	1
12	4206082	Lynsymbol Symbol - lightning Symbol - Blitz Symbole - éclair		1	1	1	1
(13)	6201887	Smeltesikring, kompl. Fuse, compl. Schmelzsicherung, kompl. Fusible, compl.	D ⇒ 01.10.94	1	1	1	1
13	6220841	Føler f. flammeovervågning Sensor f. flame control Fühler f. Flammenüberwachung Sonde - contrôle flammes	CDN	1			

Pos. Ref.	Nr. No.	Betegnelse Bezeichnung	Designation Désignation	16A2V/VA	23A2V/VA	26A2V/VA	38A2V/VA
13	6200301	Føler f. flammeovervågning Sensor f. flame control Fühler f. Flammenüberwachung Sonde - contrôle flammes					1
14	1803535	Kontramøtrik Lock nut 1/4"x5 Gegenmutter Contre écrou					1
14	6220285	Glas f. flammeovervågning Transparent cover Transparenter Deckel Couvercle transparent	CDN	1			
15	6220273	Inspektionsglas Inspection glass Schauglas Couvercle d'inspection	CDN	1			
16	1800391	Skrue Screw Schraube Vis	CDN	2			
17	6220272	Brille Holder Halterung Support	CDN	1			
18	1801281	Skive Washer Scheibe Rondelle	CDN	2			
19	1803248	Skrue Screw Schraube Vis	CDN	2			

Bläser / Fan / Gebläse / Ventilateur

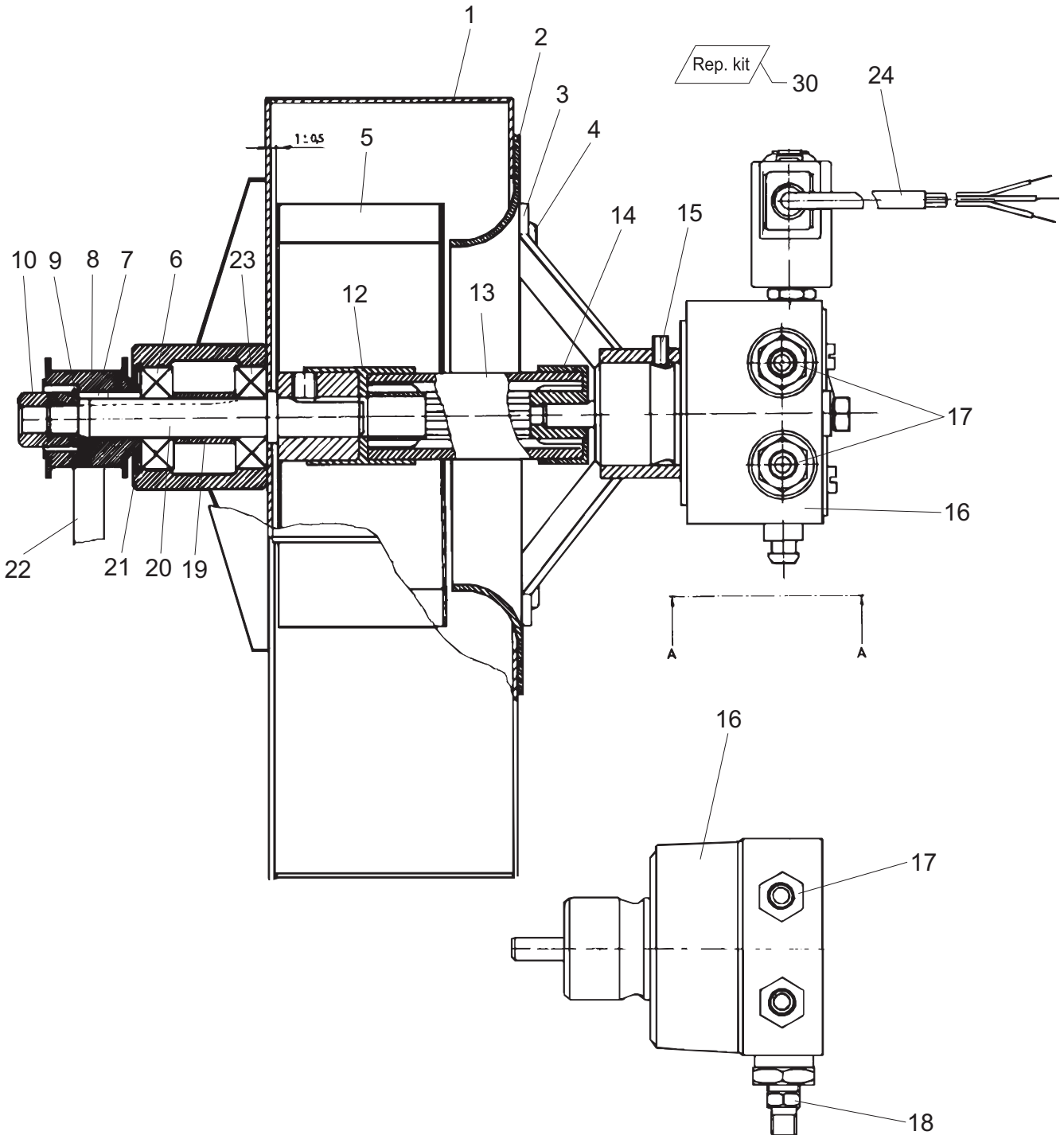

Pos. Ref.	Nr. No.	Betegnels Bezeichnung	Designation Désignation	16A2V/VA	23A2V/VA	26A2V/VA	38A2V/VA
-	-	<b>Blæser, komplet Fan, complete Gebläse, komplett Ventilateur, compl.</b>					
-	-	50 Hz		x		x	x
-	-	50Hz	<b>AUS, SGP, HK,NZ, E, F</b>	x			
-	-	50Hz	<b>GB</b>	x			
-	-	50Hz	<b>GB</b>				x
-	-	60Hz	<b>CDN</b>	x			
-	-	60 Hz	<b>J, USA, SJ, ROK, CN,SGP</b>			x	x
-	-	60 Hz	<b>USA</b>		x	x	
1	6200457	Blæserhus Fan housing Gehäuse für Gebläse Carter ventilateur		1	1	1	1
2	6200423	Indsugningstragt Suction funnel Saugtrichter Entonnoir d'aspiration		1	1	1	1
3	6200458	Oliepumpekonsol Bracket for fuel pump Stützplatte f. Brennstoffpumpe Support pompe à fuel		1	1	1	1
4	1803956	Taptite skrue Taptite screw Taptite Schraube Vis Taptite	<b>M4x12</b>	4	4	4	4
5	6200412	Blæserhjul Impeller Gebläserad Ventilateur		1	1	1	1
6	3200680	Kugleleje Ball bearing Kugellager Roulement à billes		1	1	1	1
7	3200995	Feder Key Federkeil Clavette		1	1	1	1
8	6200468	Remskive Pulley Riemenscheibe Poulie				1	1
-	6200469	Remskive Pulley Riemenscheibe Poulie		1	1		
9	1800309	Skive Washer Scheibe Rondelle		1	1	1	1
10	6200436	Møtrik Nut Mutter Ecrou	<b>M 10</b>	1	1	1	1
12	3800984	Kobling Coupling Kupplung Accouplement		1	1	1	1
13	3801008	Koblingslange Hose f. coupling Schlauch f. Kupplung Tuyau p. accouplement		1	1	1	1
14	3800992	Kobling Coupling Kupplung Accouplement		1	1	1	1
15	1801091	Skrue Screw Schraube Vis	<b>M 5x10</b>	1	1	1	1
16	3821320	Oliepumpe, m. spole Fuel pump, w. coil Brennstoffpumpe, m. Spule Pompe à fuel, a. bobine	<b>(Danfoss)</b>	1	1	1	1

Pos. Ref.	Nr. No.	Betegnels Bezeichnung	Designation Désignation	16A2V/VA	23A2V/VA	26A2V/VA	38A2V/VA
-	6184943	Oliepumpe, m. spole Fuel pump, w. coil Brennstoffpumpe, m. Spule Pompe à fuel, a. bobine	<b>CDN (Suntec)</b>	1	1	1	1
-	1119214	<b>Rep.sæt, filter &amp; pakning Rep.kit, filter &amp; gasket Rep.satz, Filter &amp; Dichtung Kit de rép., Filtre &amp; joint</b>	<b>(Suntec)</b>	x	x	x	x
-	1119217	<b>Rep.sæt, filter &amp; pakning Rep.kit, filter &amp; gasket Rep.satz, Filter &amp; Dichtung Kit de rép., Filtre &amp; joint</b>	<b>(Danfoss)</b>	x	x	x	x
-	1814045	Møtrik Nut Mutter Ecrou	<b>(Suntec)</b>	1	1	1	1
-	3820305	Spole Coil Spule Bobine	<b>(Suntec)</b>	1	1	1	1
-	3821089	Spole, med møtrik og skive Coil, with nut and washer Spule, mit Mutter und Scheibe Bobine, a. écrou + rondelle	<b>(Danfoss)</b>	1	1	1	1
17	1600527	Slangestuds Hose union Schlauchstutzen Raccord de tuyau		2	2	2	2
18	1603422	Forskruning Threaded connection Verschraubung Raccord fileté		1	1	1	1
19	6200409	Afstandsbøsning Spacer bushing Distanzbuchse Baque		1	1	1	1
20	6201402	Aksel Shaft Welle Arbre		1	1	1	1
21	1803477	Seegerring Seeger circlip ring Seeger-Ring Anneau Seeger		1	1	1	1
22	6200426	Fladrem Belt, 50Hz Riemen Courroie	<b>642x10 mm</b>	1	1	1	1
-	6200428	Fladrem Belt, 60Hz Riemen Courroie	<b>627x10 mm</b>	1	1	1	1
23	3201019	Kugleleje Ball bearing Kugellager Roulement à billes		1	1	1	1
24	3812872	Ledning f. oliepumpe Cable f. fuel pump Leitung f. Brennstoffpumpe Câble p. pompe à fuel				1	1
-	6200224	Remskærm Guard f. belt Schutzplatte f. Riemen Tôle protectrice de la courroie	<b>GB, AUS, HK, SGP, NZ</b>	1			

Svømmerhus / Float chamber / Schwimmergehäuse / Bac à flotteur

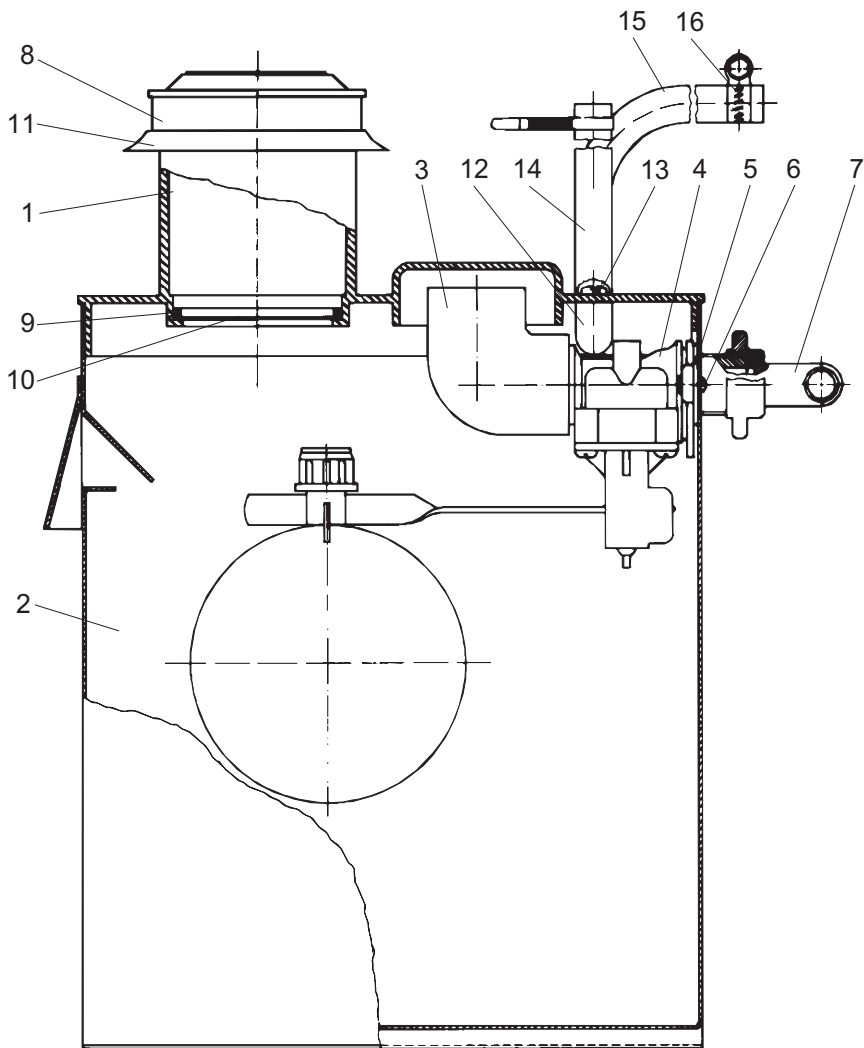



Betjeningspanel / Control panel / Armaturen Brett / Tableau de commande

Snit A-A

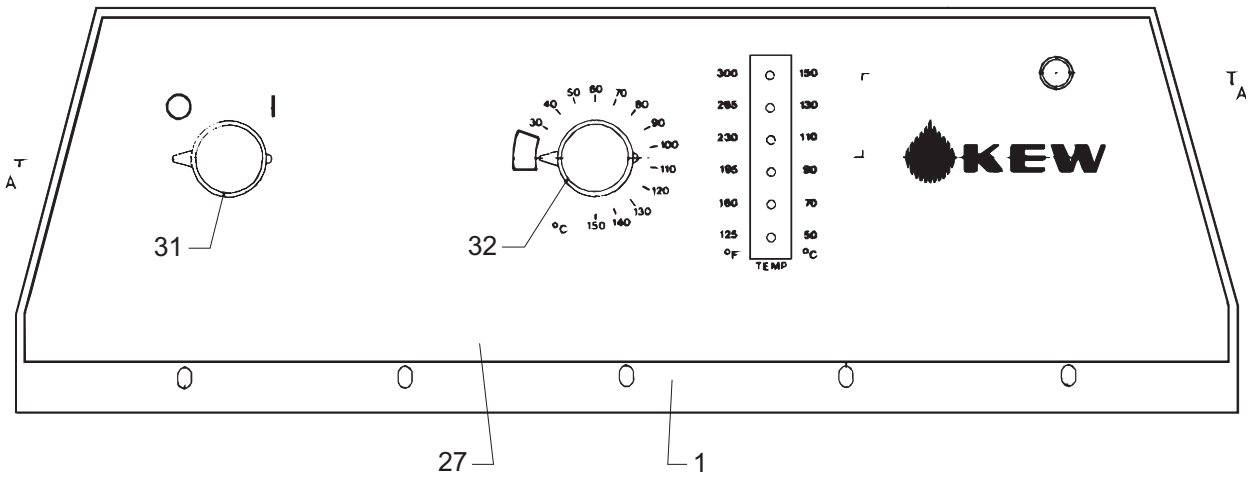
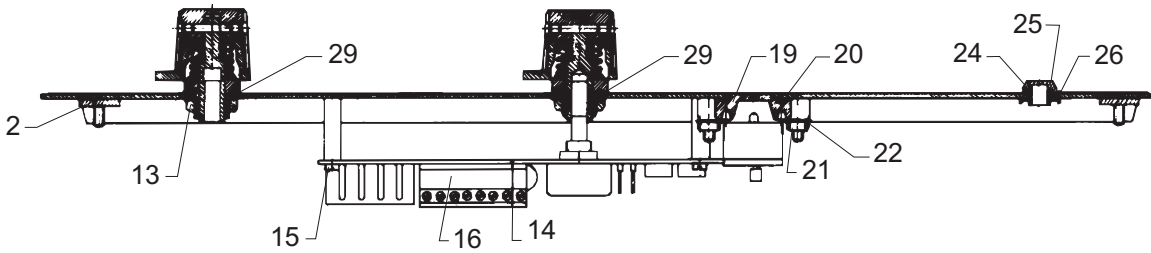



Pos. Ref.	Nr. No.	Betegnelse Bezeichnung	Designation Désignation	16A2V/VA	23A2V/VA	26A2V/VA	38A2V/VA
-	-	Betjeningspanel, monteret Control panel, mount. Armaturenbrett, montiert Tableau de commande, monté		x	x	x	x
-	6201850	A2V, 3~	⇒ 01.10.94				
-	6201849	A2V, 1~	⇒ 01.10.94				
-	6201842	A2V, CDN	1~				
-	6201854	A2VA, 3~	⇒ 01.10.94				
-	6201853	A2VA, 1~	⇒ 01.10.94				
-	6201852	med flammeovervågning with flame control mit Flammenüberwachung avec contrôle flammes	3~ A2V				
-	6201851	med flammeovervågning with flame control mit Flammenüberwachung avec contrôle flammes	1~ A2V				
-	6201856	med flammeovervågning with flame control mit Flammenüberwachung avec contrôle flammes	3~ A2VA				
-	6201855	med flammeovervågning with flame control mit Flammenüberwachung avec contrôle flammes	1~ A2VA				
1	6201767	Betjeningspanel Control panel Armaturenbrett Tableau de commande		1	1	1	1
-	6220843	Betjeningspanel Control panel Armaturenbrett Tableau de commande	CDN	1	1	1	1
2	6200745	Pakning Gasket Dichtung Joint		1	1	1	1
13	1803535	Møtrik Nut Mutter Ecrou		2	2	2	2
14	6420008	Print Circuit board Print Circuit imprimé	1~, 3~ ⇒ 01.10.94				
-	6420002	Print Circuit board Print Circuit imprimé	CDN, 1~				
-	6420009	Print, (flammeovervågning) Circuit board, (flame control) Print, (Flammenüberwachung) Circuit imprimé, (contrôle flammes)		1	1	1	1
15	1803139	Skrue Screw Schraube Vis		4	4	4	4
16	3817079	Printstik Plug for circuit board Printstecker Prise p. circuit imprimé	7 pol.				
-	3817087	Printstik Plug for circuit board Printstecker Prise p. circuit imprimé	8 pol.				
-	3817095	Printstik Plug for circuit board Printstecker Prise p. circuit imprimé	12 pol.				
19	6200729	Rude f. termometer Inspection glass f. thermometer Schauglas f. Thermometer Couvercle d'inspection, thermomètre		1	1	1	1
20	6201756	Pakning Gasket Dichtung Joint		1	1	1	1

Pos. Ref.	Nr. No.	Betegnelse Bezeichnung	Designation Désignation	16A2V/VA	23A2V/VA	26A2V/VA	38A2V/VA
21	1800697	Møtrik Nut Mutter Ecrou		4	4	4	4
22	1800887	Skive Washer Scheibe Rondelle		4	4	4	4
24	3805389	Rude f. glimlampe Inspection glass f. glow lamp Schauglas f. Glimmlampe Couvercle d'inspection, indicateur		1	1	1	1
25	6201774	Pakning Gasket Dichtung Joint		1	1	1	1
26	1803667	Låseskive Lock washer Federtellerscheibe Rondelle		1	1	1	1
27	6201771	Transfer Transfer Aufkleber Aotocollant	A2V 3~				
-	6201770	Transfer Transfer Aufkleber Aotocollant	A2V 1~				
-	6201772	Transfer Transfer Aufkleber Aotocollant	A2VA 3~				
-	6201758	Transfer Transfer Aufkleber Aotocollant	A2VA 1~				
29	3001468	Pakning Gasket Dichtung Joint		2	2	2	2
31	1117399	Start/stop kontakt, kompl. Start/stop switch, compl. Start/stopp-Schalter, kompl. Bouton marche/arret, compl.		1	1	1	1
32	1117381	Drejeknap, kompl. Adjusting knob, compl. Drehschalter, kompl. Interrupteur à rotation, compl.		1	1	1	1

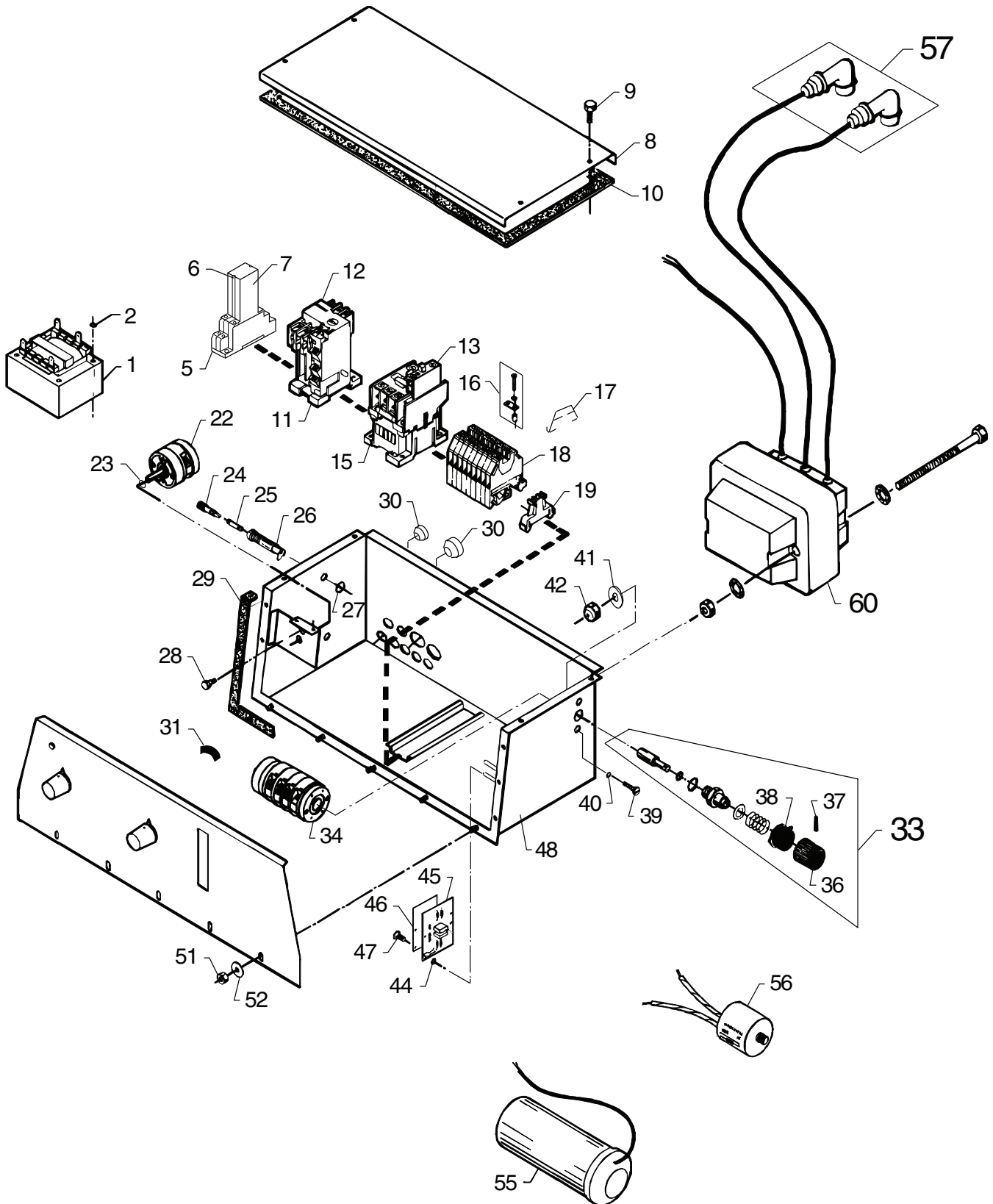

Pos. Ref.	Nr. No.	Betegnelse Bezeichnung	Designation Désignation	16A2V/VA	23A2V/VA	26A2V/VA	38A2V/VA
-	-	<b>Eldele</b> <b>Electrical components</b> <b>Elektrische Komponenten</b> <b>Éléments électriques</b>		x	x	x	x
1	-	Styretransformer Control transformer Steuerungstransformator Transformateur de commande	24V	1	1	1	1
-	3819851	220/380V	<b>I, B, N, SGP, E</b>				
-	3819786	380V					
-	3819794	415-440V	<b>GB, AUS</b>				
-	3819760	220V	<b>USA, SJ, CN, ROK, U</b>				
-	3819778	220-240V	<b>GB, AUS, SGP, HK</b>				
-	3819844	200V	<b>J</b>				
-	3811890	115V	<b>CDN</b>				
-	3808177	220V	<b>CDN</b>				
2	1805563	Låseskive Lock washer Sicherungsscheibe Disque de blocage		2	2	2	2
5	3812633	Relæsokkel Socket for relay Sockel für Relais Socle p. relais		1	1	1	1
6	3812658	Fjederklemme Terminal point Klemme Borne		2	2	2	2
7	3812641	Flammerelæ Relay for flame control Relais für Flammenüberwachung Relais pour contrôle flamme		1	1	1	1
8	6200734	Låg Cover Deckel Couvercle		1	1	1	1
9	1803956	Skrue Screw Schraube Vis		4	4	4	4
10	6200744	Pakning Gasket Dichtung Joint		1	1	1	1
11	3811643	Relæsokkel Socket for relay Sockel für Relais Socle p. relais					
12	-	Termorelæ Thermal relay Thermorelais Relais thermique					
-	3806551	CT 12-17,5A	⇒ 31.12.99	1		1	1
-	3811635	CT3-2, (ROK, CN, SJ)	⇒ 31.12.99			1	(1)
-	3821736	193-EA4GB	01.01.00 ⇒	1		1	1
-	3811627	CT3-12, GB					1
-	101119416	Rep. kit, CT3-32, USA, CDN 115V		1	1		
13	3805280	Hjælpekontakt Auxiliary switch, CDN Hilfsschalter	⇒ 31.12.99				
-	3821738	Interrupteur	01.01.00 ⇒				
15	-	Kontaktor Contactor Schütz Contacteur	24V	1	1	1	1
-	3821404	CA3-16-10	⇒ 31.12.99				
-	3821732	16A 24V 50-60Hz	01.01.00 ⇒				
-	3804168	CA3-23-10	⇒ 31.12.99				
-	3821739	23A 24V 50-60Hz	01.01.00 ⇒				

Pos. Ref.	Nr. No.	Betegnelse Bezeichnung	Designation Désignation	16A2V/VA	23A2V/VA	26A2V/VA	38A2V/VA
16	3807534	To-polet laske Joint Bipolar Lasche, 2-polig Plaque - bipolaire		2	2	2	2
17	3807542	Klemmeafdækning Cover for terminal-screws Abdeckung f. Anschlussklemmen Couverture barrette à bornes		3	3	3	3
18	3807518	Rækkelemme Terminal screw Anschlussklemme		7	7	7	7
-	3807260	Borne	<b>1~, CDN, USA</b>				
19	3805249	Endeholder Holder Halter Support		1	1	1	1
22	3810124	Drejekontakt, on/off Rotary switch Drehschalter Interrupteur à rotation		1	1	1	1
23	3000460	O-ring O-ring O-Ring Joint torique		1	1	1	1
24	3812666	Sikringsholder Holder f. fuse Halter f. Sicherung Support fusible		1	1	1	1
25	3808250	Sikring Fuse 1,25 A 250V Sicherung Fusible		1	1	1	1
26	3812674	Sokkel m. møtrik Socket w. nut Sockel m. Mutter Socle a. écrou		1	1	1	1
27	3000460	O-ring O-ring O-Ring Joint torique		1	1	1	1
28	6200802	Skrue Screw Schraube Vis		1	1	1	1
29	6200745	Pakning Gasket Dichtung Joint		1	1	1	1
30	-	Gummipakdåse Cable grommet Stopfbuchse Presse-étoupe					
-	3803764	TET 5-7 C					
-	3803772	TET 7-10 C					
-	3803780	TET 10-14 C					
-	3803798	TET 14-20 C					
31	6101574	Skala f. omskifter Dial f. Reverser Skalen f. Umschalter Echelle p. inverseur	220/3800V				
<b>32</b>	<b>3805876</b>	<b>Omskifter, pos.33-40</b> <b>Reverser ref. 33-40</b> <b>Umschalter, pos. 33-40</b> <b>Inverseur, ref. 33-40</b>		x	x	x	x
<b>33</b>	<b>1117357</b>	<b>Knap, kompl.</b> <b>Switch, compl.</b> <b>Schalter, kompl.</b> <b>Interrupteur, compl.</b>		1	1	1	1
34	3805868	Omskifter Reverser Umschalter Inverseur	Y/Δ	1	1	1	1
36	4000287	Greb Knob Griff Bouton		1	1	1	1
37	6100100	Stift Pin Stift Goupille		1	1	1	1

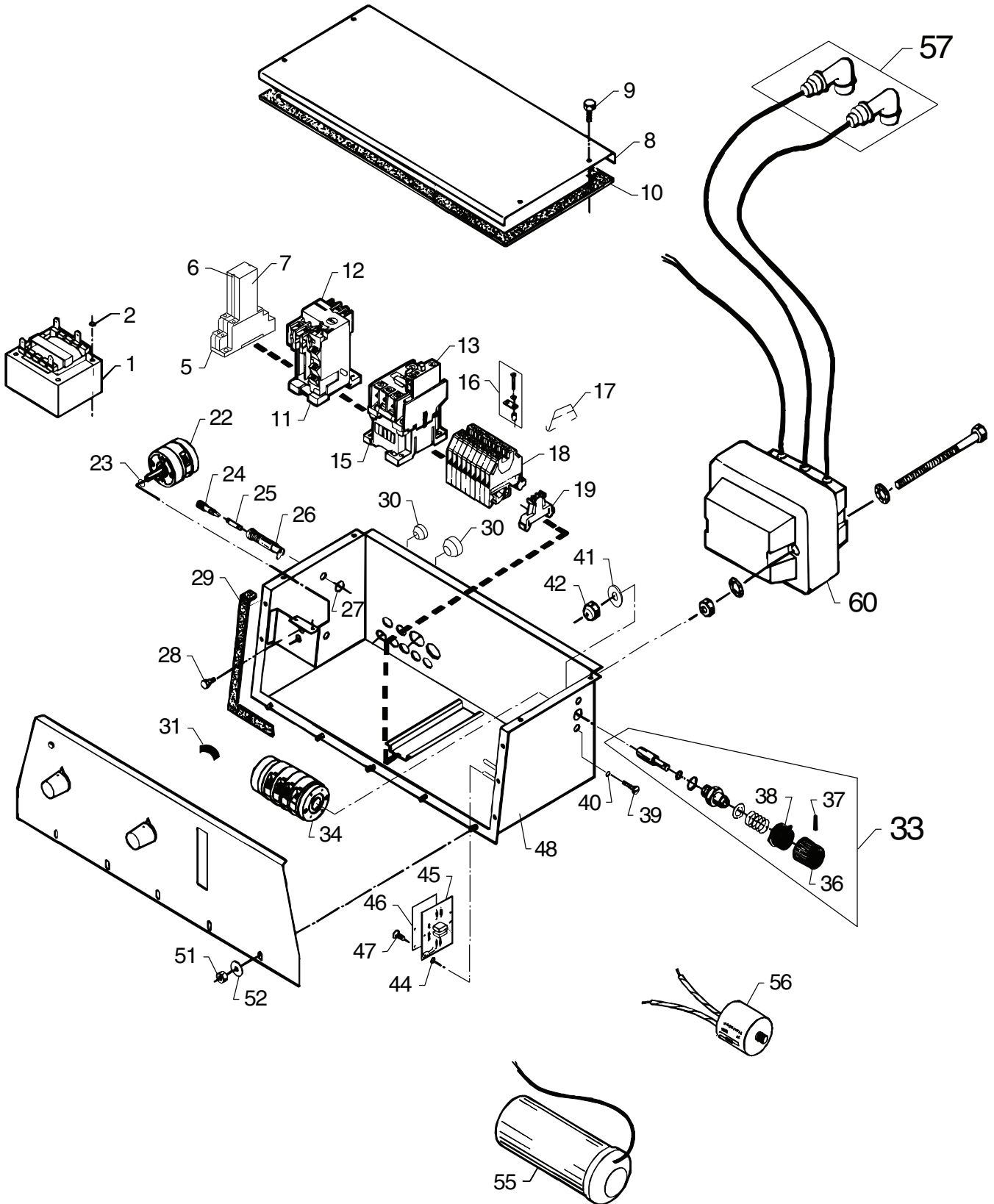

Pos. Ref.	Nr. No.	Betegnelse Bezeichnung	Designation Désignation	16A2V/VA	23A2V/VA	26A2V/VA	38A2V/VA
38	4000303	Viser Indicator Zeiger Indicateur		1	1	1	1
39	1803451	Skrue Screw Schraube Vis		1	1	1	1
40	3000387	O-ring O-ring O-Ring Joint torique		1	1	1	1
41	3000668	Skive Washer Scheibe Rondelle		2	2	2	2
42	1800457	Møtrik Nut Mutter Ecrou		2	2	2	2
44	6200750	Skive Washer Scheibe Rondelle		2	2	2	2
45	6201737	Print Circuit board 220-240V Print Circuit imprimé					
	6200752	Print Circuit board 380-440V Print Circuit imprimé					
-	6200815	Print Circuit board 440-500V Print Circuit imprimé					
46	6200751	Pap f. print Cardboard f. circuit board Pappe f. Print Carton p. circuit imprimé		1	1	1	1
47	1803139	Skrue Screw Schraube Vis		2	2	2	2
48	6201848	El-kasse Connection box Elektrogehäuse Boîtier électrique		1	1	1	1
-	6201889	El-kasse Connection box Elektrogehäuse Boîtier électrique	<b>B, E, I, N, CH</b>				1
51	1800697	Møtrik Nut Mutter Ecrou		12	12	12	12
52	1800887	Skive Washer Scheibe Rondelle		12	12	12	12
55	-	Kondensator Capacitor Kondensator Condensateur					
-	3807724	1x220V 60Hz	60 µf				
-	3804978	1x240V 50Hz, 1x220V 60Hz	66 µf				
-	3811916	1x115V 60Hz	145 µf				
-	3811924	1x208-230V 60Hz	72 µf				
56	3817202	Jorddrosselspole Radio interfer. suppressor Schutzleiterdrossel Conducteur de protection	<b>CH</b>				
<b>57</b>	1119302	<b>Rep.sæt, tændrørshætte</b> <b>Rep. kit, cover for sparking plug</b> <b>Rep. satz, Deckel für Zündkerzen</b> <b>Kit de rép., capuchon d'électrode</b>		1	1	1	1

Pos. Ref.	Nr. No.	Betegnelse Bezeichnung	Designation Désignation	16A2V/VA	23A2V/VA	26A2V/VA	38A2V/VA
60	-	Tændtransformer Ignition transformer Zündtransformator Transformateur d'allumage		1	1	1	1
-	3812567	3x415-440V	<b>AUS,GB,NZ,SGP,USA, Off-shore, U,M</b>				
-	3812559	3x380V	<b>A,AR,CL,D,DK,F,HK,IL,NL CH,PPE,S,SE,ET,GR</b>				
-	3812542	3x220-240V	<b>I,B,N,E,CN,ROK,SGP SJ,U,USA</b>				
-	3807401	1x208-230V	<b>CDN</b>				
-	3811882	1x110V	<b>CDN</b>				
65	-	Tilgangskabel Electric cable Anschlusskabel Câble électrique					
	6200861	H05VV-F 3G 1,5		x			x
	6200863	H05VV-F 4G 1,5	<b>B, I, E, N</b>				x
	6200866	H05VV-F 4G 2,5					x
	6200867	H07RN-F 4G 2,5					x
	6200870	AGW 10/3	<b>CDN</b>	x			x
	6200872	AGW 12/3	<b>CDN</b>	x			
	6200873	SVCT-F 4G 3,5	<b>J</b>			x	
	6180260	H07RN-F 4G 1.5	<b>3~</b>				x
	6180261	H07RN-F 3G 1.5	<b>1~</b>	x			
	6180268	H07RN-F 3G 4			x		
-	-	Stik Plug Stecker Prise		1	1	1	1
	3802493	CEE 5 pol. 380V/16A					
	3805793	1 pol.	<b>Eur.</b>				
	3802477	<b>S</b>					