

AUTO BOOSTER 5-20E



**Nilfisk
ALTO**
Why Compromise

Nilfisk-ALTO 2004.12.01

- Ⓓ Reservedele
- Ⓔ Spare parts
- Ⓓ Ersatzteile
- Ⓕ Pièces détachées

Ersatzteile auf www.gluesing.net

**Wap
KEW**
TECHNOLOGIES

Index

Chassis / Chassis / Châssis / Chassis.....	3-4
Electric parts / Elektrische Teile / Parties électriques / El-dele	5
Door w. coin acceptor/Tür m. Münzeinwurf/Porte avec Accepteur de pièces/jetons /Låge m. møntindkast.....	6
El-box / Klemmkasten / Boîtier cablage / El-kasse.....	7
Pump & Automatic pressure release	8
Water softening equipment.....	9
Heating tank / Erwärmungstank / Réservoir eau chaude / Opvarmningstank	10-11
Motor pump unit 5 / Motorpumpeneinheit 5 / Groupe moteur 5 / Motorpumpeenhed 5	12-17
Wash boom / Schwinkarm / Bras de lavage / Galge	18

Recommended spare parts

A-Parts:

Wearing parts. The recommended stock size is: [Number of machines x 1.2 x years] or min. 1.
These parts are typical: Water seals, valves, etc.

B-Parts:

Heavy used parts. The recommended stock size is: [Number of machines x 0.6 x years] or min. 1.
These parts are typical: By-pass valves, safety valves, seal kit, hoses, wobble disc bearings, etc.

C-Parts:

Important parts to run the machine. The recommended stock size is: [Number of machines x 0.1 x years] or min. 1.
These parts are typical: Electric parts, motors, transformers, relays, fuses, cylinder head, etc.

Empfohlene Ersatzteile

A-Teile:

Verschleissteile. Empfohlene Lagerstückzahl: [Anzahl der Maschinen x 1,2 x Jahre] oder min. 1.
Diese Teile sind typisch: Wasserdichtungen, Ventile, etc.

B-Teile:

Schwer beanspruchte Teile. Empfohlene Lagerstückzahl: [Anzahl der Maschinen x 0,6 x Jahre] oder min. 1.
Diese Teile sind typisch: Umlaufventile, Sicherheitsventile, Dichtungssätze, Schläuche, Taumelscheibenlager, etc.

C-Teile:

Zum Betrieb der Maschine wichtige Teile. Empfohlene Lagerstückzahl: [Anzahl der Maschinen x 0,1 x Jahre] oder min. 1.
Diese Teile sind typisch: Elektrische Teile, Motoren, Transformatoren, Relais, Sicherungen, Zylinderköpfe, etc.

Liste de pièces à stocker

Pièces A:

Pièces d'usure. Le stock conseillé est: [nombre de machines x 1,2 x années] avec un minimum de 1.
Classiquement, ces pièces sont: les joints d'eau, les clapets, etc.

Pièces B:

Pièces fortement sollicitées. Le stock conseillé est: [nombre de machines x 0,6 x années] avec un minimum de 1.
Classiquement, ces pièces sont: la vanne by-pass, les kits de joints, les flexibles, les roulements de disque oblique, etc.

Pièces C:

Pièces nécessaires au fonctionnement. Le stock conseillé est: [nombre de machines x 0,1 x années] avec un minimum de 1.
Classiquement, ces pièces sont: composants électriques, moteurs, transformateurs, relais, fusibles, culasses, etc.

Anbefalede reservedele

A-Parts:

Sliddele. Anbefalet lagerstørrelse: [Antal maskiner x 1,2 x år] eller min. 1.
Disse dele er typisk: Vandmanchetter, ventiler m.v.

B-Parts:

Hårdt belastede dele. Anbefalet lagerstørrelse: [Antal maskiner x 0,6 x år] eller min. 1.
Disse dele er typisk: By-pass ventiler, sikkerhedsventiler, manchet kit, slanger, skrånede lejer m.v.

C-Parts:

Vigtige dele for at maskinen kører. Anbefalet lagerstørrelse: [Antal maskiner x 0,1 x år] eller min. 1.
Disse dele er typisk: Elektriske dele, motorer, transformere, relæer, sikringer, topstykke m.v..

Chassis / Chassis / Châssis / Chassis

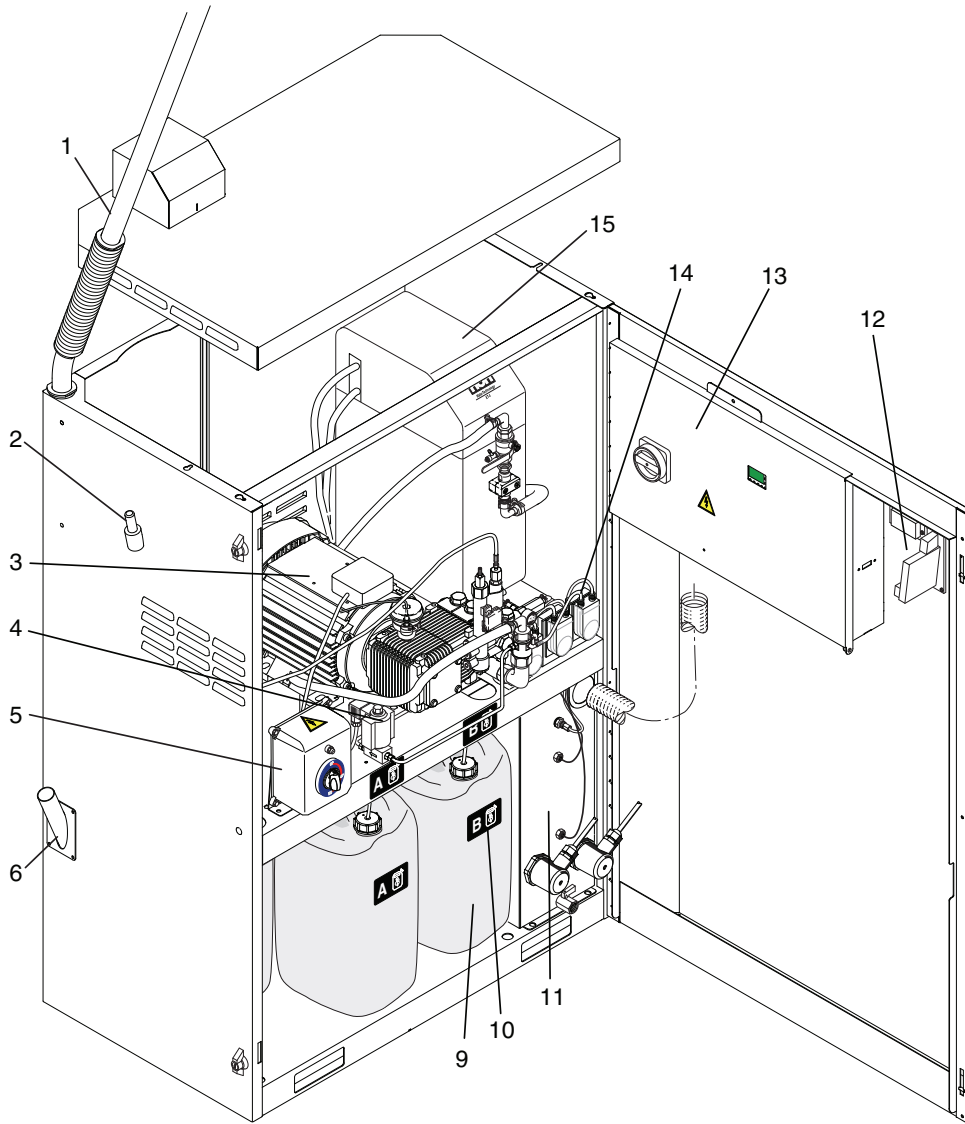

Pos.	No.	Description	Bezeichnung	Désignation	Betegnelse	Comment Bemerkung Remarque Bemærkning	Rec. Part	5-20E	7-20E
1	-	Wash boom, compl.	Schwinkarm, kompl.	Bras de lavage complet	Galge, kompl.	Page 26	1	1	
2	107313069	Brush rack	Bürstenhalter	Porte-brosse	Børsteholder		1	1	
3	-	Motor pump unit	Motorpumpeneinheit	Groupe moto-pompe	Motorpumpenhed	Page 12 -17 &18-25	1		
4	-	Pressure relief	Druckentlastung	Décompression	Trykaflastning	Page 8	1	1	
5	-	El-box	Klemmkasten	Boîtier électrique	El-box, kompl.	Page 7	1	1	
6	107313067	Support for spray lance	Halter für Sprührohr	Support de lance	Dyserørsholder		1	1	
9	2005718	Can 25L	Kanister	Bidon 25 litres	Dunk 25L		2	2	
10	107319150	Label "A"	Aufkleber	Autocollant	Label "A"		2	2	
10	107319151	Label "B"	Aufkleber	Autocollant	Label "B"		2	2	
10	107319152	Label "C"	Aufkleber	Autocollant	Label "C"		3	3	
11	-	Heating tank	Erwärmungstank	Réservoir eau chaude	Opvarmningsdtank	Page 10, 11	3	3	
12	-	Coin acceptor unit	Münzeinwurfteinheit	Accepteur de pièces/jetons	Montindkastehed	Page 6	1	1	
13	-	Electric parts	Elektrische Teile	Armoire électrique	El-dele	Page 5	1	1	
14	107318047	Detergent pump	Zusatzmittelpumpe	Pompe détergent	Kempumpe		1	1	
14A	102406658	Repair hose Ø6 for detergent pump	Reparaturschlauch Ø6 für Zusatzmittelpumpe	Tuyau Ø6 réparation pompe détergent	Reparationssslange Ø6 for kempumpe		x	x	
15	-	Water softening equipment	Wasserenthärtungsanlage	Installation Adoucisseur d'eau	Vandblødgøringsanlæg	Page 9	1	1	

Chassis /overview

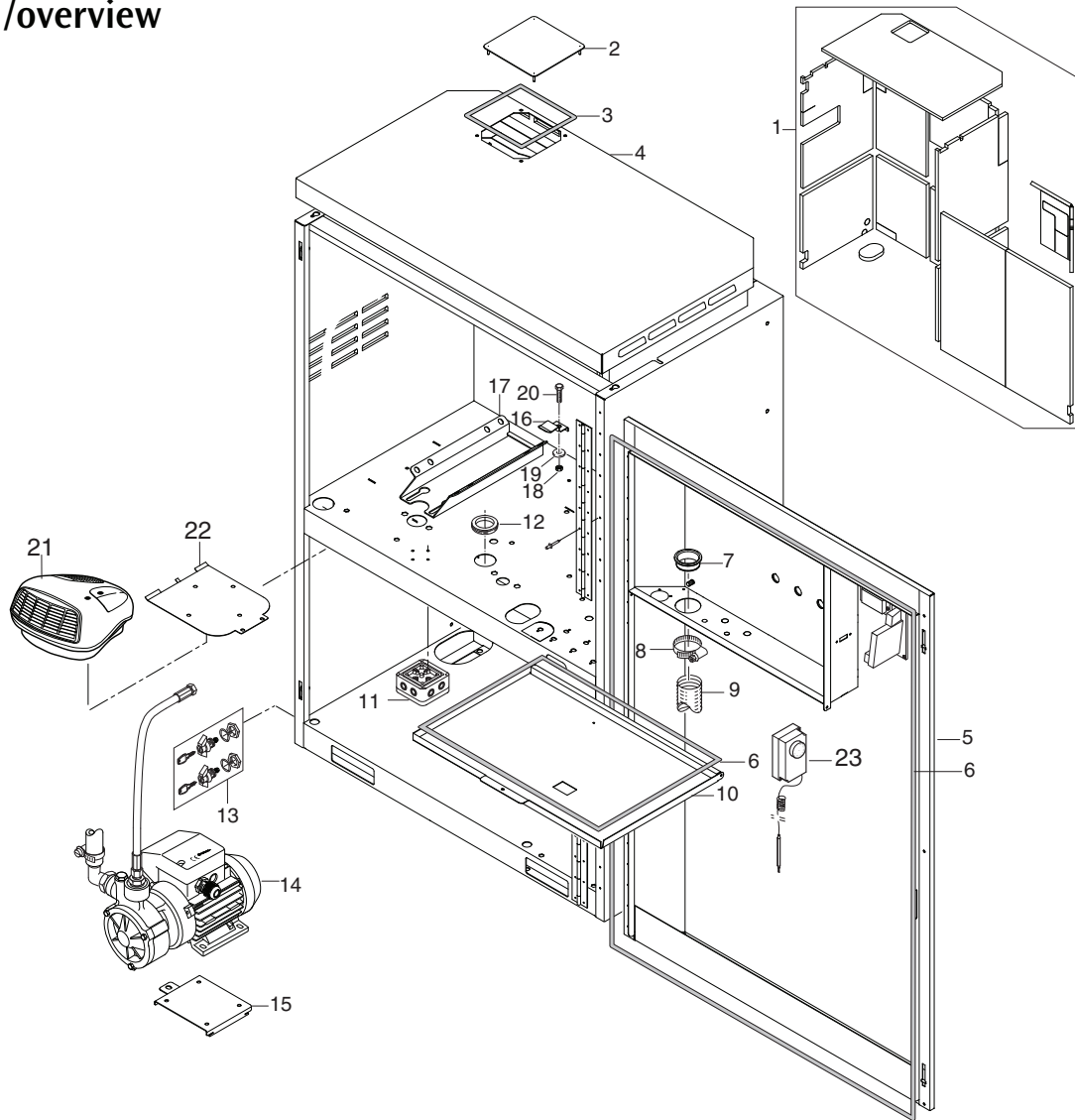

Pos.	No.	Description	Bezeichnung	Désignation	Betegnelse	Comment Bemerkung Bemærkning	Rec. Part	5-20E	7-20E
1	107318029	Isolation	Isolierung	Isolation	Isolering			1	1
2	107313073	Cover	Deckel	Couvercle	Dæksel			1	1
⌘ 3	6250	Self-adhesive band (0,7m)	Selbstklebendes Band	Ruban adhésif	Selvklebende bånd			1	1
4	107313231	Cabinet top	Oberteil des Gehäuses	Dessus du capôt	Kabinetttop			1	1
5	107313213	Cabinet door	Tür	Porte	Låge/dør			1	1
⌘ 6	5218754	Rubber profil D (5,4m)	D-Profil, Gummi	Profil en D caoutchouc	Gummi profil D			1	1
7	107313243	Junction-piece	Verbinder	Connexion	Overgang f. flexslange			1	1
8	1806637	Hose clip	Schlauchselle	Collier de serrage	Spændebånd			1	1
⌘ 9	5226305	Flexible hose (0,7m)	Flexschlauch	Tuyau flexible	Flexslange			1	1
10	107313216	Cover for electric parts	Deckel f. elektrische Teile	Couvercle	Låge for eldele			1	1
11	103822013	Distributor box	Verteilerdose	Bornier	Forgreningsdåse			1	1
12	103004331	Sleeve	Manchette	Manchette	Manchet			1	1
13	101814750	2x(Lock and key)	2x(Schloss und Schlüssel)	2x(Serrure & clef)	2x(Lås og nøgle)			1	1
14	-	Pump	Pumpe	Pompe	Pumpe, kompl.	Page 8		1	1
15	107313265	Pump support	Pumpenbeschlag	Support pour pompe	Pumpebeslag			1	1
16	107313021	Hook	Federschloss	Patte de fixation	Fjederclips				1
17	107313022	Motor pump support	Motorpumpenbeschlag	Support moteur - pompe	Motorpumpebeslag				1
18	1802966	Nut M10	Mutter	Ecrou M10	Møtrik M10				3
19	1801968	Safety washer	Sicherungsscheibe	Rondelle de sécurité	Sikringsskive				3
20	1810209	Screw M10x12	Schraube	Vis M10x12	Skrue M10x12				3
21	107316095	Fan heater	Heizlüfter	Radiateur soufflant	Varmevifte			1	1
22	107313076	Support	Halter	Support	Beslag			1	1
23	103822056	Thermostat	Thermostat	Thermostat	Termostat			1	1
-	107319142	Instruction manual	Betriebsanleitung	Manuel utilisateur	Instruktionsbog	DA, NO, SV, FI		1	1
-	107319143	Instruction manual	Betriebsanleitung	Manuel utilisateur	Instruktionsbog	Eur.		1	1

Niffisk-ALTO - AUTO BOOSTER - Jan. 2005

⌘ **ATTENTION!** - Lengths in metres - Please indicate required length when ordering!
 ⌘ **ACHTUNG!** - Meterware - Bitte bei Bestellung gewünschte Länge angeben!

⌘ **ATTENTION!** - Longueurs par mètre - Préciser la longueur à la commande!
 ⌘ **BEMÆRK!** - Meterware - Vær venlig at oplyse længde ved bestilling!

Electric parts / Elektrische Teile / Parties électriques / El-dele

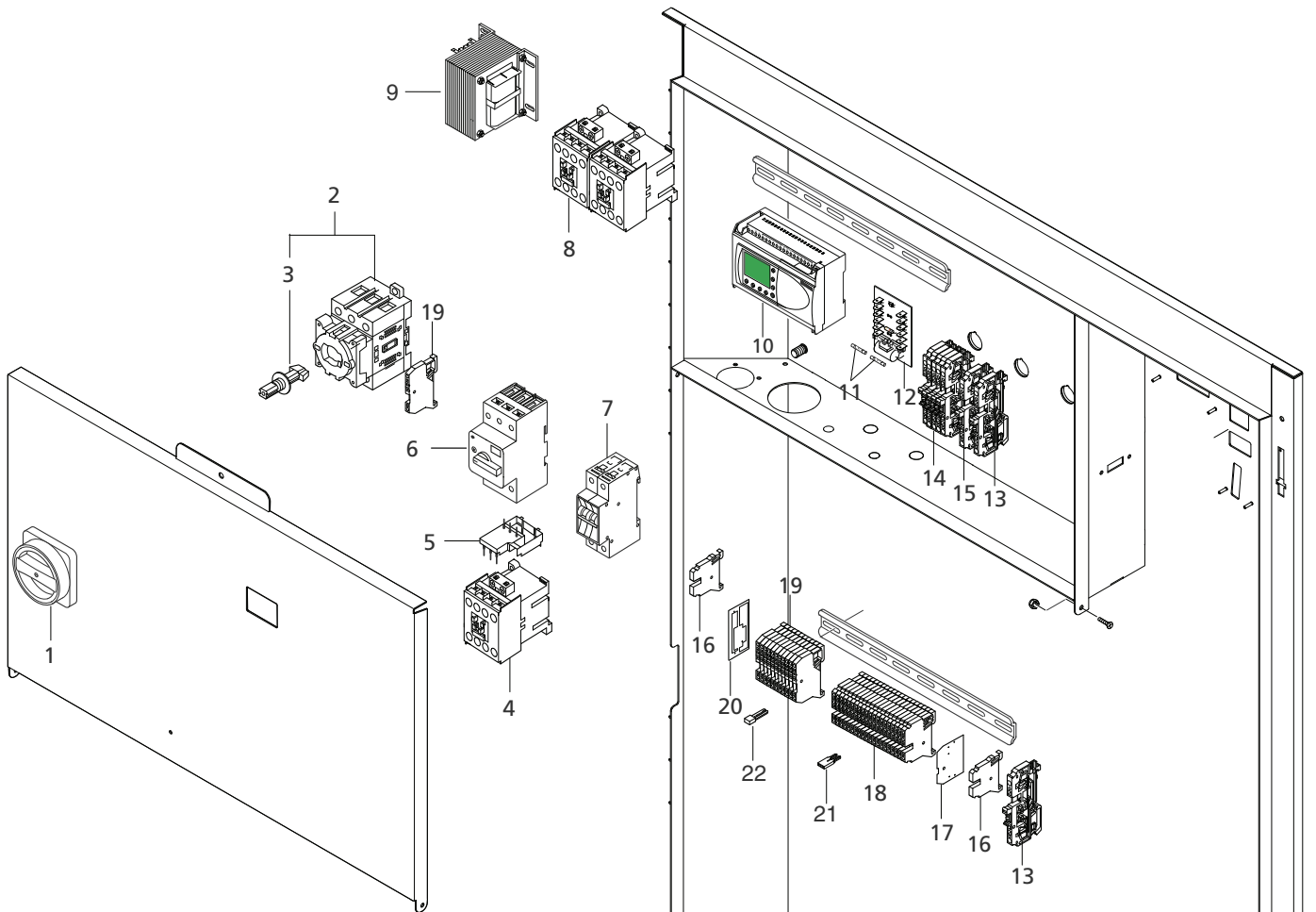

Pos.	No.	Description	Bezeichnung	Désignation	Betegnelse	Comment Bemerkung Remarque Bemærkning	Rec. Part	5-20D	5-20E	7-20E
1	3830121	Control knob	Bedienteil	Bouton interrupteur principal	Betjeningsgreb			1	1	1
2	103821919	Main switch	Hauptschalter	Interrupteur principal	Hovedafbryder	25A		1		
2	103821908	Main switch	Hauptschalter	Interrupteur principal	Hovedafbryder	63A			1	1
3	103821960	Axle	Achse	Axe	Aksel			1	1	1
4	301000599	Contacteur 100-C16KJ01	Schütz	Contacteur 24V	Kontaktor	400-440V	C	1	1	1
4	3821739	Contacteur 100-C23KJ10	Schütz	Contacteur 24V	Kontaktor	400-440V	C		1	1
4	103822037	Contacteur 100-C23KJ01	Schütz	Contacteur 230V	Kontaktor	3x230V		(1)		
5	103821899	Connection modul	Verbindungsmodul	Module assemble	Samlemodul			1	2	2
6	103821898	Overcurrent release 10-16A	Überstromschutz	Protection surintensité	Overstrømsafbryder	400-440V		1	1	1
6	103821909	Overcurrent release 14-20A	Überstromschutz	Protection surintensité	Overstrømsafbryder	400-440V			1	1
6	103821903	Overcurrent release 18-25A	Überstromschutz	Protection surintensité	Overstrømsafbryder	3x230V		(1)		
7	103822011	Safety device	Automatischesicherung	Sécurité automatique	Automatsikring	400-440V		1	1	1
7	103822012	Safety device	Automatischesicherung	Sécurité automatique	Automatsikring	3x230V		(1)		
8	3821732	Contacteur AB 16A, 24V	Schütz	Contacteur AB 16A 24V	Kontaktor	3x230V- 4 Stk/pc	C	2	1	1
9	103821847	Control transformer 230V 24/19V	Steuerungstransformator	Transformateur commande 230V	Sikkerhedstraformer		C	1	1	1
10	106426090	PLC	PLC	Automate programmable	PLC			1		
10	106426091	PLC	PLC	Automate programmable	PLC				1	1
11	3812385	Fuse D5x20	Sicherung	Fusible 6,3A Ø5x20	Sikring		C	2	2	2
12	106420051	Circuit board	Steuerelektronik	Circuit imprimé	Print			1	1	1
13	103822034	Interrupter terminal	Interrupterklemme	Borne	Afbryderklemme 280-868	S6 - S11		2	2	2
14	103822031	Interrupter terminal	Interrupterklemme	Borne	Afbryderklemme	S1.....S5		5	5	5
15	103822035	Interrupter terminal	Interrupterklemme	Borne	Afbryderklemme 280-879	S12		1	1	1
16	103821922	End stop	Abschlußplatte	Support de bornier	Endestop			3	3	3
17	103821921	End plate	Endplatte	Plaque	Endeplade			1	1	1
18	103821920	Wire terminal	Reihenleuchte	Bornier	Rækkeleuchte			29	29	29
19	103821967	Wire terminal	Reihenleuchte	Bornier	Rækkeleuchte	3x230V- 22 Stk/pc		8	8	8
20	103821968	End plate	Endplatte	Plaque	Endeplade			1	1	1
21	103821923	Jumper 2-pol.	Einleuchtebrücke 2-fach	Cavalier 2 pôles	2-pol laske			1	1	1
22	103821969	Jumper 2-pol.	Einleuchtebrücke 2-fach	Cavalier 2 pôles	2-pol laske			1	1	1

Door with coin acceptor / Tür mit Münzeinwurf /
Porte avec Accepteur de pièces/jetons / Låge med møntindkast

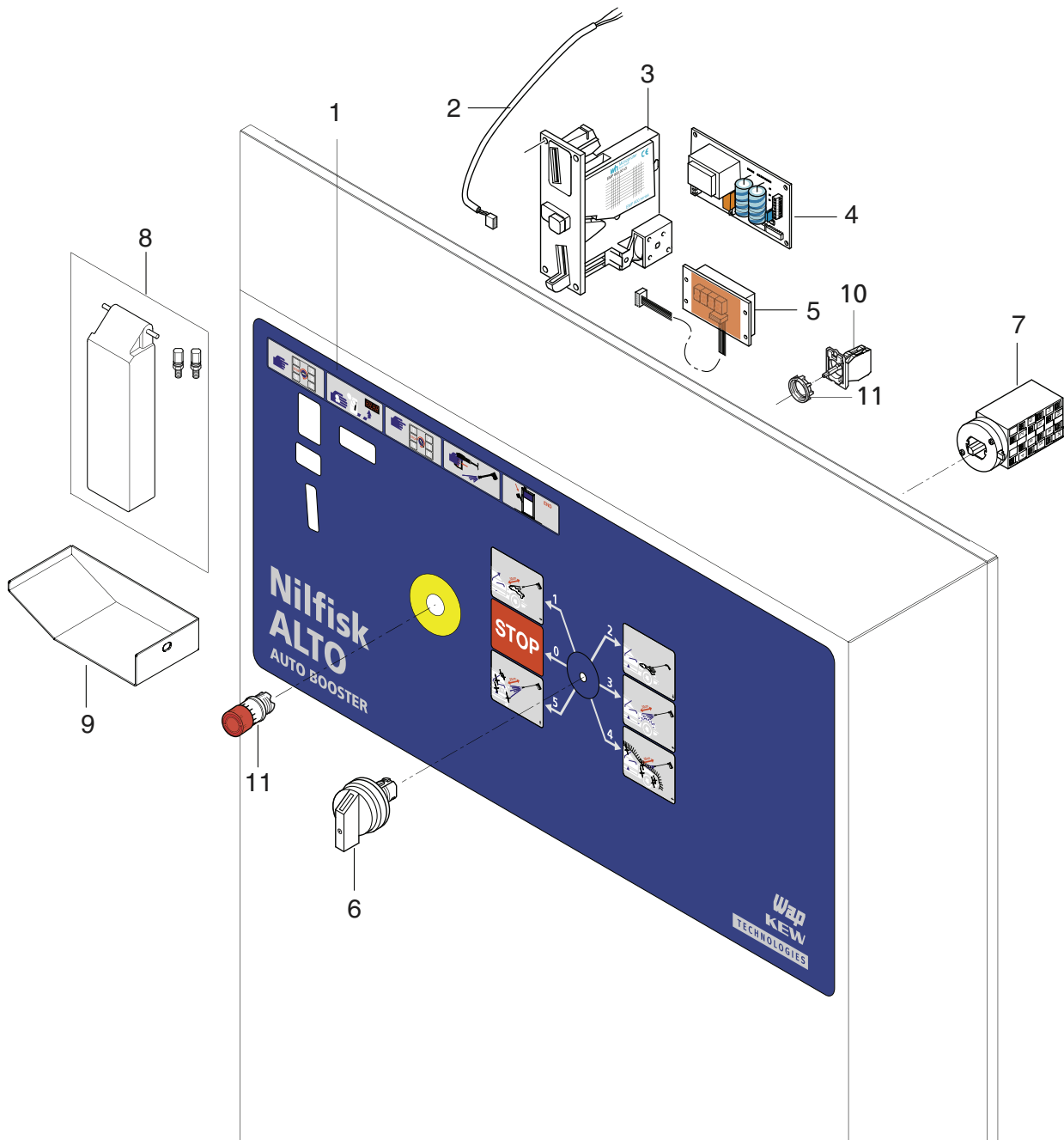

Pos.	No.	Description	Bezeichnung	Désignation	Betegnelse	Comment Bemerkung Remarque Bemærkning	Rec. Part	5-20D	5-20E12	7-20E6
1	107319220	Front label	Aufkleber	Autocollant	Front label			1	1	1
2	107318046	Cable	Kabel	Câble	Kabel			1	1	1
3	107318035	Coin acceptor £, €, CHF	Münzeinwurf	Accepteur jetons/pièces	Møntindkast			1	1	1
3	107318036	Coin acceptor NOK, DKK, SEK	Münzeinwurf	Accepteur jetons/pièces	Møntindkast			1	1	1
4	107318040	Timer	Timer	Timer	Timer			1	1	1
5	107318045	Display	Display	Display (écran)	Display			1	1	1
6	909100204	Adjusting knob	Drehschalter	Bouton rotatif	Drejeknap			1	1	1
7	103822019	Dial	Programmwähler	Sélecteur	Programvælger			1	1	1
8	103822028	Cover for coin acceptor	Deckel für Münzeinwurf	Couvercle pour appareil à encaissement	Låge for møntindkast			1	1	1
9	107313071	Coin collector	Münzauffang	Collecteur	Møntopsamler			1	1	1
10	103822030	Contact element	Kontakt	Contact	Kontaktelement	OPTION				
11	103822029	Emergency switch	Notschalter	Arrêt d'urgence	Nødstop	OPTION				

El-box / Klemmkasten / Boîtier cablage / El-kasse

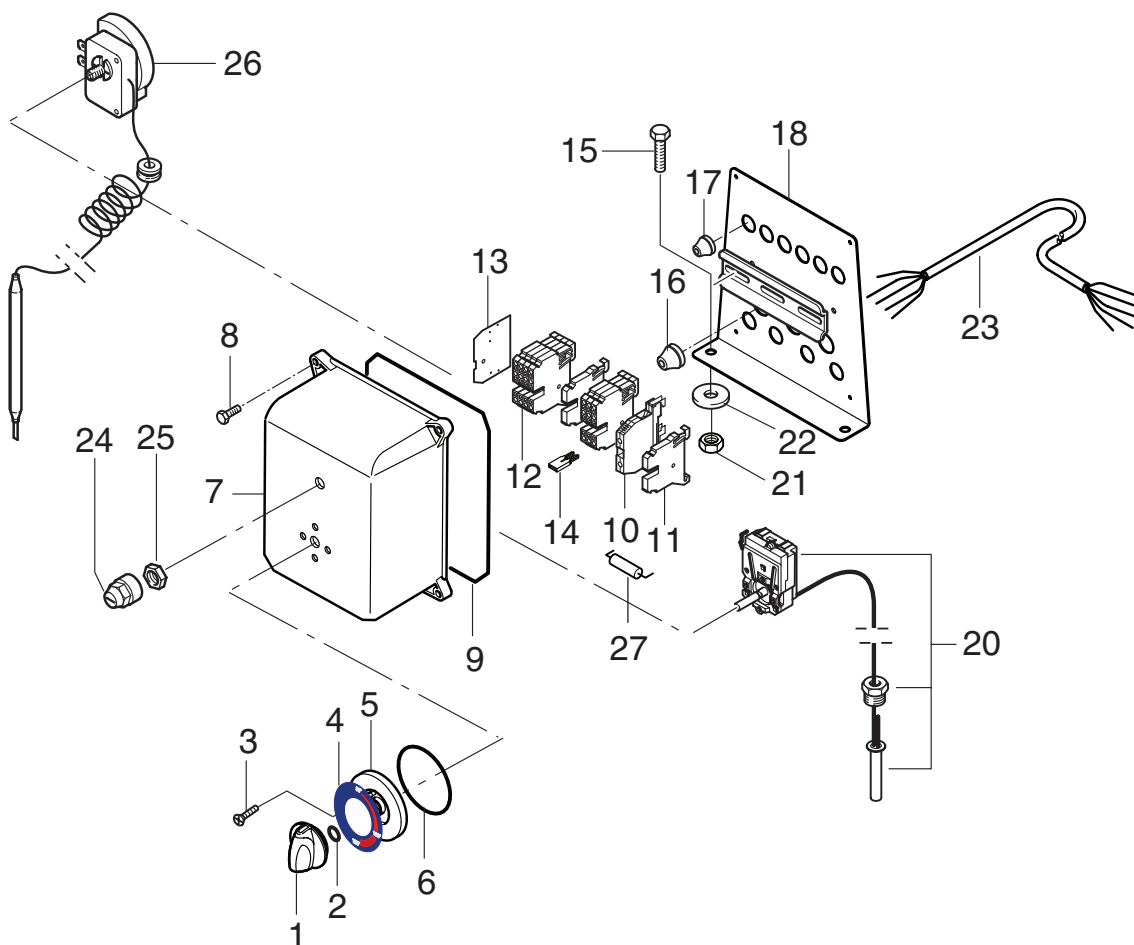

Pos.	No.	Description	Bezeichnung	Désignation	Betegnelse	Comment Bemerkung Remarque Bemærkning	Rec. Part	5-20D	5-20E12	7-20E6
1	909100204	Adjusting knob Ø6x5	Drehschalter	Bouton tournant Ø6x5	Drejeknap			1	1	1
2	9868	O-ring 10,0x2,5	O-ring	Joint torique 10,0x2,5	O-ring			1	1	1
3	107319139	Label	Aufkleber	Autocollant	Label			1	1	1
4	1801612	Screw M4x6	Schraube	Vis	Skrue			4	4	4
5	107313045	Socket, compl.	Socket, kompl.	Embase complète	Sokkel, kompl.			1	1	1
6	3001443	O-ring 60x2.62	O-ring	Joint torique	O-ring			1	1	1
7	107316091	Cover for el-box	Deckel	Capôt	Låg	5-20D		1		
7	107316093	Cover for el-box	Deckel	Capôt	Låg	5-20E, 7-20E			1	1
8	1804822	Screw M4x16	Schraube	Vis M4x16	Skrue			4	4	4
9	6180141	Gasket	Dichtung	Joint	Pakning			1	1	1
10	3817483	Wire terminal, earth	Reihen клемме, Erdung	Bornier, terre	Klemmerække, jord			2	2	2
11	103821922	End stop	Abschlußplatte	Support de bornier	Endestop			1	1	1
12	103821920	Wire terminal	Reihen клемме	Bornier	Række клемме			13	13	13
13	103821921	End plate	Endplatte	Plaque	Endeplade			1	1	1
14	103821923	Jumper 2-pol.	Einlegebrücke 2-fach	Cavalier 2 pôles	2-pol laske			1	1	1
15	1810209	Screw M10x12	Schraube	Vis M10x12	Skrue M10x12			2	2	2
16	3803772	Cable grommet 7-10C	Stopfbuchse	Presse-étoupe 7-10C	Pakdåse	TET 7-10C		6	6	6
17	3803764	Cable grommet 5-7C	Stopfbuchse	Presse-étoupe 5-7C	Pakdåse	TET 5-7C		7	7	7
18	107313234	Plate	Platte	Plaque	Plade			1	1	1
20	103822027	Thermostat 20-60	Thermostat	Thermostat	Termostat			1	1	1
21	1802966	Nut M10	Mutter	Ecrou M10	Møtrik M10			2	2	2
22	1801968	Safety washer	Sicherungsscheibe	Rondelle de sécurité	Sikringskive			2	2	2
23	3830045	Mains cable	Netzleitung 5G2,5	Câble	Tilgangskabel 5G2,5			1	1	1
24	34970	Cap	Kappe	Manteau	Hætte	5-20E, 7-20E			1	1
25	47313	Nut	Mutter	Ecrou	Møtrik	5-20E, 7-20E			1	1
26	47358	Safety thermostat	Sicherheitstemp. Begrenzer	Thermostat de sécurité	Sikkerhedstermostat	5-20E, 7-20E			1	1
27	103822009	Resistance	Widerstand	Resistance	Modstand 27K			1		

Pump & Automatic pressure release

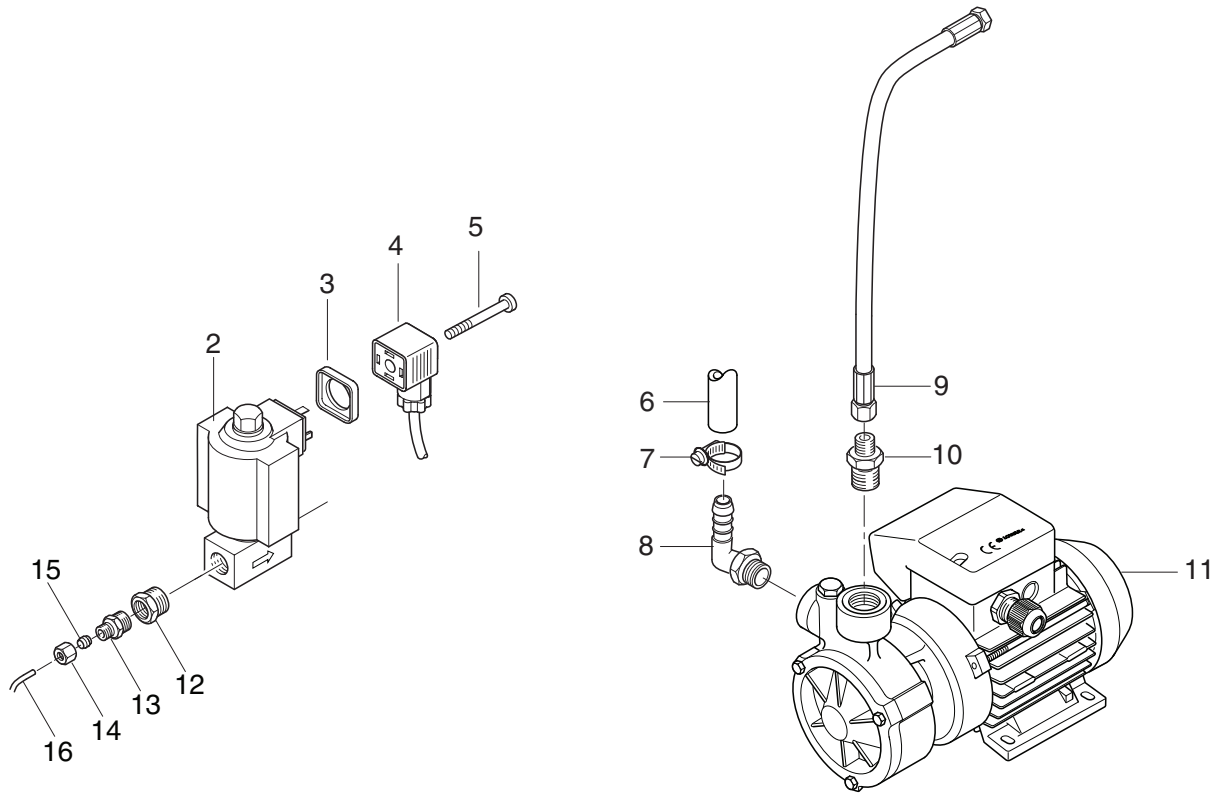

Pos.	No.	Description	Bezeichnung	Désignation	Betegnelse	Comment Bemerkung Bemærkning	Rec. Part	5-20D	5-/7-20E
2	53730	Solenoid valve 24VDC	Magnetventil	Vanne magnétique 24VDC	Magnetventil			1	
2	103822026	Solenoid valve 230V 50Hz	Magnetventil	Vanne magnétique 230V	Magnetventil				1
3	17767	Packing	Dichtung	Joint	Pakning			1	1
4	46877	Coupler	Stecker Magnetventil	Raccord électrique	Stik f. magnetventil			1	
4	34865	Coupler	Stecker Magnetventil	Raccord électrique	Stik f. magnetventil				1
5	17768	Screw M3x25	Schraube	Vis M3x25	Skruue			1	1
⌘	6	5206230	Hose	Schlauch	Tuyau	Slange		1	1
7	1810191	Hose clip	Schlauchschele	Collier de serrage	Spændebånd			1	1
8	101609381	Hose socket, elbow	Winkelschlauchstutzen	Raccord coude	Slangestudsvinkel			1	1
9	101405741	High pressure hose	Hochdruckschlauch	Tuyau haute pression	Højtryksslange			1	1
10	1600998	Threaded connection	Verschraubung	Raccord fileté	Forskruning			1	1
11	103822025	Pump	Pumpen	Pompe	Pumpe			1	1
12	1601046	Threaded connection	Verschraubung	Raccord fileté	Forskruning			2	2
13	1603422	Threaded connection	Verschraubung	Raccord fileté	Forskruning			2	2
14	1603448	Cutting ring Ø4	Schneidring	Anneau Ø4	Skæring			2	2
15	1603430	Union nut Ø4	Überwurfmutter	Ecrou Ø4	Omløber			2	2
⌘	16	5203823	Copper tube	Kupferrohr	Tube cuivre Ø4	Kobberrør		1	1

Nifisk-ALTO - AUTO BOOSTER - Dec. 2004

⌘ **ATTENTION!** - Lengths in metres - Please indicate required length when ordering!
 ⌘ **ACHTUNG!** - Meterware - Bitte bei Bestellung gewünschte Länge angeben!

⌘ **ATTENTION!** - Longueurs par mètre - Préciser la longueur à la commande!
 ⌘ **BEMÆRK!** - Metervare - Vær venlig at oplyse længde ved bestilling!

Ersatzteile auf www.gluesing.net

Water softening equipment

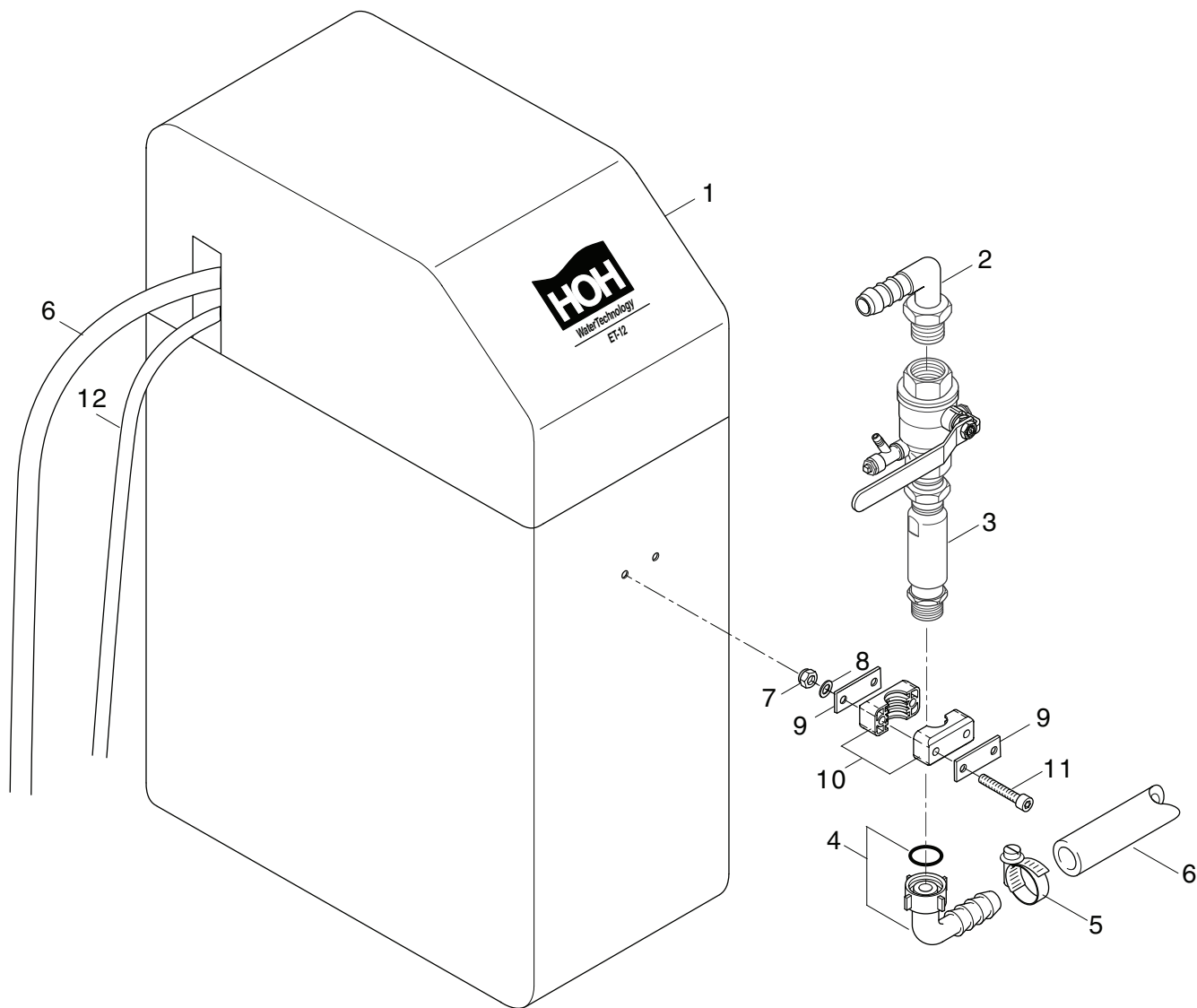

Pos.	No.	Description	Bezeichnung	Désignation	Betegnelse	Comment Bemerkung Remarque Bemærkning	Rec. Part	5-20D	5-20E	7-20E
1	104601166	Water softening unit	Wasserenthärtungseinheit	Adoucisseur d'eau	Blødgøringsenhed	OPTION		1	1	1
2	101609353	Hose socket, elbow	Schlauchstutzen	Raccord coudé	Slangestudsvinkel		C	1	1	1
3	103403271	Vacuum control valve	Vakuumentil	Vanne	Vakuumentil			1	1	1
4	1603036	Hose socket, elbow	Schlauchstutzen	Raccord coude	Slangestudsvinkel			1	1	1
5	1802107	Hose clip	Schelle	Collier de serrage	Spændebånd			1	1	1
⌘ 6	5206230	Hose	Schlauch	Tuyau	Slange			1	1	1
7	1805399	Nut M6	Mutter	Ecrou M6	Møtrik			2	2	2
8	1803378	Washer M6	Scheibe	Rondelle M6	Skive			2	2	2
9	7302021	Clamping plate	Spannplatte	Plaque de fixation	Spændeplade			2	2	2
10	1609297	Bracket for pipe	Rohhalter	Support pour tube	Rørholder			1	1	1
11	101814694	Screw M6x55	Schraube	Vis M6x55	Skruer			2	2	2
⌘ 12	5206461	Hose	Schlauch	Tuyau	Slange			1	1	1

Heating tank / Erwärmungstank / Réservoir eau chaude / Opvarmningstank

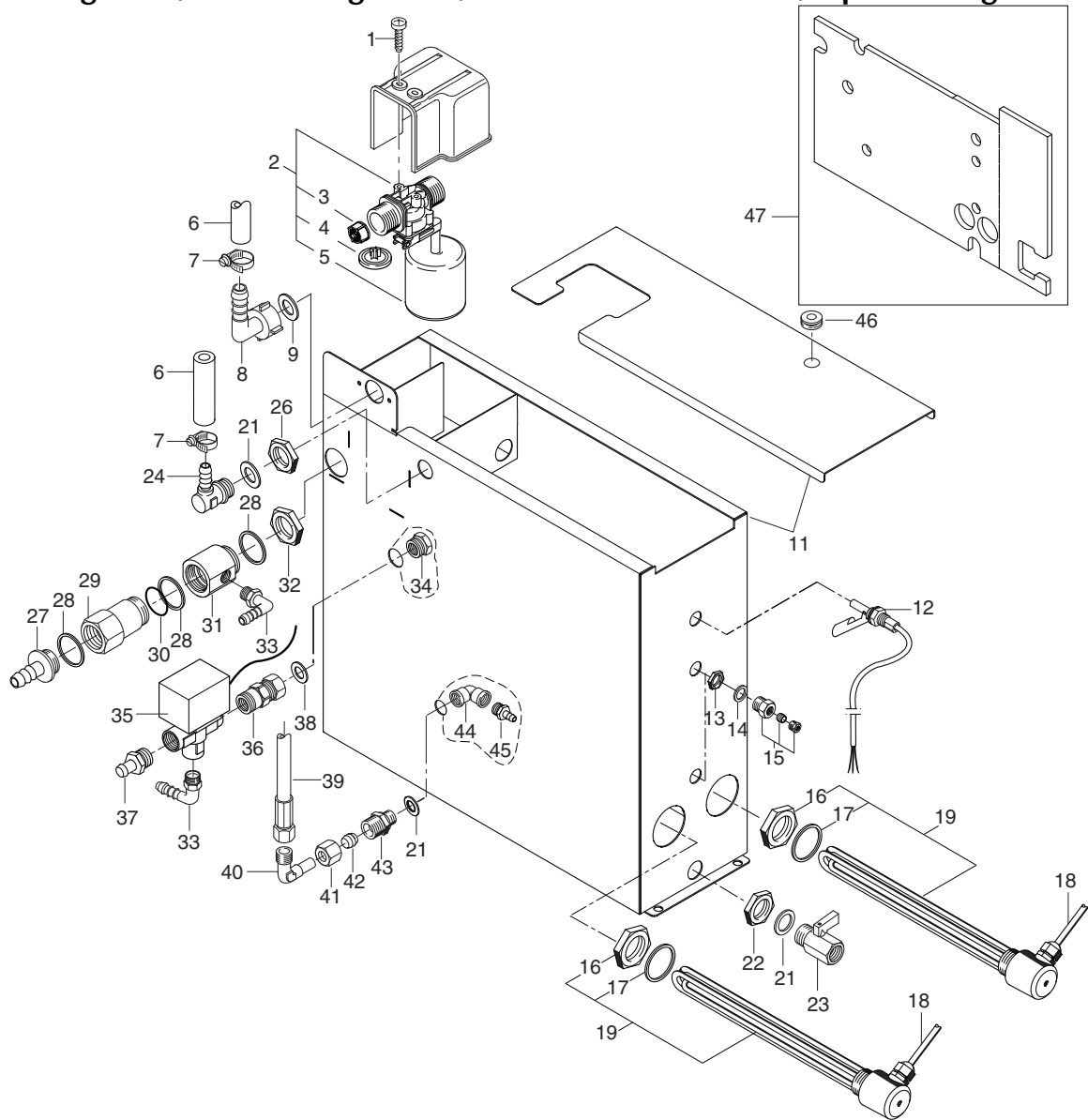

Pos.	No.	Description	Bezeichnung	Désignation	Betegnelse	Comment Bemerkung Remarque Bemærkning	Rec. Part	5-20E	7-20E
1	16860	Screw	Schraube	Vis	Skrue			2	2
2	63349	Float valve, compl.	Schwimmerventil, kompl.	Vanne flotteur complète	Svømmerventil, kompl.		C	1	1
3	34225	Stainer	Schmutzfilter	Filtre	Filter			1	1
4	62878	Rubber diaphragm	Gummimembrane	Membrane caoutchouc	Membran			1	1
5	62877	Float	Schwimmer	Flotteur	Svømmer			1	1
⊠ 6	5206230	Hose	Schlauch	Tuyau	Slange			1	1
7	1810191	Hose clip	Schlauchschelle	Collier de serrage	Spændebånd			1	1
8	5613	Hose socket	Schlauchtülle G1/2"	Raccord tuyau	Slangestuds			2	2
9	15587	Gasket	Dichtung	Joint	Paking			1	1
11	107315042	Water tank with cover	Wassertank mit Abdeckung	Reservoir d'eau avec couvercle	Vandtank med låg			1	1
12	3817582	Level switch	Niveauekontakt	Contact de niveau	Niveauføler		C	1	1
13	1399	Nut 3/8"x3,5	Mutter	Ecrou 3/8"x3,5	Møtrik			1	1
14	1801075	Gasket	Dichtung	Joint	Pakning			1	1
15	9287	Threaded connection	Verschraubung	Raccord	Forskruing			1	1
16	7932	Gasket	Dichtung	Joint	Pakning			2	2
17	103821817	Nut f. heating element	Mutter	Ecrou	Møtrik			2	2
18	3830153	Cable	Leitung	Câble	Lednig			2	2
19	22297	Heating element	Heizkörper	Résistance électrique	Varmelegme		C	2	2
21	3449	Gasket	Dichtung	Joint	Pakning		C	5	5
22	101609356	Nut 1/2"	Mutter	Ecrou	Møtrik			1	1
23	3400819	Drain cock	Ablasshahn	Robinet (vidange)	Aftapningshane			1	1

Nifisk-ALTO - AUTO BOOSTER - Dec. 2004

⊠ ATTENTION! - Lengths in metres - Please indicate required length when ordering!
 ⊠ ACHTUNG! - Meterware - Bitte bei Bestellung gewünschte Länge angeben!

⊠ ATTENTION! - Longueurs par mètre - Préciser la longueur à la commande!
 ⊠ BEMÆRK! - Meterware - Vær venlig at oplyse længde ved bestilling!

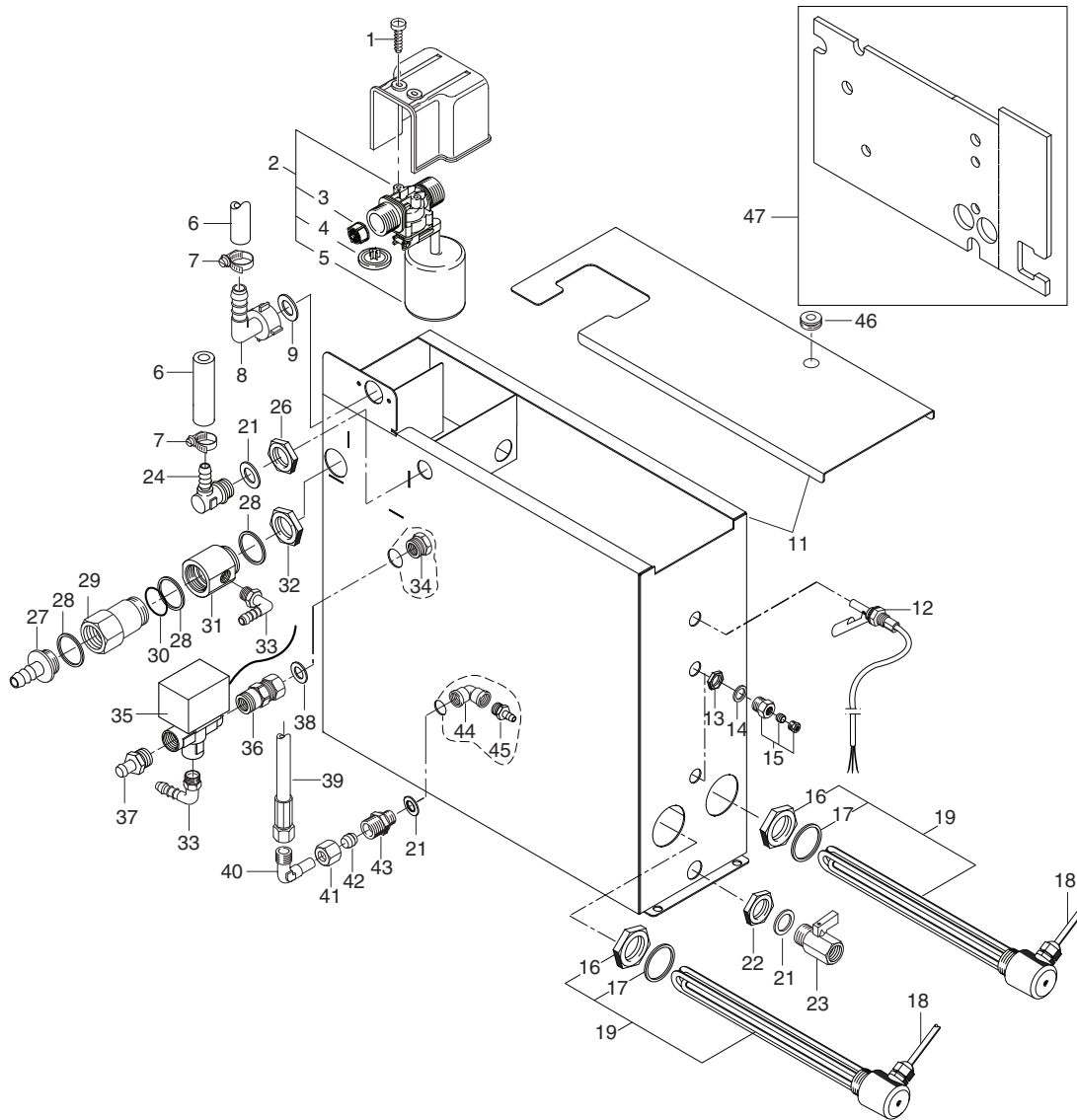

Pos.	No.	Description	Bezeichnung	Désignation	Betegnelse	Comment Bemerkung Remarque Bemærkning	Rec. Part		
							5-20E	7-20E	
24	3448	Hose socket DN13	Schlauchstutzen	Raccord DN13	Slangestuds DN13		1	1	
26	101609356	Nut	Mutter	Ecrou	Møtrik 1/2"		1	1	
27	6400403	Hose socket	Schlauchstutzen	Raccord	Slangestuds		1	1	
28	103004340	Fiber gasket	Dichtung	Joint	Fiberpakning		3	3	
29	6400402	Non-return valve	Rückschlagventil	Clapet anti-retour	Kontraventil		1	1	
30	3001401	O-Ring	O-Ring	Joint torique 28x3	O-ring 28x3		1	1	
31	107315044	Junction-piece	Verbinder	Connexion	Overgang f. kontraventil		1	1	
32	6304263	Lock nut	Gegenmutter	Contre-écrou	Kontramøtrik 1"RG		1	1	
33	101609355	Nipple, coude	Winkelschlauchnippel	Mamelon, coude	Vinkelslangenippel		2	2	
34	101609385	Reducing bushing 3/4x3/8	Reduzierstück	Réduction mâle-femelle	Nippelmuffe 3/4x3/8		1	1	
35	103822036	Three-way valve	Dreiweg-Ventil	Vanne à trois voies	Treveysventil		1	1	
36	101609382	Radiator fitting	Heizkoerperverschraubung	Raccord	Radiatorforskruning		1	1	
37	1609319	Nipple	Nippel	Mamelon	Slangenippel		1	1	
38	2377	Sealing washer	Dichtungsscheibe	Rondelle d'étanchéité	Tætningssskive		1	1	
39	101405741	High pressure hose 150°	Hochdruckschlauch	Tuyau haute pression	Højtryksslange 150°C		1	1	
40	1601012	Threaded connection, elbow	Winkerverschraubung	Raccord coudé	Vinkelforskruning		1	1	
41	1600451	Union nut	Überwurfmutter	Ecrou	Omløber		1	1	
42	1600469	Cutting ring	Schneidring	Anneau	Skærering		1	1	
43	1600998	Threaded connection	Verschraubung	Raccord	Ligeforskruning		1	1	
44	20680	Elbow	Winkel	Coude	Vinkel		1	1	
45	101609359	Hose socket	Schlauchstutzen	Raccord	Slangestuds		1	1	
46	3001427	Cable gland	Kabeldurchführung	Plaque passage câbles	Gennemføring		1	1	
47	107315043	Isolation	Isolierung	Embase isolation	Isolering		1	1	

Motor pump unit 5/Motorpumpeneinheit 5/Groupe moteur 5/Motorpumpeenhed 5

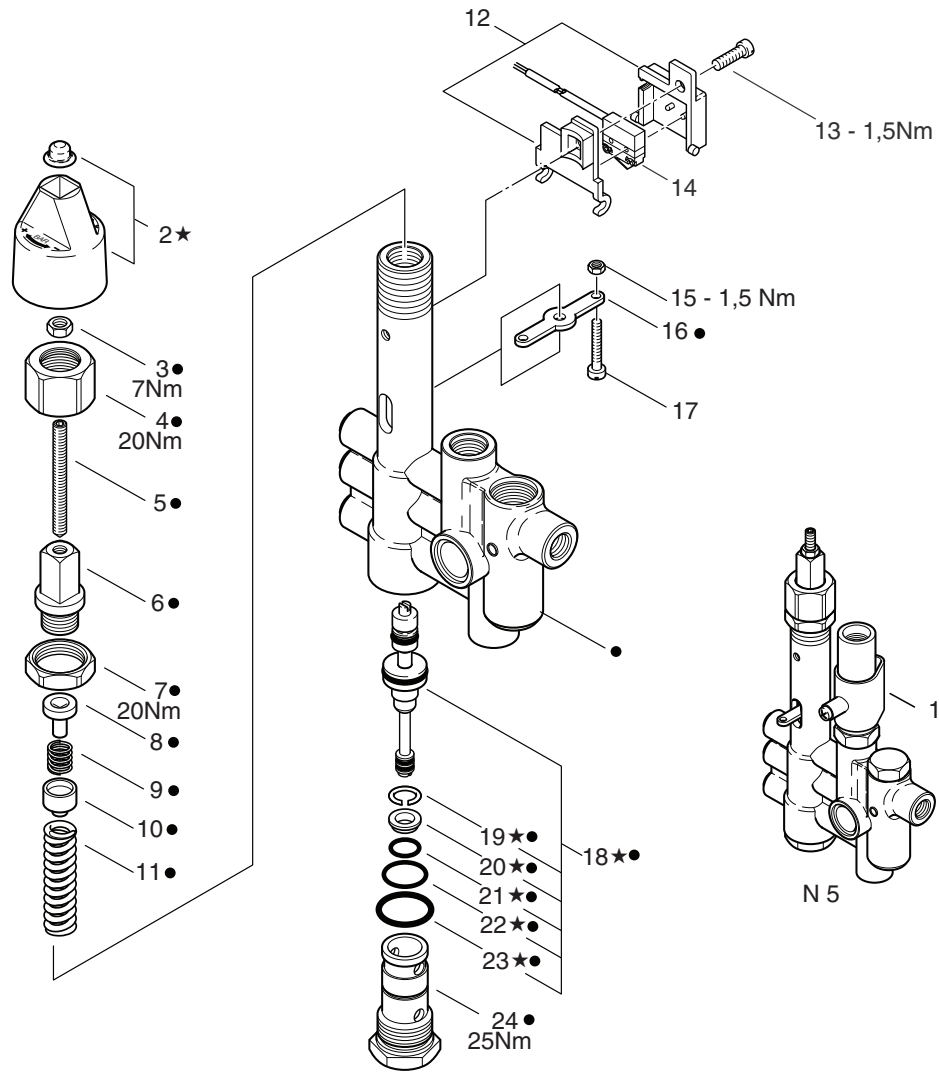

Pos.	No.	Description	Bezeichnung	Désignation	Betegnelse	Comment Bemerkung Bemærkning	Rec. Part	5-20D	5-20E
• 1	301000902	Unloader valve, 200bar	Regelsicherheitsblock	Bloc régulation/sécurité	Omløbsventil			1	1
★ 2	62397	Knob	Drehknopf	Molette de réglage	Drejeknap			1	1
• 3	3136	Nut M6	Mutter	Ecrou M6	Møtrik			1	1
• 4	62710	Nut M24x1,5x21	Überwurfmutter	Écrou M24x1,5x21	Omløber			1	1
• 5	62711	Threaded pin M6x60	Gewindestift	Tige filetée M6x60	Gevindstift			1	1
• 6	62712	Banjo bolt M16x1x9	Hohlschraube	Vis creuse M16x1x9	Banjobolt			1	1
• 7	62696	Nut M24x1,5x6	Mutter	Ecrou M24x1,5x6	Møtrik			1	1
• 8	62695	Spring support	Federauflage	Guide ressort	Fjederstyr			1	1
• 9	62713	Spring	Druckfeder	Ressort	Fjeder			1	1
• 10	62694	Spring support	Federauflage	Guide ressort	Fjederstyr			1	1
• 11	40972	Spring 3,5x10,5x54	Druckfeder	Ressort 3,5x10,5x54	Fjeder			1	1
12	62401	Bracket	Halter	Support microswitch	Beslag			1	1
13	3349	Screw M5x16	Schraube	Vis hexagonale M5x16	Skrue			1	1
14	301000731	Microswitch 250V 0,1A	Schalter	Microswitch 250V 0,1A	Microswitch		C	1	1
15	2759	Nut M8	Mutter	Ecrou M8	Møtrik			1	1
• 16	62717	Switch arm	Schaltfahne	Levier microswitch	Kontaktarm			1	1
17	5076	Screw M4x25	Schraube	Vis M4x25	Skrue			1	1
•★ 18	64314	Rep. set valve	Rep.satz Ventil	Kit réparation piston by-pass	Ventilsæt		B	1	1
•★ 19	909100001	Ring	Sprengring	Rondelle fendue	Ring			1	1
•★ 20	62708	Valve seat	Ventilsitz	Siège clapet	Ventilsæde			1	1
•★ 21	49461	O-ring 11x1,5	O-ring	Joint torique 11x1,5	O-ring			1	1
•★ 22	9523	O-ring 17x1,5	O-ring	Joint torique 17x1,5	O-ring			1	1
•★ 23	32091	O-ring 21,2	O-ring	Joint torique 21x2	O-ring			1	1
• 24	64301	Banjo bolt M24x1,5	Hohlschraube	Vis creuse M24x1,5	Banjobolt			1	1
★	63056	Rep.kit unloader valve	Rep.satz RS-Block	Kit réparation bloc régulation	Rep.kit, omløbsventil			1	1

Motor pump unit 5/Motorpumpeneinheit 5/Groupe moteur 5/Motorpumpeenhed 5

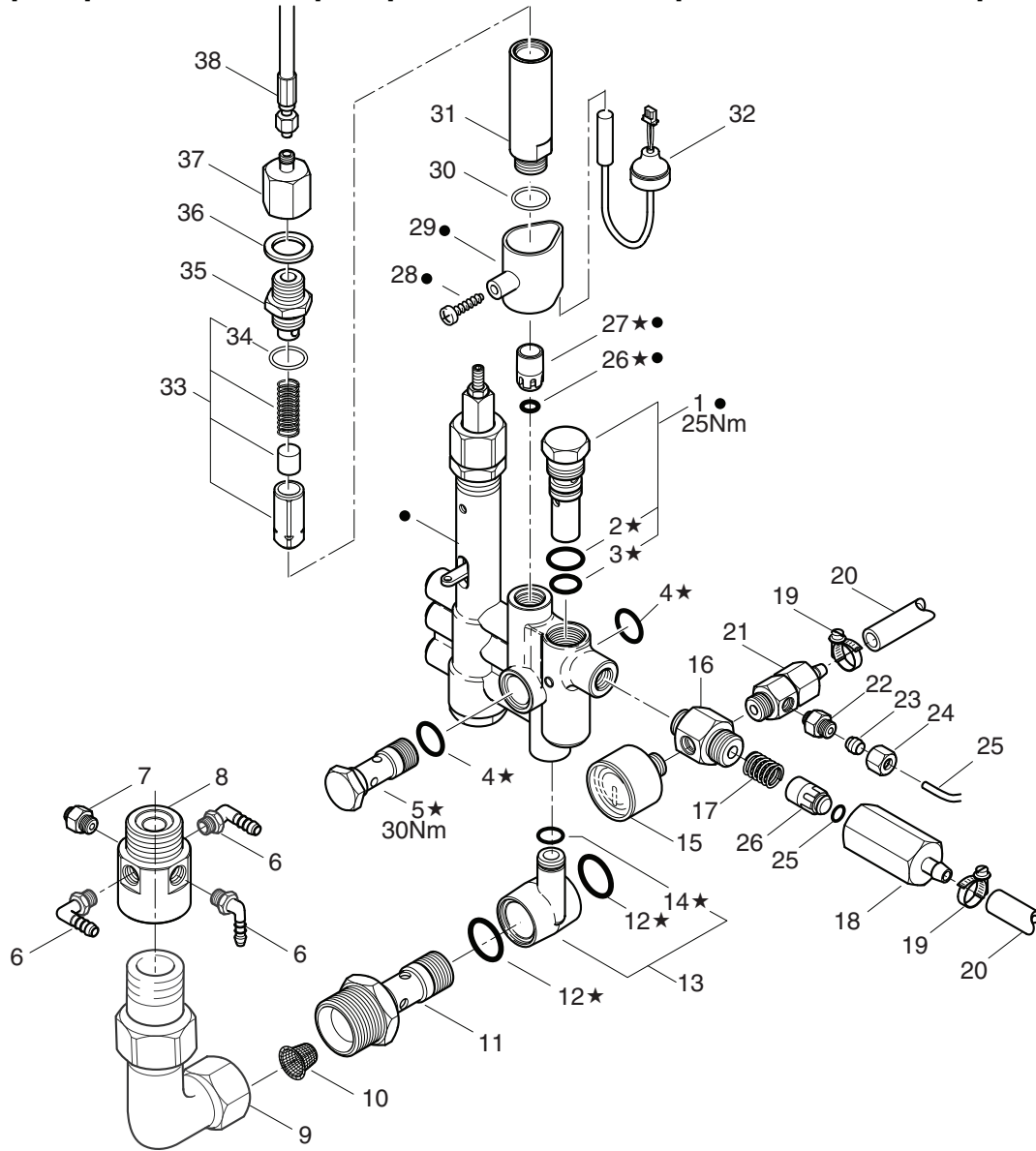

Pos.	No.	Description	Bezeichnung	Désignation	Betegnelse	Comment Bemerkung Remarque Bemærkning	Rec. Part	5-20D	5-20E
• 1	62730	Safety valve 200bar	Sicherheitsventil	Soupape sécurité 200 bars	Sikkerhedsventil			1	1
★ 2	16443	O-ring 17x2	O-ring	Joint torique 17x2	O-ring			1	1
★ 3	62706	O-ring 13x2	O-ring	Joint torique 13x2	O-ring			1	1
★ 4	16443	O-ring 17x2	O-ring	Joint torique 17x2	O-ring			2	2
★ 5	62697	Banjo bolt	Hohlschraube	Vis creuse	Banjobolt			1	1
6	101609375	Hose socket, elbow	Winkelschlauchstutzen	Raccord coudé	Slangestudsvinkel			3	3
7	1603422	Threaded connection	Verschraubung	Raccord fileté	Ligeforskrøning			1	1
8	107312024	Chemicals collection piece	Chemiesammelstück	Collecteur (détergent)	Kemihus			1	1
9	101609387	Union elbow	Winkelverbindung	Embout coudé	Vinkel union			1	1
10	62600	FILTER	Filter	Filtre	Filter			1	1
11	64302	Banjo bolt	Hohlschraube	Vis creuse	Banjobolt			1	1
12	24347	O-Ring 21x2,5	O-ring	Joint torique 21x2,5	O-ring			1	1
★ 13	63058	By-pass connection	Anschluss	Raccord en T	Tiilslutning			2	2
14	42768	O-ring 11,2x1,8	O-ring	Joint torique 11,2x1,8	O-ring			1	1
★ 15	301000246	Pressure gauge 0-300 bar	Manometer 0-300 bar	Manomètre 0-300 bar	Manometer 0-300 bar			1	1
16	107312021	Spacer	Zwischenstück	Raccord	Overgang			1	1
17	6182972	Spring f. non-return valve	Feder f. Rückschlagventil	Ressort clapet anti-retour	Fjeder for kontraventil			1	1
18	107312022	Housing for non-return valve	Gehäuse für Rückschlagventil	Carter clapet anti-retour	Hus for kontraventil			1	1
19	1807593	Hose clip	Schelle	Collier de serrage	Spændebånd			2	2
✘ 20	5206054	Hose	Schlauch	Tuyau	Slange			2	2
21	6220596	Venting valve, compl.	Entlüftungsventil, kompl.	Vis de purge, complète	Udluftningsventil, kompl.			1	1

Nifisk-ALTO - AUTO BOOSTER - Dec. 2004

✘ **ATTENTION!** - Lengths in metres - Please indicate required length when ordering!
✘ **ACHTUNG!** - Meterware - Bitte bei Bestellung gewünschte Länge angeben!

✘ **ATTENTION!** - Longueurs par mètre - Préciser la longueur à la commande!
✘ **BEMÆRK!** - Meterware - Vær venlig at oplyse længde ved bestilling!

Motor pump unit 5/Motorpumpeneinheit 5/Groupe moteur 5/Motorpumpeenhed 5

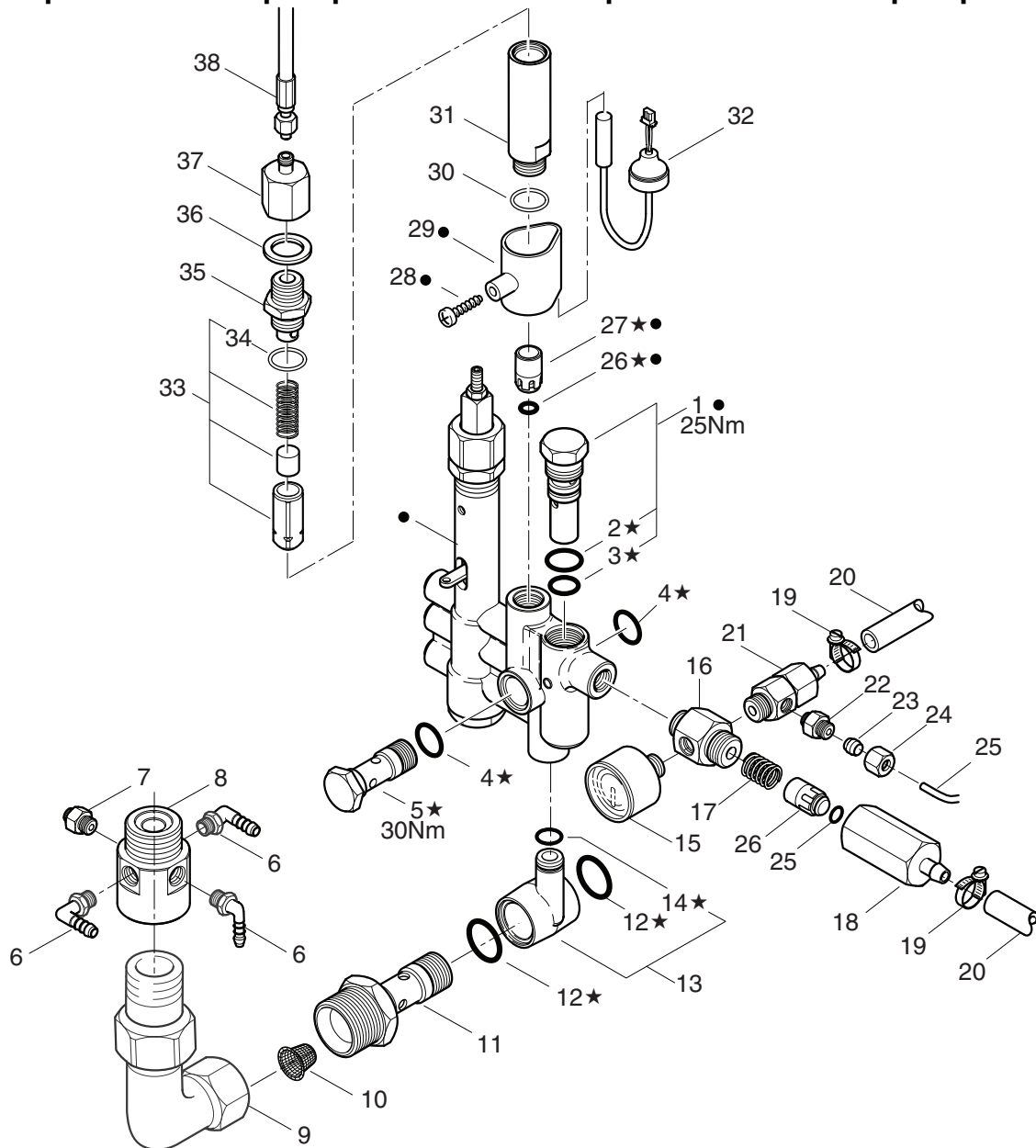

Pos.	No.	Description	Bezeichnung	Désignation	Betegnelse	Comment Bemerkung Remarque Bemærkning	Rec. Part	5-20D	5-20E
22	1603422	Threaded connection	Verschraubung	Raccord fileté	Forskruning			1	1
23	1603448	Cutting ring Ø4	Schneidring	Anneau Ø4	Skærerering			4	4
24	1603430	Union nut Ø4	Überwurfmutter	Écrou Ø4	Omløber			4	4
✘ 25	5203823	Copper tube	Kupferrohr	Tube cuivre Ø4	Kobberrør			2	2
26	56519	O-Ring 6,5x3	O-Ring	Joint torique 6,5x3	O-ring			2	2
27	301000905	Piston	Kolben	Piston	Stempel			2	2
28	1814614	Screw K50x18	Schraube	Vis K50x18	Skrue			1	1
29	62399	Bracket	Halter	Support	Holder			1	1
30	3000064	O-Ring	O-Ring	Joint torique	O-ring			1	1
31	107312023	Housing	Gehäuse	Carter	Hus			1	1
32	3830133	Reed contact	Rohrmagnetschalter	Interrupteur magnétique	Reedkontakt			1	1
33	101119411	Rep.kit piston	Rep.satz Steuerkolben	Kit réparation piston	Rep.sæt styrestempel			1	1
34	3000064	O-Ring	O-Ring	Joint torique	O-ring			1	1
35	107120609	Nipple 3/8"	Nippel	Mammelon 3/8"	Nippel			1	1
36	1801075	Packing ring Ø23,8xØ17,2	Dichtring	Rondelle joint Ø23,8xØ17,2	Tætningsskive			1	1
37	101609377	Threaded connection	Verschraubung	Raccord Ø6Lx3/8"	Forskruning			1	1
38	101405641	High pressure hose 8,2m	Hochdruckschlauch	Tuyau haute pression	Højtryksslange			1	1
★	63056	Kit, unloader valve	Rep.satz RS-Block	Kit réparation bloc régulation	Rep.sæt, omløbsventil			1	1
•	301000902	Unloader valve	Regelsicherheitsblock	Bloc régulation/sécurité	Omløbsventil			1	1

Nifisk-ALTO - AUTO BOOSTER - Dec. 2004

✘ **ATTENTION!** - Lengths in metres - Please indicate required length when ordering!
 ✘ **ACHTUNG!** - Meterware - Bitte bei Bestellung gewünschte Länge angeben!

✘ **ATTENTION!** - Longueurs par mètre - Préciser la longueur à la commande!
 ✘ **BEMÆRK!** - Meterware - Vær venlig at oplyse længde ved bestilling!

Motor pump unit 5/Motorpumpeneinheit 5/Groupe moteur 5/Motorpumpehed 5

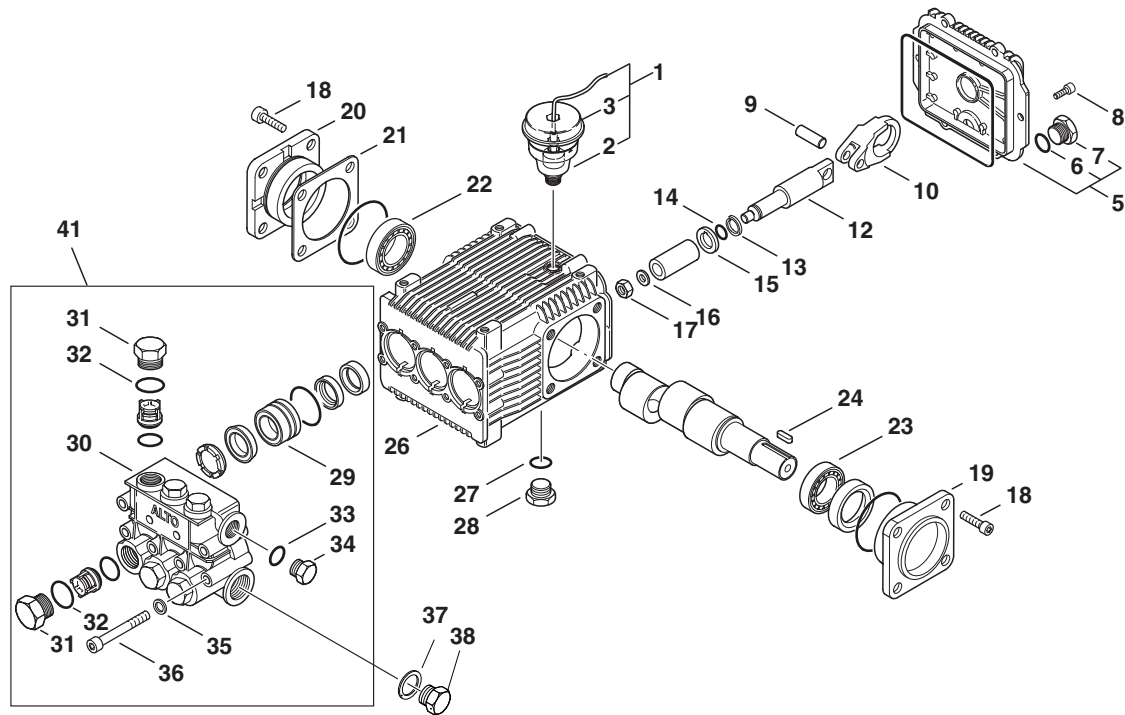

Pos.	No.	Description	Bezeichnung	Désignation	Betegnelse	Comment Bemerkung Bemærkning	Rec. Part	5-20D	5-20E
1	301000616	Pump oil container, compl.	Füllstandsanzeige	Jauge d'huile complète	Olieglass, kompl.			1	1
2	301000614	Container	Behälter	Réservoir huile Ø66,8x84	Beholder			1	1
3	301000615	Cover	Deckel	Couvercle flotteur	Låg	Ø70x15,5		1	1
5	301001158	Cover	Deckel	Couvercle	Låg			1	1
6	56554	O-ring	O-ring	Joint torique 14x1,78	O-ring			2	2
7	301001135	Plug	Stopfen	Bouchon carter G3/8"	Prop			1	1
8	909100158	Screw	Schraube	Vis M6x14	Skrue			6	6
9	301001138	Bar	Bolzen	Clavette	Aksel		B	3	3
10	301001168	Connecting rod	Pleuel Bronze	Bielle	Plejlstang		B	3	3
12	301001156	Piston rod	Kolbenstange	Tige de bielle	Stempelstang		B	3	3
13	49900	Supporting ring	Stützring	Bague	Støttering			3	3
14	3001740	O-ring	O-ring	Joint torique 7,66x1,78	O-ring			3	3
15	301001139	Distance spacer	Distanzscheibe	Entretoise	Afstandsskive			3	3
16	909100165	Packing ring Ø8x17	Dichtring	Joint Ø8x17	Pakning			3	3
17	909100167	Hexagon nut M8	Mutter M8	Ecrou hexagonal M8	Møtrik M8			3	3
18	2788	Screw M8x16	Schraube	Vis hexagonale M8x16	Skrue			8	8
19	301001167	Bearing cover, open	Lagerdeckel offen	Cache 80x80x8 ouvert	Lejedæksel åben			1	1
20	301001166	Bearing cover, closed	Lagerdeckel geschlossen	Cache 80x80x8 fermé	Lejedæksel lukket			1	1
21	301001140	Fit disc 80x80x0,05	Passscheibe	Entretoise 80x80x0,05	Pasningssskive		B		
21	301001141	Fit disc 80x80x0,10	Passscheibe	Entretoise 80x80x0,10	Pasningssskive		B		
21	301001142	Fit disc 80x80x0,20	Passscheibe	Entretoise 80x80x0,20	Pasningssskive		B		
21	301001143	Fit disc 80x80x0,25	Passscheibe	Entretoise 80x80x0,25	Pasningssskive		B		
22	909100163	Roller bearing	Rollenlager	Roulement	Rulleleje			1	1
23	909100162	Roller bearing	Rollenlager	Roulement	Rulleleje			1	1
24	19639	Key A8x7x25	Passfeder	Clavette Vilebrequin	Feder			1	1
26	301001157	Housing	Gehäuse	Carter de pompe	Hus			1	1
28	301001135	Plug	Stopfen	Bouchon carter G3/8"	Prop			1	1
29	301001154	Thrust collar	Kolbenführung 18mm	Guide de piston Ø18	Trykring		B	3	3
30	301001172	Cylinder head	Ventilblock Ms	Culasse	Topstykke			1	1
31	301001137	Plug	Stopfen	Bouchon M22	Prop			6	6
32	103004342	O-ring	O-ring	Joint torique 17,86x2,62	O-ring			6	6
33	1409	Packing ring	Dichtring	Joint Ø17x23	Pakningsring			1	1
34	301001134	Plug	Stopfen	Bouchon	Prop			1	1
35	909100168	Safety washer	Sicherungsscheibe	Circlip Ø8	Låseskive			8	8
36	1814597	Screw	Schraube	Vis M8x70	Skrue			8	8
37	5127	O-ring	O-ring	Joint torique	O-ring			1	1
38	301001136	Plug	Stopfen	Bouchon G1/2"	Prop			1	1
41	301001170	Cylinder head compl.	Ventilblock kpl.	Culasse complète piston	Topstykke, kompl.	18mm		1	1

Motor pump unit 5/Motorpumpeneinheit 5/Groupe moteur 5/Motorpumpeenhed 5

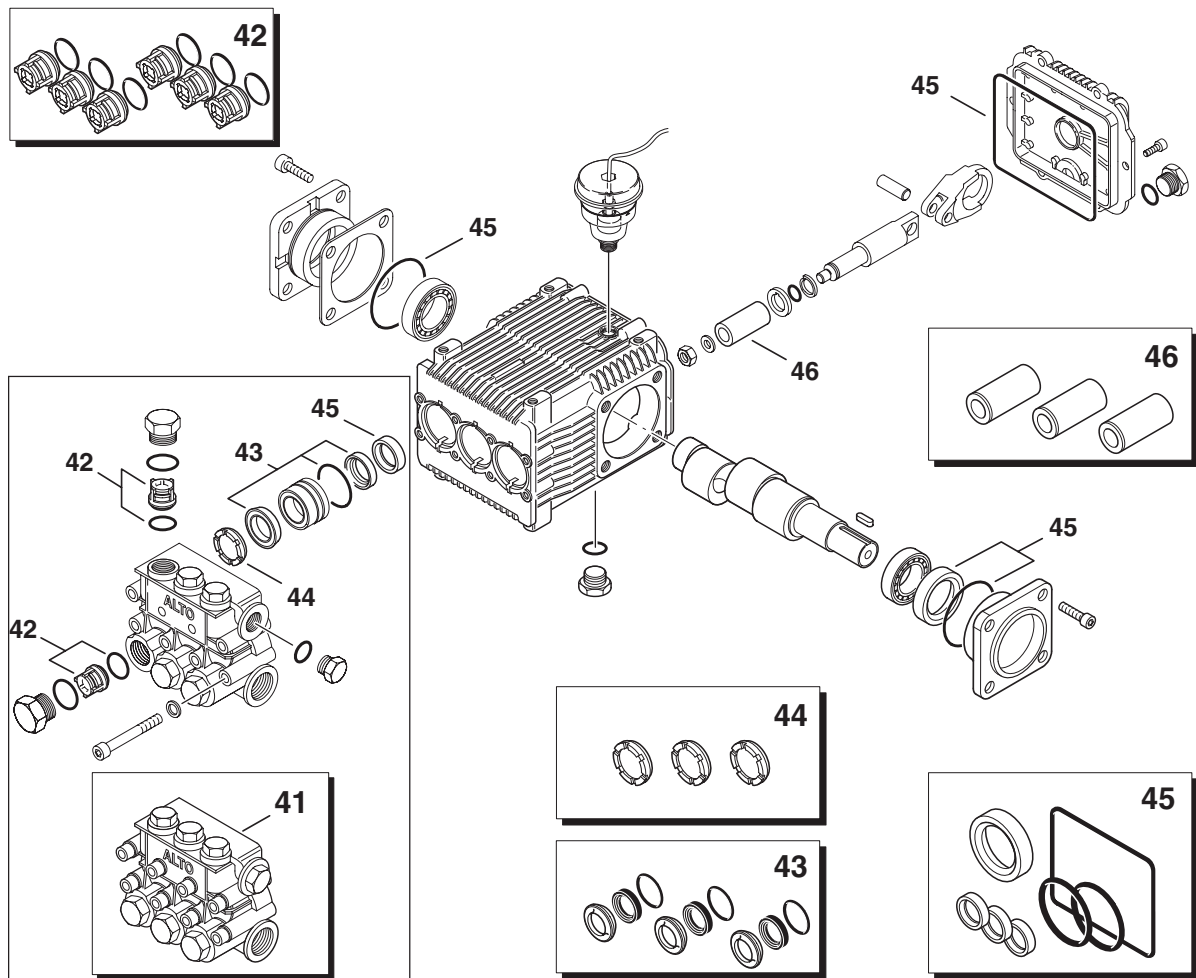

Pos.	No.	Description	Bezeichnung	Désignation	Betegnelse	Comment Bemerkung Remarque Bemærkning	Rec. Part	5-20D	5-20E
41	301001170	Cylinder head compl.	Ventilblock kpl.	Culasse complète piston 18mm	Topstykke, kompl.			1	1
42	301001153	Valve kit	Ventile Set	Jeu 6 soupapes pour pompe	Ventilsæt		A	1	1
43	301001148	Piston sealing kit	Kolbendichtung Set	Kit joint piston Ø18	Stempelpakningssæt		A	1	1
44	301001151	Support ring	Stützring Set	Kit bague Ø18	Støtteringssæt			1	1
45	301001150	Oil sealing kit	Öldichtung Set	Kit joint carter pompe	Oliepakningssæt		C	1	1
46	301001146	Piston kit	Keramikkolben Set	Kit piston céramique Ø18	Stempelsæt		C	1	1
-	107312020	Pump	Pumpe	Pompe	Pumpe		C	1	1

Motor pump unit 5/Motorpumpeneinheit 5/Groupe moteur 5/Motorpumpeenhed 5

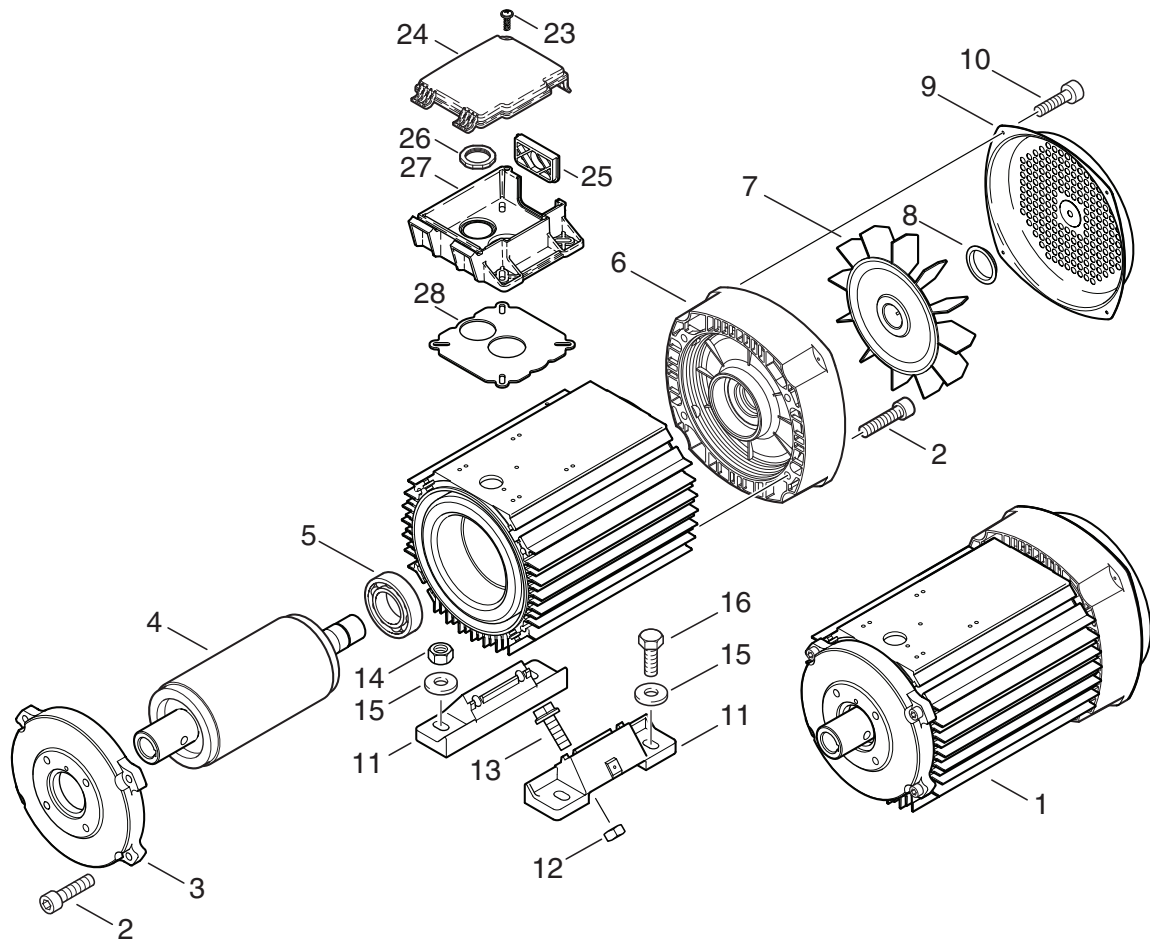

Pos.	No.	Description	Bezeichnung	Désignation	Betegnelse	Comment Bemerkung Bemærkning	Rec. Part	5-20D	5-20E
1	301000751	Motor 4kW 230/400 V	Motor	Moteur 4kW 230/400 V	Motor		C	1	1
2	6863	Screw M8x35	Schraube	Vis M8x35	Skrue			8	8
3	301001119	Motor flange	Motorflansch	Flasque moteur	Motorflange			1	1
4	301001122	Rotor	Rotor	Rotor moteur 4,5kW	Rotor			1	1
5	5905	Roller bearing	Wälzlager	Roulement	Rulleleje			1	1
6	301001113	Bearing cover - rear	Lagerdeckel hinten	Flasque arrière	Lejedæksel, bag			1	1
7	301001117	Fan	Lüfterrad	Ventilateur	Ventilator			1	1
8	301001112	Fastening ring	Klemmring	Circlip ventilateur	Klemring			1	1
9	301001115	Fan housing	Lüfterhaube	Cache de protection	Ventilatorhus			1	1
10	8822	Screw	Schraube	Vis 3,5x9,5	Skrue			4	4
11	301001126	Motor foot 45mm	Motorfuß	Support moteur	Motorfod			1	2
12	6052	Nut M8	Sechskantmutter	Ecrou M8	Møtrik			1	1
13	27372	Bolt M8x20	Verbusschraube	Vis M8x20	Skrue			1	1
14	61467	Nut M8	Mutter	Ecrou hexagonal M8	Møtrik			4	4
15	2793	Washer	Scheibe	Rondelle 8,4x2	Skive			4	4
16	2750	Bolt M8x25	Schraube	Vis hexagonale M8x25	Skrue			4	4
23	10028	Screw	Schraube	Vis	Skrue			4	4
24	301000782	Cover f. connection box	Deckel f. Schaltkasten	Couvercle boîtier électrique	Låg f. klemkasse			1	1
25	17106	Support	Einsatz	Support	Indsats			1	1
26	20862	Nut	Mutter	Ecrou	Møtrik			1	1
27	301000781	Connection box	Schaltkasten	Boîtier électrique	Klemkasse			1	1
28	301000845	Gasket	Dichtung	Joint	Pakning			1	1

Wash boom / Schwinkarm / Bras de lavage / Galge

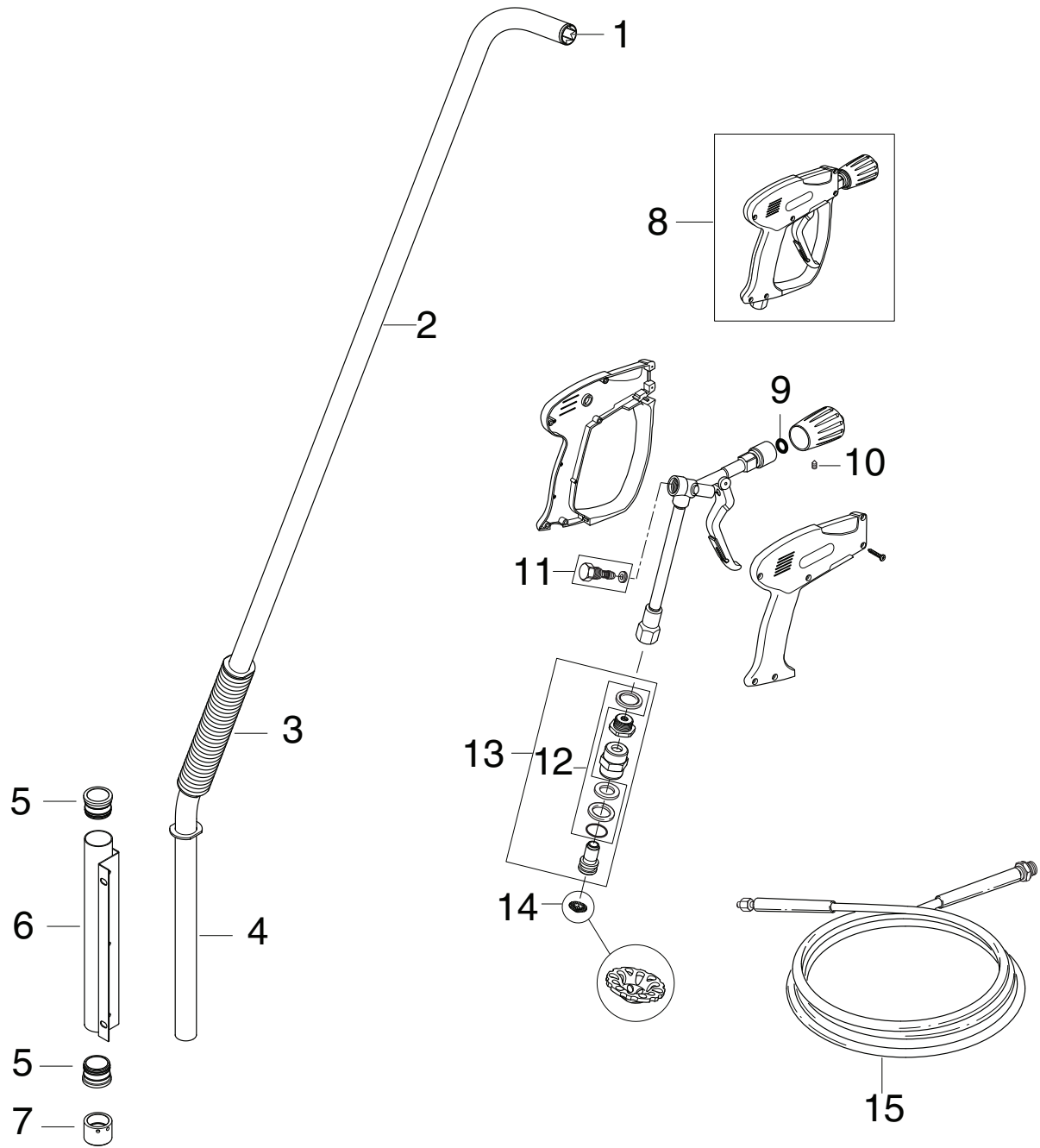

Pos.	No.	Description	Bezeichnung	Désignation	Betegnelse	Comment Bemerkung Remarque Bemærkning	Rec. Part	5-20D	5-20E12	7-20E6
1	107313212	Bushing	Durchführung	Traversée	Gennemføring			1	1	1
2	107313259	Wash boom	Schwinkarm	Bras de lavage	Galgebom			1	1	1
3	102602526	Spring	Feder	Ressort	Fjeder			1	1	1
4	107313258	Wash boom foot	Schwinkarmfuß	Pied de bras	Galgestamme			1	1	1
5	107313211	Driving sleeve	Wellenlagerbüchse	manchon d'entraînement	Lejebøsning			2	2	2
6	107313254	Bracket	Halter	Support	Beslag			1	1	1
7	107313261	Circlip	Schließring	Circlip	Låsering			1	1	1
8	106402243	Weeping winter gun	Frostsichere Pistole	Poignée gâchette d'hiver	Vinterspulehåndtag			1	1	1
9	103004366	O-ring	O-Ring	Joint torique	O-ring			1	1	1
10	101814752	Pointed screw	Reitstockschraube	Vis pivot	Pinolskrue M6x6			1	1	1
11	106408048	Kit, f. weeping winter gun	Satz, f. Frostsichere Pistole	Kit, poignée gâchette d'hiver	Sæt, for vinterhåndtag			1	1	1
12	101119485	Kit, seal for swivel joint	Satz, Dichtung f. Gelenk	Kit, joint pour tournate	Sæt, tætning f. drejeled			1	1	1
13	101119484	Kit, swivel joint	Satz, Gelenk	Kit, tournante	Sæt, drejeled			1	1	1
14	101609367	Filter	Filter	Filtre	Filter			1	1	1
15	101405641	Hose steelarm L=8,2m	Schlauch stahlarmierte	Tuyau renforcement 8,2m	Stålarmeret slange			1	1	1